

ORIGINAL

Copy

The New Illustrated Building Code

by

Yoshiyuki Mizukoshi

(Former Policy Planning Official,
Minister's Secretariat, The Ministry
of Construction)

(Former Construction Specialist,
Building Guidance Section, Housing
Bureau, The Ministry of Construction)

published by

Shinnippon Hōki

③ APPENDIX : For Foreign Readers

TITLE OF THE BOOK : ILLUSTRATED BUILDING LAWS
(1978 Edition)

AUTHOR : Yoshiyuki Mizukoshi
Director, and Manager for Technical Assessment & Evaluation, the Building Center of Japan, Foundation.

- 1951 ; Qualified as a Senior Government Official of a university graduate.
 - 1952 ; Received architectural and engineering degrees from Waseda University, Tokyo, Japan.
 - " ; Technical Officer, Housing Bureau, the Ministry of Construction.
 - 1960-61 ; Expert, Housing and Home Finance Agency (present HUD), the U.S. Government.
 - 1962 ; Technical Officer, Land Development Division, Ministry of Construction.
 - 1963-65 ; Instructor, School of Engineering, Tokyo Metropolitan University, concurrently.
 - 1965 ; Director, Department of Building and Housing, Prefectural Government of Shiga.
 - 1967 ; Chief Engineer, Building Regulation and Guidance Division, the Ministry of Construction.
 - 1972 ; Senior Policy Planning Officer, Secretariate to the Minister of Construction.
 - 1973-present ; Lecturer, Nihon University, & Tokyo Science University, concurrently.
 - 1974-present ; the present post.
- PUBLISHER: Shin-Nihon Hoki-Shuppan Co., Ltd.
6-2, Ichigaya, Sadohara-cho, Shinjuku-ku, Tokyo 162, Japan
Tel. 03-269-2220

SPECIAL FEATURES OF THIS BOOK:

In Japan, only a fundamental and overall law concerning construction and maintenance of building, is the Building Standard Law, which is a nation-wide and mandatory regulation, and which covers all buildings, sites, equipments and the concerned.

The orders based on the Law, consisting of hundreds articles, are being enforced for going details. Those of orders are the Enforcement Cabinet Order (Shiko-Rei) and the Minister's Orders (Shiko-Kisoku and Kensetsu-Sho-Kokuji).

In this book, a numbers of provisions concerning the same matter and purpose are gathered into a bundle, and collectively explained with tables and diagrams.

Therefore, it is not necessary for those who want study the building laws, to spare the time in checking and searching the many scattered provisions in the Law and the orders.

This is the point highly appreciated by the people concerned.

Some laws are being enforced for specific purpose, relating to land subdivision, public facilities, fire-fightings, etc.

Those regulations are also explained in this book, for the convenience of the readers.

For the convenience of foreign readers who take interest in Japanese building regulation, a table of contents written in English, is attached herewith. If there is any inquiry, the author will be glad to answer. Write to the B.C.J., 1-14-16, Harumi, Chuo-ku, Tokyo 104, Japan.

TABLE OF CONTENT

CHAPTER I BEFORE STUDYING BUILDING LAWS

SECTION I HISTORY OF BUILDING REGULATIONS

- 1: The Background and the Raison D'être, in the World
- 2: History of Building Regulation, in Japan
- 3: Origin and Development of "Building Standard Law"

SECTION II OUTLINE OF LAWS AND ORDERS RELATED TO BUILDING

- 1: The Relations to Site, Construction and Equipment of Building
- 2: The Relations to Specific Use of Building
- 3: The Relations to Business Permit
- 4: The Relations to Handling, Deposit and Processing of Dangerous Materials
- 5: The Relations to Building Equipment
- 6: The Relations to Urban Planning, Land Use, Environment Protection, Public Nuisance, etc.
- 7: The Relations to Promotion and Public Assistance of Building and Urban Development
- 8: The Relations to Civil Rights and Obligations, such as the Civil Law

SECTION III BASIC KNOWLEDGE REQUIRED TO MASTER BUILDING LAWS

- 1: Taxonomy and Priority of Laws, in General
- 2: Forms and Types of Laws, in General
- 3: Terms and Definitions in Laws, in General

SECTION IV CHARACTERISTICS AND JURISDICTION OF THE BUILDING STANDARD LAW

- 1: Characteristics
- 2: Machinery and Jurisdiction
- 3: Special Exceptions of the Technical Standards

CHAPTER II TECHNICAL STANDARDS TO SECURE SAFETY OF BUILDING (STRUCTURAL SAFETY, HYGIENE AND FIRE PREVENTION IN BUILDING STANDARD LAW)

SECTION I ENSURING SAFETY OF BUILDING

- 1: What is Safety in Building?
- 2: What is Safety in Case of "Special Building" (Public Building)?
- 3: Forms and Types of Standards
- 4: How an Architect and/or an Engineer to be facing to a Standard

SECTION II BUILDING AND ITS SITE

- 1: Sanitary Condition and Safety of Building Site
- 2: Disaster Prospected District and Land Development Controlled District

SECTION III CONSTRUCTION AND STRUCTURAL ANALYSIS

- 1: Fundamental Principles
- 2: Structural Elements
- 3: Construction Methods
 - 1) Wooden Construction
 - 2) Masonry Construction
 - 3) Reinforced Concrete-Block Construction
 - 4) Steel Frame Construction
 - 5) Reinforced Concrete Construction
 - 6) Steel Frame and Reinforced Concrete Construction
 - 7) Simple Concrete Construction
- 4: Structural Analysis
 - 1) Principles of Calculation
 - 2) Loads and External Forces
 - 3) Allowable Stress of Materials
 - 4) Limit Stress of Materials

SECTION IV FIRE PREVENTION AND EMERGENCY FACILITIES

- 1: Philosophy of Planning of Fire Prevention and Emergency Escape
- 2: Structural Restriction and Fire Partition
- 3: Escape Facilities
- 4: Interior Finish Restriction
- 5: Smoke Exhausting Devices
- 6: Emergency Lighting Devices

- 7: Emergency Fire Force Entrance
- 8: Emergency Elevator
- 9: Central Operation Room (Emergency Control Center)
- 10: Lightning Arrester
- 11: Underground Building and its Passage
- 12: Miscellaneous

SECTION V CONSTRUCTION AND FACILITIES FOR INDOOR ENVIRONMENTAL AND SANITARY CONDITIONS (HYGIENE)

- 1: Sun-lighting, Sky-lighting and Ventilation of "Kyo-shitsu" (a space and/or room for human habitation, office, work, assembly, entertainment and the like)
- 2: Height of Ceiling and Floor, and Moisture Prevention of "Kyo-shitsu"
- 3: Ventilation of a Space and/or Room where Open Fire Used
- 4: Sound Insulation of Multiple Dwelling and Row Houses
- 5: General Standard for Stairs
- 6: Air Conditioning and Ventilating Equipment
- 7: Toilet, Septic Tank and Community Plant
- 8: Water Supply Equipment and Sewerage Equipment
- 9: Cooling Tower and Equipment
- 10: Elevator, Escalator, etc.
- 11: Standards for the other Equipments and Facilities

SECTION VI OTHERS

- 1: Chimney, Pole, Tower, Sign, Silo, etc.
- 2: Entertainment Facilities such as Observation Elevator, etc. and Amusement Facilities such as Coaster, Merry-goround, Airplane Tower, etc.
- 3: Accident and Danger Prevention at Construction Site
- 4: Approval of Fire-proof Material, Fire-resistive Construction, etc.
- 5: Registration of Element and Construction Method
- 6: Compulsory Usage of Materials, Elements, Equipments, etc., confirmed with JIS or JAS

CHAPTER III STANDARD FOR URBAN PLANNING AND DEVELOPMENT
(REQUIRED STREET, USE ZONES, BUILDING'S STAIRBULK COVERAGE, FIRE ZONES, ETC., IN BUILDING STANDARD LAW)

SECTION I STANDARD FOR URBAN BUILDING

- 1: Urban Planning and Building
- 2: City Planning Law and Building Standard Law
- 3: Laws relating to Urban Planning, other than the above

SECTION II BUILDING REGULATION DUE TO STREET

- 1: Building and Street
- 2: Definition of Street
- 3: Relation required, between Building Site and Street

- 4: Building Restriction on Street
- 5: Wall Limit Line

SECTION III USE ZONES

- 1: Purpose of Use Zones
- 2: Classification of Use Zones and Building Restriction
- 3: Building Permit for Exception
- 4: Special Use Districts
- 5: Location of Specified Building
- 6: Miscellaneous

SECTION IV BUILDING AREA, SITE AREA AND HEIGHT

- 1: Ratio of Total (Gross) Floor Area to Site Area (Bulk Ratio)
- 2: Ratio of Building Coverage to Site Area (Coverage Ratio)
- 3: Maximum Height and Wall Set-back, in No. 1 Exclusive Residential Zone
- 4: Height Restriction due to Width of Street
- 5: Height Restriction on Site Boundary Line
- 6: Height Restriction on Site Boundary Line of North Side, in No. 1 & 2 Exclusive Residential Zones
- 7: Height Restriction, based on Sun-shadow Control
- 8: Miscellaneous

SECTION V FIRE ZONES

- 1: Purpose of Fire Zoning
- 2: Structural Restriction in Fire Zone and Quasi-Fire Zone
- 3: Miscellaneous

SECTION VI DISTRICT-PLAN, ETC

- 1: Needs for District-Plan, etc.
- 2: District-Plan and Development Program
- 3: Development-Plan along Major Highways

SECTION VII OTHERS

- 1: A Group of Buildings (Planned Unit Development)
- 2: Building Agreement
- 3: Scenic District
- 4: Enforcement for Building and the Site, on different Areas-Zones-Districts, designated
- 5: Enforcement for the Specific Structures, other than Building

CHAPTER IV A LIFE OF A BUILDING—PROCEDURES AND REGULATIONS, CONCERNED

SECTION I BEFORE CONSTRUCTION

- 1: Building to be designed by a Registered Architect
- 2: Confirmation Application, to Building Super-intendent

- 3: Permit Application, for Exception to Local Public Body (Governor or the Specified Mayor)
- 4: Miscellaneous

SECTION II DURING CONSTRUCTION

- 1: Construction Start Report
- 2: Sign of Confirmation at Site
- 3: Accident and Danger Prevention at Site
- 4: Restriction of Partial Occupancy of "Special Building" as defined, under Construction
- 5: Submission of Safety Securing Program of Building under Construction

SECTION III COMPLETION OF CONSTRUCTION AND START OF OCCUPANCY

- 1: Completion Report
- 2: Certificate of Official Inspection, and Prohibition of Occupancy of "Special Building" before the Inspection

SECTION IV MAINTENANCE OF BUILDING—PROCEDURES AND RESTRICTIONS

- 1: Extension, Removal, Repair and Remodeling
- 2: Change of Occupancy of Building
- 3: Periodical Inspection and Report

SECTION V DEMOLITION

- 1: Demolition Report

SECTION VI MISCELLANEOUS

APPENDIX

- 1: Definition of Terms
- 2: Laws and Orders

Building Standard Law (Kenchiku Kijun Ho) **345-387**
 Building Standard Law Enforcement Order (Kenchiku Kijun Ho Shiko-rei) **388-479**
 Building Standard Law Cabinet Order (Kenchiku Kijun Ho Shiko-kisoku) **180-488**
 List of Minister's Orders **515-519**
 Architect Law (Kenchiku-shi Ho) **5-18 to 522**
 City Planning Law (Toshi Keikaku Ho) **528-550**

End

著者略歴

昭和27年 早稲田大学理工学部建築学科卒業
 同 年 建設省入省 (建築指導課)
 その 後 住宅建設課係長、宅地課係長
 建設省住宅局建築指導課建設専門官
 建設省大臣官房財政課企画官
 同 年 建設省大臣官房第一理事 (課長担当)
 昭和49年 日本大学 (生産工学部) 及び東京理科大学講師
 現在に至る

新図解建築法規

昭和46年7月20日 初 版発行
 昭和56年3月27日 第13版発行

定 価 1,600円

不 許 製

著 者 水 越 義 幸
 発行兼 河 合 洋 次 郎
 印刷者

発行者 新日本法規出版株式会社

本社 東京都新宿区市谷砂土原町2-6
 支社 大阪・名古屋・福岡・仙台・札幌・広島
 高松

印刷 新日本法規出版株式会社印刷部

Words of Recommendation

Whether in Japan or foreign countries, we often hear from Japanese as well as foreign building engineers the criticism that the building code is hard to understand.

As long as engineers do the actual building, needless to say, the building code must be easily understandable to them. As a practical problem, however, the code itself is destined to be made within a certain existing lawmaking procedure and law system. Moreover, the building code, as a technical code, needs to be precise. Practically speaking, it would be a task of extreme difficulty to eliminate all difficulties in understanding the building code.

Many people have suggested describing the code in diagrams and charts as much as possible. When we give much thought to this matter, however, even the existing form of the code can satisfy this necessity in practice if we have a practical manual to supplement it. I have heard that there are many such examples in foreign countries.

Based on this idea, Construction Specialist Yoshiyuki Mizukoshi, who participated in drafting the revised Building Standards Law, has written this laborious book based on his many year experience in administration of the building code. In this book he is not playing with the words of lawmakers. Instead, he covers all necessary practical matters. For this reason, I consider the book worth recommending for broad general readers in building business.

Originally, the efforts to make the building code widely known were one of the important tasks of our Japan Building Center's information activities. In this sense too, I expect this book can be of great social significance and a great contribution to the building business.

June, 1971

Osamu Hieda

Chairman of the Board of Directors
Japan Building Center

Words of Recommendation

It is needless to say that not only more than half of land usage in cities is for the purpose of constructing houses and buildings but also that buildings have an important role in human life.

Urban planning and the building of towns are both nothing more than a question of how to construct safe houses and buildings in harmony with an environment. In terms of economic activities, we know the construction industry's importance from the fact that it occupies the second highest place in the gross national product of every industrialized nation.

Although the building code has always been a direct guide to buildings and building activities, building engineers have tended to think the building code was difficult to understand and unapproachable. This tendency is regrettable.

One of the characteristics of a technical code is an emphasis placed on precision and exactness. Consequently, the descriptions contained in the building code are not simple summaries. Also, in legislation, as a rule, visual expression is scarcely used. These conditions are the same in foreign countries.

However, in America and European countries private information sources called Code Information or Code Analysis are available. There are no such examples in Japan. Often this kind of manual is mistakenly cited as an example of how easy American and European laws are to understand. We have been aware of the practical necessity of this kind of manual in Japan too.

This book was planned from this point of view. As an official who has been administering the building code since the Building Standards Law of the pioneer days up to the present, in particular as an official who participated in writing the completely revised version of 1970 as the chief of the concerned section in the Ministry of Construction, I believe this book is very appropriate for a wide spectrum of readers ranging from students in technical high schools to building engineers dealing with actual construction. The latter will want to always keep this book in their hands and improve their understanding of the building code.

The author of this book, Construction Specialist Yoshiyuki Mizukoshi is a twenty-year veteran in this area. His experiences include a career as the chief of the relevant section in a local government, which is the front line for administration of the building code. It is fair to say that he knows well both the inside and outside of building code administration. In addition the publisher, the Shinnippon Hōki Kabushiki Kaisha, enjoys the highest reputation in the code publishing business. It has published Construction-Related JIS Summary and Handbook for Fire-Resistant and Fire-Preventive Structures and Materials and has been making a great contribution to the wider understanding of building code administration since its publication of Collected Building Codes in 1954.

Finally, I would also like to recommend this book to general readers outside the building business as the most appropriate book for understanding the building code.

June, 1971

Yoshihiro Maekawa

(Manager of Construction,
Kanagawa Prefecture)
(Former Chief, Building Guidance
Section, Housing Bureau, The
Ministry of Construction)

Introduction

We often hear criticism, (maybe I should instead say accusations), that the building code is hard to understand.

From my own experience, I have heard many building engineers say so in the United States and Europe. I have no intention of being dogmatic, but it is also true that I am inclined to agree with the British building engineer who said, "Since we are entrusted with building houses and buildings by citizens, it is our duty as professionals to be thoroughly acquainted with laws and regulations concerning buildings."

Actually, there are not a few cases in the United States and European countries where a professional organization compiles a handbook or guidebook, and if you follow it, it is legally accepted. In particular, in the United States each city and town has an independent law or regulation, and the building codes and zoning codes are more or less different in each city. Consequently, the publication of manuals is widespread. (Note: The oft mentioned Uniform Building Code, the Basic Building Code, and the fire prevention code issued by the fire insurance association are not laws but reference materials for the laws and regulations of local governments. This aspect is misunderstood in Japan.)

Japan has adapted the nationwide uniform system of the Building Standards Law. This system has advantages in terms of the above-mentioned point and in the areas of manufacturing and distribution. On the other hand, it contains many various and

complicated elements in order to maintain universality. Consequently, it has the disadvantage of making the law hard to understand. In addition, it is undeniable that, generally speaking, Japanese legislative rules themselves contribute to the difficulty of understanding laws. (One example is a rule that prohibits the use of figures and charts in laws and regulations as long as the situation can be described in words.)

In writing this book, I thought about these conditions and decided to gather all related items in one section regardless of legal distinctions (laws, government ordinances, Ministerial ordinances, notifications, etc). In addition I used many figures and charts. I did so to enable a wide spectrum of readers ranging from technical high school students to practicing building engineers to keep this book in their hands constantly and to improve their understanding of the building code.

What I especially want to mention here is this. The Illustrated Building Code written by Mr. Shunji Miyake and Mr. Terumi Kitabatake went out of print when the Building Standards Law was completely revised in 1970. This book has been newly planned as a replacement.

By mentioning this here, I would like to express my appreciation and respect to them once again.

My special thanks extend to Mr. Yoshihiro Maekawa, the then Chief, Building Guidance Section, Housing Bureau, the Ministry of Construction, for his encouragement.

Finally, it would be my great pleasure if this book could be an aide for not only those engaged in the construction business

but also for general readers seeking to understand the building code.

June, 1971

Yoshiyuki Mizukoshi

For foreign readers:

See appendix 3, attached at the end of this book, please.

P.S.

This book has been repeatedly reprinted and this is the thirteenth print. In this print we revised mainly the sections on district planning and wayside environment improvement planning in the zoning code and the earthquake-resistance calculation in the building code.

Since a part of the Construction Ministerial Notification had not been announced by the time of this revision, we made every effort to include as much of the necessary information as possible. But there still may be incomplete explanations in this book. We apologize and ask for your understanding.

January, 1981

The Editor

NOTE

- (1) This book was written and edited for those studying architecture and those engaged in the construction business. We used figures and charts as much as possible to elucidate so that the difficult building code becomes more familiar and easily understandable at a glance. Furthermore, we added simple explanations. In doing so we hope readers will be able to acquire a correct understanding more easily.
- (2) This book is based on the new Building Standards Law and explains in detail both the theory and practice of the system.
- (3) In explanation the section of the law referred to is indicated in brackets. In other words, [Law, Article 97-2, Item 2. Item 4_7] means the Building Standards Law, Article 97-2, Items 2 and 4.
- (4) In the explanation the following abbreviations are used. Ministerial Notifications are indicated as "19__ Ministerial Notification No. __." We do not give the titles. For other laws and ordinances, we indicate the actual titles of laws and ordinances.
- law --- Building Standards Law
 ordinance --- Building Standards Law Enforcement Ordinance
 regulation --- Building Standards Law Enforcement Regulation
 architect law --- Registered Architects Law
 urban law --- Urban Planning Law
- (5) As appendices at the back of the book we included major laws and ordinances for practical reference as well as a glossary

arranged by Japanese alphabetical order.

(page 1)

NEW ILLUSTRATED BUILDING CODE

Chapter 1. Before Learning the Building Code

ACTION I History of the Building Code

1. (1) Early Days of the Building Code and Its Significance

When we look around us, we find buildings wherever men are living. Whether they are residential houses in which we take our rest and reproduce our energy for tomorrow, or offices, stores, and factories where we conduct business and work, or entertainment facilities where we engage in recreation activities, the social activities of our daily lives almost always take place in a building. In terms of the physical aspect it can be said that a building itself has a life in society.

The conditions and order necessary to construct and maintain buildings are called building codes. Why do we need a building code? A man building a house on his own land may say, "Let me do it freely!"

Or, the manager of a store may say, "If a wall falls apart in my store and harms my customer, I will compensate him by myself."

The question of why we need a building code can easily be answered if we think hypothetically. What would happen to buildings, streets, and cities if we did not have a building code?

If people build their houses on their land without giving a thought to sunshine, lighting, and ventilation, and without

considering drainage systems for rainwater, fire protective measures, and earthquake resistance measures, what sort of consequences would ensue in the end? Even today with the building code, we find problems of deteriorating environmental conditions and poor disaster-tolerance capabilities in cities. It is easy to imagine that the situation would be incomparably worse than the present without the building code.

(page 2) Of course, no one wants to have a building that has poor sanitary conditions and lacks structural durability. We regret to say, however, that both our past and present show us our logical desire for safety, sanitation, and comfortability being continuously overpowered by economic conditions and the conditions of cities.

As men shifted from a nomadic to an agricultural life, men began domiciling themselves in one place and forming a community. Then the necessity of having rules for building arose as one of rules of community life.

In 2000 BC Hammurabi, the founder of the Babylonian Empire, established a written law called the Code of Hammurabi. In it the relationship between the building engineer and client was clearly legislated. To a client, it imposed that obligation to pay a reward to building engineers (the designer and the builder). On the other hand, it provided that, "In case a client or a member of his family is killed because of a defect to the building (collapse, etc.), the building engineer or a member of his family should be beheaded." Furthermore, it provided that when a slave of a client was killed, the building engineer must replace

the deceased with another slave. It is made clear that a building engineer has an obligation to secure the safety of a building.

In ancient Rome a building code also existed. According to records of about 450 BC, one of the customary laws put into writing said that, "Buildings must have an ambitus of five feet between each other." In other words, it provided that a building must be at least 2.5 feet inside the boundary with an adjoining lot. A similar rule can be found in the present Japanese Civil Law Act No. 234, which determines the relation of two houses adjacent to each other: "Except where special custom exists, when building a house, the house must be at least 50 cm inside the boundary of the lot." This rule is also based on the same thought as the backdown restriction from the boundary of a lot located within the Class 1 Residential District established in the Building Standard Law. This rule can be considered the origin of the setback regulation in the building code.

However, when the population of Rome increased, people tended to minimize the 5 feet of space between two houses. There appeared the custom of building houses connected to each other and divided by common walls. They started building a kind of common house called insula. Then, the height of buildings gradually became taller in order to utilize land more efficiently. They even built nine-story apartments of combustible materials. As a result, the problems of shade and disaster prevention became a social issue. (page 3) Therefore, limits on the height of buildings and strengthening the connection between beam and pillar were provided in the building laws. Emperor Augustus (27 BC -

14 AD) established a law limiting the height of a building to 70 feet and banning buildings over 7 stories because of frequent collapses of buildings.

Furthermore, during Nero's era (54 - 68) they improved the roads after a great fire and limited the height of a building to less than or equal to twice the width of the road a building was facing.

The Roman Building Code not only limited the height of buildings but also provided regulations on lighting, windows, and drainage. Concerning design and construction techniques, too, it is said that the Romans had considerably advanced methods for the time. Therefore, we can say that various present building codes originated in the Roman era.

In England building codes gradually developed on the basis of customary laws formed during the period from the 11th century to the 12th century.

A law regarding a boundary wall in the twelfth century or thereabouts provided as follows: "When two or more neighbors build a stone wall on their boundary, each must provide 1.5 feet of his land. In this case, they must construct a stone wall with thickness of 3 feet and height of 16 feet on the boundary at their own expense." When both parties agreed, it allowed them to increase the height of a wall even further at their own expense. This code also banned straw-thatched roofs. They had a concern for fire protection. The historically famous Great Fire of London in 1666 gave a momentum to a further strengthening of regulations on fire protection in the English building codes. Christopher

15

Wren's plan for the restoration of London after the Great Fire was a splendid work in terms of urban planning. Unfortunately it was never realized. Nevertheless, the building codes were substantially improved in order to restore London. The building code provided that all outer walls of a building must be made of brick or stone (fire protective structure) and all door frames and window frames must be made of hard oak material. At this time the mayor's authority was defined and the institutions of inspector and supervisor were established. Later the English building code was further developed, particularly in the fire protection area. During the reign of Queen Victoria the Metropolitan Building Act of 1844 provided for administration of building regulations by dividing buildings into three groups in accordance with their usage. It formed the base for the form of present building laws. (page 4) The first group was residential buildings. The second group included warehouses, stores, grain elevators, breweries, distilleries, working places, and barns. The third group included churches, towers, universities, halls, hospitals, theatres, concert halls, dance halls, public halls, museums, and other special buildings where many and unspecified persons gathered. The Act provided rules and regulations based on the purpose and function of a building. By this act the height of the outer walls of buildings in the first group was limited to 85 feet. This act entirely revised in 1894 and the London Building Act was newly established. This act limited the absolute height of a building to 80 feet. For reference, I will list the items contained in this act: construction and expansion of streets,

the front yard of a building, street names and lot numbers, vacant space required around the building, the height of a building, the structure of a building, special wooden temporary buildings, the legal relation between a building and the owner of the adjoining land, dangerous and harmful commerce, residential buildings in low level land, lighting conditions, management of construction, architects and land investigators, legal procedures, miscellaneous regulations, and acts. The current English building code is generally classified into two groups: the Greater City of London Code based on the Public Health Law and laws applied to other counties. But the contents are a development of the previously-mentioned act.

Historical trends growing out of the Roman and English building codes have been independently evolving on the European Continent and in America for many years. Thus, the present system of building codes was established in various countries.

In the United States the authority for making and administering laws on buildings belongs to each incorporated township. Therefore, there are many cases when two townships have unique, different regulations even though they are adjoining townships within the same state. In order to adjust differences, various professional organizations such as the International Building Directors Council whose membership includes incorporated townships, the American Building Directors Council, and the Southern Building Codes Alliance have published samples of recommended building codes. In fact, except large cities in the east and midwest, most of townships choose and arrange appropriate items suitable

for them and adopt them as their building codes. Among those samples of recommended building codes, the most well-known to Japanese is the Uniform Building Code published by the International Building Directors Council. As for a zoning code, the samples of recommended codes are published by the American Urban Planning Studies Association, the American Planning Directors Council, and others. Canada has adopted a system similar to the United States. (page 5) As for a sample of a recommended code concerning fire protective regulations, the National Building Code by the National Fire Insurance Association is well-known.

2. (2) The History of Building Regulations in Japan

Judging from the historical trend of building codes, the Building Standards Law currently in effect in Japan, or its predecessor, the Urban District Building Law, are based on principles originating in Western building codes. However, Japan also had its own building codes in the past. The Taihō Law Codes of 701 prohibited builders of private mansions from constructing multistoried buildings for the purpose of observing other people's houses. This is said to be the first building regulation in Japan. A similar concept can be found in the present Civil Law Act's Article 235; "Anyone who builds a window or a porch overlooking someone's lot within 1 meter of the boundary must equip it with shutters." We have another example of a building code around 1030 during the reign of Emperor Goichijō. Concerned with the spiritual decline of provincial governors and their houses becoming too luxurious, the central government limited

the size of a lot for a provincial governor's residence from exceeding one quarter of one square chō (1 chō = 109 m), which equalled one block in residential areas of Kyoto at that time. It also banned all court officials below the sixth rank from building walled fences around their houses and from building houses with roofs made of Japanese cypress bark. During the Fujiwara period (858 - 1094) only court officials above the third rank and councilors above the fourth rank were allowed to build gate houses facing streets. These building regulations were in one sense intended to prevent luxury. But they were mainly attributable to the aristocracy's tendency to stick to formalities during that time. There were no obvious building codes found during the Kamakura, Muromachi, and Sengoku eras. During the Edo period (1603 - 1867), thanks to an almost 300-year long period of peace, considerable documentation of the building codes have been preserved. The contents of these building codes can be roughly classified into three groups: (1) Those concerning formalities maintaining feudal class distinctions, (2) those enacted for the sake of frugality, and (3) those concerning fire protection. The third group of fire protective regulations had never been seen in Japanese building codes before. This was an inevitable requirement of the society during the Edo period, for many fires had occurred in Edo. Among the fire prevention regulations were requirements to cover a house tops and to encourage construction of mud wall warehouses and plastered houses. It is said that the Great Fire of 1657 in Edo burnt down the keep of Edo Castle and caused the death of 108,000 people.

As a result of such great fires, firefighting facilities were greatly improved. In 1660 an order was issued to cover cogon-grass, straw, and shingle thatched roofs with mud. (page 6) As for tiled roofs, since the weight of roofing tiles was quite heavy at that time, there was a great danger of collapse at the time of a fire. So tiled roofs were banned for a certain period. However, after pantile was invented in 1674, the Edo Government in 1720 issued an order encouraging tiled roofs.

The first regulation issued after the Meiji Restoration (1867) was the Tokyo Prefecture's Notification issued after the Great Ginza Fire of 1872. In this notification brick buildings were divided into several classes and height limits and required thicknesses for walls were established for each class. The government itself built brick buildings in accordance with the specifications described in the notification and sold them to the private sector. The structure and construction method for brick buildings were a direct import from the West, and they were demolished in the Kanto Great Earthquake of 1923. After the great fire of 1879 the government selected several fire prevention roads along with issuing regulations concerning house tops. Only three kinds of buildings, those made from brick, stone, and mud wass, were permitted to be built on the two sides of the fire prevention roads. This was the beginning of today's fire prevention roads. However, this code was never enforced due to the extreme difficulty of carrying it out. The first, nominally and virtually modern, comprehensive building code in Japan was probably Shiga Prefecture's House Building Regulations of 1886.

These were very excellent building laws. This included minimum required sizes for residential houses and a mandatory requirement for toilet equipment. It also included very basic items which our current laws have not been able to provide yet. Regretably, these regulations were repealed when the Urban District Building Law was issued and became effective in 1919.

After Osaka Prefecture issued the Osaka Prefectural Building Control Regulations in 1909, various cities in Japan adopted local building codes. And then, in 1919 the Urban District Building Law was issued and enforced.

3. (3) The History of the Building Standards Law

In order to learn the history of the Building Standards Law, we need to go back to study the process of the establishment of the Urban District Building Law.

In accordance with the recommendation of the City Replanning Committee of 1887, Dr. Tsumaki drafted a building code. But it was not presented for legislation. For a while discussion of the building code ceased. In 1906 the City of Tokyo recognized the need for a building code. The then mayor, Ozaki, commissioned the Architectural Association to write a draft. The Architectural Association set up a committee and spent six years preparing the building code bill. A committee presented the mayor of Tokyo with the draft. This draft led to the establishment of today's Japanese building code. This draft, however, did not become a law, either. Then, the demand for establishment of a uniform nationwide building code became increasingly strong in major cities.

(page 7) With the incorporation of the Kansai Architectural association and other organizations, the Architectural Association established an executive committee in 1917 and appealed to the ministers concerned and members of both the House of Peers and the House of Representatives concerning the necessity of a uniform building code. In 1918, with the agreement of the then Minister of Home Affairs Shinpei Gotō, the central government established the Urban Planning Study Committee under the chairmanship of the Minister of Home Affairs. At the same time the Urban Planning Section was newly established in the Ministry of Home Affairs. The central government had finally decided to promote the legislation on urban planning and buildings. The leadership of Doctors Shōzō Uchida and Toshirō Kasahara in establishing the Urban Planning Law and Urban District Building Law is still fresh in our memories. Thus, on April 5, 1919, the Urban Planning Law (now defunct) and the Urban District Building Law (the predecessor of the Building Standards Law) were issued. These were fundamental laws for construction of cities in Japan.

The Urban District Building Law was applied to only the six largest cities, Tokyo, Kyoto, Osaka, Kobe, Yokohama, and Nagoya, from December 1, 1920. Later more cities were added and eventually it was applied to most major cities in Japan. However, during World War II and for several years after the war, the law was not enforced due to wartime conditions. In 1948, when building control under the Temporary Building Restriction Regulation based on the postwar Temporary Commodities Adjustment Law was lifted, the Urban District Building Law was enforced again.

However, in order to administer building policies suitable for the postwar democratized society, and in relation to the bill on registered architects that was being proposed at that time, many people requested a complete revision of the Urban District Building Law. The Ministry of Construction started working on a draft of a completely revised version from 1949. The draft became the Building Standards Law in 1950. Since then several revisions had been added. However, in order to respond to the trend toward high rises and large scale buildings, the urbanization phenomenon, and the development of new technology, a complete revision was made in 1970. This was the greatest revision since the law became effective. The newly revised law came in effect in January of 1971. As for the Urban Planning Law, a complete revision was made in 1968. It went in effect in 1969. Later, items such as shade regulations and district planning have been newly added. As government ordinances, the Earthquake Resistant Design Regulation has been newly adopted. All those revisions made the building code what it is now.

SECTION II Outline of Various Laws and Ordinances Concerning Buildings

In the previous section I defined a building code as "the conditions and order necessary to construct and maintain (use) buildings required by the society." If we survey all laws and regulations related to buildings in accordance with this definition, we know they are wide ranging and diversified. To say nothing of memorizing them, it is difficult even to read them all.

Let us take the example of housing. Laws concerning the preparation of building funds include the Housing Loan Corporation Act, the Industrial Workers Housing Funds Accomodation Act, the Housing Finance Insurance Act, the Housing Association Act, and other ordinances authorizing local governments to finance housing.

If you want to purchase a lot to build a house, you require knowledge of urban planning restrictions such as the Use Restriction District Item of the Building Standards Law, the Residential Land Formation Control Act, the Lots and Building Exchange Business Act, the Real Estate Registration Act, and the Special Taxation Measures Law. Furthermore, if you want to buy a condominium, you need to study the Law Concerning Sectional Ownership of the Building.

In the case of building itself, in addition to the Building Standards Law, which is the primary law concerning lot, structure, and facilities, there are many other laws and regulations governing the structure and facilities of a building. As for fire fighting facilities, one must follow the Fire Services Act. When constructing a place of business (factory, office, store, etc.), we need to know the Labor Safety and Sanitation Act. In the case of building inns and hotels, we need to know the Hotel Business Act. One must also follow the Entertainment Facilities Act when building a theatre, and the Ordinance on the Control of Dangerous Substances when constructing a building equipped with an oil-fired boiler.

On daily use of a building (maintaining and managing a building) the Building Standard Law provides the basic general

conditions. In addition, the Fire Services Act stipulates whether or not establishment of a fire protection manager is required. The Labor Standards Act requires maintenance of a safe and healthy working environment in a palce of business. The laws concerning disposition of waste and the cleaning of a building control the maintenance and management of waste disposal facilities and raw sewage treatment facilities.

Finally, there arises the question of how a construction engineer should study the enormous quantity of building-related laws and regulations and how he should reflect his study in his everyday work. It is almost impossible and, practically speaking, not necessary to memorize all the laws and regulations.

The best way is first to be aware of the existence of these laws and regulations and to grasp systematically the legislative intentions inspiring the laws. Then, as practical necessity requires, you refer to and check with specific articles of the laws.

(page 9) Here, I classify and list the laws and ordinances that the construction engineers who design, supervise construction of, or actually build structures need to know in their work.

1. (1) Laws and Ordinances Concerning Lot, Structure, and Facility

1. The Building Standards Law, the Building Standards Law Enforcement Ordinance, the Building Standards Law Enforcement Regulations, Ministerial Notifications

These measures provide necessary technical standards in terms of safety (structural strength), fire prevention, and sanitation. In addition, in order to form a

healthy urban district, they regulate a system for dividing land by use, the building-to-land ratio, the volume ratio, height, and other matters. These are the so-called basic building laws.

2. The Fire Services Act, the Fire Services Act Enforcement Ordinance, the Fire Services Act Enforcement Regulations

These measures provide for the organization and function of public fire fighting institutions. They also provide standards for establishment of fire fighting facilities (fire extinguishers, fire hydrants, sprinkler systems, fire alarm systems, escape ladders, and evacuation guide signs) in large scale buildings.

3. The Labor Standards Act, the Labor Safety and Sanitation Act, the Labor Safety and Sanitation Regulations, the Business Affiliated Dormitory Regulation

These measures also provide technical standards for buildings in order to maintain safety and sanitation (the working environment) of workers at factories and other places of business. Among them, some repeatedly provide many items with the same spirit and intention as the Building Standards Law.

2. (2) Laws and Ordinances Concerning Buildings for Special Use

The following are the examples of buildings for specific use for which specific laws and regulations provide the standards for facilities. However, as a technical standard many of the items are rather abstract.

Schools (the School Education Law, the High School Building

Standards; the Kindergarten Building Standards)

Hospitals (the Medical Law; the Medical Law Enforcement Regulations)

Pharmacy (the Drugs, Cosmetics, and Medical Instruments Act; Pharmacy Structure and Equipment Regulations)

Child Welfare Facilities (the Child Welfare Act; the Child Welfare Facility Minimum Requirement Standards)

Slaughterhouses (the Slaughterhouse Act; the Slaughterhouse Act Enforcement Ordinance)

Parking Garages (the Parking Garage Law; the Parking Garage Enforcement Ordinance)

Motor Vehicle Terminals (the Motor Vehicle Terminal Act; the Motor Vehicle Terminal Structure and Facilities Ordinance)

3. (3) Laws and Ordinances Concerning Business Licenses

Many of the laws and regulations concerning business licenses provide certain standards for the facilities and equipment required for the granting of business licenses. As a technical standard, they are often abstract. Primary examples of such laws are the Act to Control Business which may Affect Public Morals (cabarets, houses of assignation, dance halls, bars, mah jong parlors, pin ball parlors, etc.), the Pawnbrokerage Act (storage of pawned property, etc.), the Food Sanitation Act (page 10)(restaurants, food processing facilities, etc.), the Entertainment Facilities Act (movie theatres, theatres, etc.), the Public Bath House Act (public bath houses), the Hotel Business Act (inns, hotels, flophouses, etc.), the Law Concerning Retail Sales Business Activities in Large-scale Retail Stores

(department stores, supermarkets, etc.), the Barbershop Law (barbershops), the Beautician Law (beauty parlors), and the Warehouse Business Act (warehouses).

4. (4) Laws and Ordinances Concerning the Handling, Storage, and Disposition of Dangerous Substances

Many laws provide specific and detailed technical standards from the viewpoint of preventing fire and other hazards. Important laws are Ordinances Concerning Control of Dangerous Substances (the Fire Services Act), the Explosives Control Act, the High Pressure Gas Control Act, and the Law Concerning Preservation of Safety and Normalization of Exchange of Liquefied Petroleum Gas (the so-called Liquefied Petroleum Gas Law).

5. (5) Laws and Ordinances Concerning Building Facilities

In addition to the standards provided in the Building Standards Law, detailed technical standards are provided in the following laws: the Electricity Enterprises Act (Ministerial Ordinance to Determine Technical Standards for Electrical Facilities), the Liquefied Petroleum Gas Law, the Gas Enterprises Act, the Waterworks Act, the Fire Services Act (fire fighting facilities), and the Law Concerning Preservation of Sanitary Environments in Buildings (management and maintenance of building facilities in specially designated buildings.).

6. (6) Laws and Ordinances Concerning Urban Planning, Land Utilization, Environmental Protection and Anti-pollution Measures

Major laws are the following: the Urban Planning Law (refer to Chapter 3, Section I), the Urban Redevelopment Law; the Urban Park Law; the Harbor Law; the Sewage Law; the Parking

Garage Law; the Land Readjustment Law; the New Residential Urban District Development Law; the Residential Lot Formation Control Law; the Law to Promote Expansion of Public Lands; the New Urban Bases Improvement Law; the Industry Rearrangement Promotion Law; the Law Concerning Prevention of Disasters Caused by Erosion of Steeply Sloping Land; laws concerning improvement of waysides of major roads; the Road Law; the National Motor Vehicle Expressway Law; the Road Traffic Act; the Civil Aviation Act; the Wireless Telegraphy Act; the Nature Park Act; the Urban Greenbelt Preservation Law; laws concerning development and improvement or control of the national capital region, the Kinki region, the Chubu region, Nara, Kyoto, Kamakura, and Asuka-mura. As for environmental protection, the Natural Environment Protection Act, the Water Pollution Prevention Act, the Air Pollution Prevention Act, the Noise Control Act, the Waste Disposal Act, and the Offensive Odor Prevention Act are the primary laws.

7. (7) Laws and Ordinances Concerning Promotion of Construction and Development

They are the Residential Houses Construction Planning Law, the Public Housing Law, the Housing Loan Corporation Act, the Japan Housing Corporation Act, the Local Housing Supply Corporation Act, the Hokkaido Protection-against-Cold Houses Construction Promotion Act, the Housing Association Act, the Rental Housing Association Act, the Residential District Improvement Act, the Urban Redevelopment Act, the Law Concerning Improvement of Distribution Business Districts, the Housing Sites Development Corporation Act, and the Regional Improvement Promotion

Corporation Act.

(page 11)

8. (8) Civil Code and Other Laws and Ordinances Concerning Legal Rights

The laws I have listed in (1) through (7) are all 'public laws.' They have been established on the basis of a public interest such as the welfare of the people. Even if the concerned party and the directly interested parties in the neighborhood agree to or understand that they bear a certain risk, the concerned party cannot be exempted from the control of these laws. In other words, the enforcement agencies exercise public powers to enforce these laws and regulations on a mandatory basis.

On the other hand, "private laws" such as the Civil Law Act adjust interests between private citizens. It is necessary to remember that the Civil Law Act is different in nature from those laws listed in (1) through (7). However, the Civil Law Act includes some articles on buildings in the neighborhood relations section. For instance, the Articles 206 through 265-2, in particular Articles 234 (The outer walls of a building must be at least 50 cm inside the boundary with an adjoining lots.) and 235 (Windows of a building must be at least 1 meter away from the boundary with an adjoining lot.) regulate buildings. These rules are the standards neighbors must observe. Even if one does not respect these rules, the enforcement agencies do not intervene to impose them upon the negligent party. (Of course, a final settlement depends on a court decision.)

In order to clarify legal rights concerning buildings and building-related matters or to adjust the rights of individuals,

the Real Property Registration Act, laws concerning the protection of buildings, the Land Lease Act, the Building Lease Act, and the law concerning sectional ownership of buildings (in regard to the ownership of a portion of a building such as a condominium, which was established as special rule in the Ownership Items of the Civil Law Act) have been established.

III Basic Knowledge for an Understanding of the Building Code

As I have already mentioned in Section II, it is unnecessary for a general construction engineer to memorize the enormous sections of the building code. (it is also impossible). Instead, you should try to know what sort of laws and ordinances exist, and to grasp a rough idea of the purposes for which they are composed. Then, you should refer to the appropriate article of the laws and regulations whenever a specific need arises in your work. I meant to point out that it is important to make a habit of using a book of the collected laws as a dictionary. (page 12) I wrote Section III so that you can understand the exact meaning of articles when you check with the specific article. There is no need to become a law specialist. But one must have the minimum necessary knowledge of law to read and understand its provisions, in other words, one must know the rules applied to writing provisions of a law.

1. (1) Kind of Laws and Ordinances

- (1) Constitution ... a law determining the basic organization and activities of a nation. Needless to say, a constitution is the highest law of a nation.

- (2) Law ... a law enacted by passage in the Diet. Restrictions on people's rights or regulations imposing some obligations on people are generally provided in laws.
- (3) Orders enacted by the government organizations (Generally they are issued under the authority of a law.)
- (i) Government ordinance ... an order decided by the cabinet.
 - (ii) Ministerial ordinance ... an order issued by the minister of any one ministry. An ordinance from the Prime Minister's Office carries the same authority as ministerial ordinances.
 - (iii) Others ... There are some regulations enacted by the Board of Audit and the National Personnel Authority. However, they have little to do with the building code.
- (4) Local government codes
- (i) Regulations... a local government (Generally this means both prefecture level and city, town, and village level.) decides them in a legislative body.
 - (ii) Rules ... an order issued by the head of a local government.

Taking the example of the Building Standards Law and its related ordinances, the Building Standards Law is a law, the Building Standards Law Enforcement Ordinance is a government ordinance, and the Building Standards Law Enforcement Regulation is a Ministerial ordinance (Construction Minister's Ordinance). Basically, a law defines the basic character of a restriction or

control; a government ordinance determines specific and detailed items, and a Ministerial ordinance determines procedural matters. Generally speaking, "enforcement ordinance" is used as the title of a government ordinance and "enforcement regulation" is used as the title of a Ministerial ordinance.

As for regulations and rules of local governments, each prefecture has a Building Standards Law Regulation and Detailed Regulations on Building Standards Law Enforcement. These titles can vary somewhat by prefecture. In order to avoid confusion with the Building Standards Law Enforcement Regulation promulgated by a prefecture usually uses the words "detailed regulation" for its own code.

(page 13)

2. (2) The Form of Laws and Ordinances

A law or ordinance is generally composed of a title, main provisions, and supplementary provisions. It is announced to the public in an official gazette. This form is explained by using the Building Standards Law as an example:

Title and law number	{	The Building Standards Law (1950 Law No. 201)
Table of contents	{	Table of contents Chapter 1 The General Provisions (Articles 1 - 18) (ellipsis) Supplementary provisions
Main Provisions	{	Chapter 1 The General Provisions (Purpose) Article 1. This law has been enacted for the purpose of (ellipsis)

Supplementary provisions	}	Supplementary Provisions (the date the law goes into effect) 1. This law becomes effective on the date determined the government ordinance
		(ellipsis)
Separate Tables	}	Separate Table No. 1 (omission)

Laws and ordinances are numbered serially for each calendar year by kind and enactor. The date and month are not formally included. But for convenience sake, the collected laws and ordinances usually include the year, month, and date along with the law number. The Building Standards Law is the 201st law issued in 1950. If a law is indicated only by the title, sometimes it causes confusion. If a law is indicated only by the law number, it does not reveal anything about the content of a law. For this reason, a law is formally indicated by both the title and the law number.

The main provisions are the substantive provisions concerning the subject of a law. The supplementary provisions include the effective date and processing steps. The main provisions are composed of "articles." An article usually has a "headline." When necessary, one article is divided into two or more items by the content of the provision. An "item" is, so to speak, a paragraph in laws and ordinances. The first item is not specifically indicated. The second and all subsequent items are indicated only by the Arabic numerals 1, 2, 3 Items are distinguished in a manner different from articles. (page 14)

If some of the contents do not require separate items, they can

be included in a single item. In such a case there are two sentences in one item. The provision of the first sentence is called the preceding part and of the second is called the latter part. When one item contains two sentences, the latter part sometimes begins with "provided that." This determines the exceptional cases to which provision of the preceding part applies. In such a case the provision of the preceding part is called the "main text" and the sentence beginning with "provided that" is called the proviso. In the item or article, subordinate statements are also indicated by Arabic numerals. If subordinate statements are further subdivided, English letters A, B, C, ... are substituted for reasons of convenience.

Let us take the Building Standards Law Article 85 as an example.

Headline		Easing of Restrictions on Temporary Buildings
		Article 85 In case of disaster, if the occurrence of a disaster is, this does not apply.
Item 1.	{	1. (1) If the central government, local governments, or Japan Red Cross....
		2. (2) If the victim builds solely for the purpose of his own use....
Item 2.	{	2. Built when stricken by a disaster, this does not apply....
	{	Provided that within the fire prevention district or, it applies....
Item 3.	{	3. Those who build the emergency temporary buildings described in Item 2...., it can permit....
(Everything after Item		3 is omitted.)

3. (3) Vocabulary of Laws and Ordinances

"Ika (equal to or less), ijō (equal to or more), izen (on or before), igo (on or after), koeru (exceeding), miman (less than)"

In comparisons of quantity, volume, or time elapsed, "ika, ijō, izen, and igo" and other terms beginning with i include the base point for reckoning in legal terms. On the other hand, "koeru" and "miman" do not include the base point of reckoning. For instance, the Law, Article 6, Item 1, 2 says, "wooden buildings of 3 stories or more, or whose gross floor area exceeds 500 square meters." In this case a building with 3 stories is included and a building whose gross floor area is 500 square meters is not included.

"Oyobi (and), narabini (and)"

When two nouns or verbs are listed in annexed manner, "oyobi" is always used. (page 15) When three or more nouns or verbs of the same kind are listed in parallel, all but the last one are connected by a comma and the last one is connected with "oyobi." In the case of a complicated sentence with varied degrees of connection, "narabini" is used for the primary connections and "oyobi" is used for the secondary connections. Let us take the Law, Article 20, Item 1 as an example. "Buildings must have a structure safe in terms of empty weight, loaded cargo weight, fallen snow, wind pressure, earth pressure, oyobi (and) water pressure narabini (and) earthquake and other vibrations oyobi (and) impacts." In this case, empty weight, loaded cargo weight, fallen snow, wind pressure, earth pressure, and water pressure are all connected by oyobi to form one group and

36

earthquake, other vibrations and other impacts are connected by oyobi to form another group. The former group and the latter group are connected by narabini.

"Matawa (or), moshikuwa (or)"

When two nouns, verbs, or clauses are listed selectively, they are connected by matawa. In the case of more than two, all but the last one are connected by a comma and the last one is connected by matawa. When a sentence is complicated with varied degrees of selective connection, matawa is used for the primary selective connections and moshikuwa is used for the secondary selective connections. This rule is not consistent with the use of the inclusive conjunctions "oyobi and narabini." It has, nevertheless, been conventional usage for a long time. Let us explain this by using the Law, Separate Table 2, Item E [Sic], 3, (15) as an example. It says, "When casting printing type moshikuwa (or) metallic art work matawa (or) smelting metals, one must use a melting pot matawa (or) a furnace whose total volume does not exceed 50 liters." "Printint type" and "metallic art work" are selectively joined by moshikuwa. "Casting printing type or metallic art work" and "smelting metals" are selectively joined by matawa. "A melting pot" and "a furnace" are selectively joined by matawa. If "a melting pot" and "a furnace" were selectively joined by "moshikuwa," the clause, "one must use a melting pot or a furnace," only applied to "smelting metals."

"Junyōsuru (apply corresponding provisions to other cases)"

Provisions of similar content do not have to be written repeatedly. "Junyōsuru" means relevant provisions apply with

necessary modifications. Let us take the Law, Article 87-2, Item 1 as an example. It says, "When building an elevator and other building facilities specified by government ordinance in a building specified by Article 6, Item 1, 1 through 3, provisions of Article 6 (junyōsuru) apply." In this case a clause in the Law, Article 6, Item 3, "...for those specified by Item 3, 1 through 3, within 21 days after the application is received, for those specified by Item 3, 4, within 7 days after the application is received...." is modified to "within 7 days after the application is received" and provisions of Article 6, Item 3 apply. The Law, Article 88, Item 1 provides only items that apply with necessary modification to smokestacks, advertising towers, highrise water tanks, breastworks, other structures and elevators, amusement facilities such as roller coasters and flying towers, and other structures. (page 16) It does not provide any modifying notes, because it is clear what modifications are necessary to apply the provision.

SECTION IV Characteristics and the Range of Application of the Building Standards Law

1. (1) Characteristics of the Building Standards Law

First, the Building Standards Law is integrated into the single legal format of the Building Standards Law. In Western countries the building code (regulations concerning aspects of building safety such as structure, fire prevention, and sanitation), and the zoning code (regulations concerning regional control within an urban planning district) are under separate legal

formats. In Japan, however, not only the building code and the zoning code, but also the housing code, the structural code, the sign code and a part of various kinds of building and facility controls are all integrated in the Building Standards Law.

Second, as I mentioned in Section I, local governments, such as states and incorporated townships, independently adopt and enforce building codes in foreign countries. Japan, in contrast, has a uniform nationwide law called the Building Standards Law. (However, under limited conditions the law can be supplemented or eased by local legislation.)

Compared to conditions in the United States, where each incorporated township individually legislates a building code, this uniform nationwide legal format has a great advantage in standardizing technology, manufacturing construction materials, and the distribution of parts and materials over a wide area. Many concerned people in foreign countries have highly evaluated this feature.

The previously mentioned building code is a technical standard for structural durability, fire prevention (and fire escape), and sanitation required to preserve the safety of individual buildings as single units. The standards are described in Chapter 2 (Articles 19 through 41) of the Building Standards Law, Chapters 2 through 5-3 (Articles 19 through 129-15), Chapter 7-2 (Articles 136-2 through 136-7), and Chapter 9 (Articles 144-2 through 149, some parts excepted) of the Building Standards Law Enforcement Ordinance.

The zoning code sets standards for preserving order among

buildings to ensure the safe and rational use of land necessary in cities and towns, which consist of a collection of buildings. (page 17) Therefore, zoning codes only apply to buildings within urban planning law designated districts, where a systematic land use plan exists.

Specifically, the zoning code includes regulations on the relation between a building (its lot) and a road, districting by use, restrictions on a building's form (the building-to-land ratio, the volume ratio, height limits, and shade restrictions), fire prevention district systems, and others. Those regulations are given partly in Chapter 3 (Articles 41-2 through 68) of the Building Standards Law but mostly in Chapters 6 and 7 (Articles 130 through 136) of the Building Standards Law Enforcement Ordinance.

Third, the Building Standards Law provides for an administrative action called "building certification" to judge whether or not a building meets the standards described in all the relevant laws. For that purpose an administrative organization called the Building Directorate is established to carry out building certifications. Building certification is, strictly speaking, an administrative action called "restricting action (formerly it was called 'binding action')." It involves judging fitness and verifying conformance to all technical standards (including those provided by laws and ordinances other than the Building Standards Law) relevant to the building (lot, structure, and facilities) for which application has been made for building certification. In other words, it is to judge "an observance is an

observance" and "a violation is a violation." In this respect certification is essentially different from "permission." Permission (or "approval" with limited discretion) is a discretionary action, and it is fundamentally different from certification. In this connection, under the Building Standards Law, authority to grant permission belongs to prefectural governors or mayors of cities that have established Building Directorates. (Refer to Chapter 4 and the definition of terms in Appendix 1 of this book.)

The fourth characteristic is that the Building Standards Law literally possesses the characteristics of a basic building law. This is shown by the fact that the technical standards applied in certification proceedings by the Building Directorates described in Law, Article 6, Item 1, include not only those standards described by the Building Standards Law but also the technical standards concerning site, structure, and facilities described in other building-related laws (even though they are limited only to those consistent with the previously mentioned restricting action.)

Furthermore, Article 8 of the Building Standards Act provides that an owner, manager, or occupant of a building always has an obligation to make an effort to maintain the site, structure, and facilities in a lawful state. A lawful state also means fulfilling all technical standards described by building-related laws concerning site, structure and facilities of a building. This also demonstrates that the Building Standards Law is a basic building law.

(page 18) Provisions of Article 8 of the Building Standards Law do not directly specify penalties for violation. However, it is obvious that Article 9 of the Building Standards Law (measures against unlawful buildings) applies to the occurrence of conditions not in conformity with the Building Standards Law as a result of improper maintenance and management. Also, when the condition of a building is not in conformity with other laws, it is expected that proper measures will be taken under the respective law.

The fifth characteristic is, as seen in the previously mentioned Building Standards Law's Article 8, that most provisions of the Building Standards Law are not only design and construction standards for the construction stage but also constitute technical standards that must be observed from a building's first use after completion till its final removal or destruction. In this sense, these provisions are called "standards for condition." Many building engineers, however, lack recognition of this aspect.

2. (2) The Structure and Range of Application of the Building Standards Law

As I mentioned in the previous section, the building code is provided in Chapter 2 and the zoning code is provided in Chapter 3 of the Building Standards Law. Chapter 1 is titled General Provisions and details the scope within which the law is applied, its principles, organizations and institutions for enforcement of the Law, and necessary procedures. Moreover, supplements to the provisions described in Chapter 1 are provided

in miscellaneous provisions of Chapter 6.

Chapters 4 and 5 cover items concerning building agreements and the Building Council respectively. The final chapter, Chapter 7, contains penal provision.

Separate Table 1 "Special Buildings that Must Be Fireproof or Simplified Fireproof Structures," Separate Table 2 "Restrictions on Buildings within the Designated Use Districts," and Separate Table 3 "Shade Restrictions on Intermediate- and High-Rise Buildings" are based on provisions of Articles 27, 48, and 56-2 respectively. They could have been described with each article. But, due to great length of the tables, they are included in separate tables to make them simpler and more easily understandable. These tables are also often referred to in various articles of both the Building Standards Law and the Building Standards Law Enforcement Ordinance. Separate tables are easier to refer when reading through various articles of the laws. (For example, Separate Table 1 is referred to in the Law, Article 6, Item 1, 1; the Law, Article 35; the Law, Article 35-2; the Law, Article 35-3; the Law, Article 90-3; the Ordinance, Article 115-2; the Ordinance, Article 117; the Ordinance 126-2; the Ordinance, Article 126-4; and the Ordinance, Article 128-4.) (page 19) What we must remember about the range of application and principles recorded in Chapter 1 is that the range of buildings to which the building certification provision is applied (the scope of application for the procedural provision) and the range of buildings to which technical standards are applied differ. I will explain procedural provisions in Chapter 4 of

this book. The Table and Figure 1 shows the range of buildings to which the building certification provision is applied and the range of buildings to which the technical standards (also called the substantive provisions) are applied.

Table and Figure 1

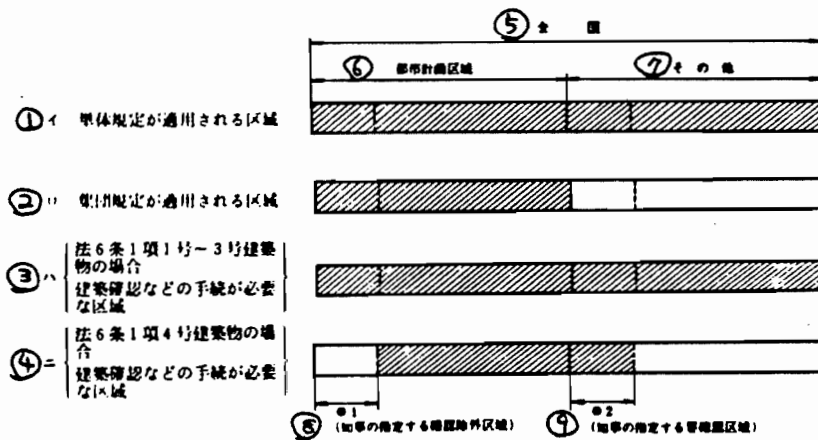

Keys

1. Areas where the building code is applied.
2. Areas where the zoning code is applied.
3. The case of buildings specified in the Law, Article 6, Item 1, 1 through 3.
Areas where procedures such as building certification are required.
4. The case of buildings specified in the Law, Article 6, Item 1, 4.
Areas where procedures such as building certification are not required.
5. National
6. Urban planning district
7. Others
8. *1 (Districts designated exempt from building certification)

by prefectural governors.)

9. *2 (Districts where the building certification is required by designation of the prefectural governors.)

Buildings in areas indicated by ⑧*1 are not required to have the building certification from building directorates (procedures not required), but are not allowed to violate either the building or zoning codes. Buildings in the areas described by ⑨*2, where the urban planning laws are not applied, the zoning code is not applied either. However, the building code is applied and the building certification by the building directorate is also required. Thus, applicability of building certification and conformity to technical standards (substantive provisions) are not related. We must pay attention to this point.

3. (3) Exemptions from Application of Technical Standards (Substantive Provisions)

As I mentioned in (1), the Building Standards Law applies uniformly to all buildings in Japan. However, as I mentioned briefly in (2), there are some cases in which the Law is applied because of escape clauses and exemptions based on the purpose and intention of the each item of the Law and characteristics of buildings.

Cases where procedural provisions are exempted will be explained in Chapter 4 of this book. Here, Table and Figure 2 shows the principal cases when technical standards (substantive provisions) are exempted.

(page 20) In addition to those described in Table and Figure 2,

Keys

1. Article and item referenced.
2. Buildings exempted from application of substantive provisions.
3. Provisions not applied.

A-1. Law, Article 3, Item 1.

(Exemption from application to cultural properties.)

A-2. (1) Buildings designated (or tentatively designated) on the basis of the Cultural Properties Protection Act as national treasures, important cultural properties, important tangible ethnic cultural properties, special historic and natural scenic monuments, and historic and natural scenic monuments.

(2) Buildings of important art works certified under once applicable laws concerning preservation of important art works.

(3) Reconstructed buildings of (1) and (2). (Only those approved by concerned government agencies with the agreement of the Building Council.)

A-3. Entirely exempted. (All provisions of the Building Standards Law and other ordinances and regulations based on the Building Standards Law.)

B-1. Law, Article 3, Item 2.

(Exemption from application to already existing buildings.)

B-2. At the time the Building Standards Law (and other ordinances and regulations based on the Law) became effective:

(1) Buildings and lots that are already in existence and did not meet the provisions.

(2) Buildings and lots whose construction (building, repairing, and remodeling) was in progress and did not meet the provisions.

(3) Parts of the previously described buildings that did not meet the provisions.

(Reference: Special provisions concerning exemption from application to regulated buildings (local government regulations) within the district planning and wayside improvement planning zones are determined by local government regulations. [Law, Article 68-2, Item 3])

B-3. Among the provisions of the Building Standards Law (and other ordinances and regulations based on the Law), inappropriate portions are exempted.

Note: Buildings violating any laws once applicable are excluded from the exemption. Also, as a principle, even though a building was constructed prior to the Building Standards Law, if it is remodeled, improved, repaired on a large scale after the Law goes into effect, the exemption from application is cancelled. Detailed regulation on this matter are omitted here.

(Law, Article 3, Item 3; Law, Article 86-2; Ordinance, Article 137 through 137-9)

C-1. Law, Article 38.

(Special materials and structures)

C-2. Buildings using special construction materials and structural methods that are not anticipated by the provisions of Chapter 2 of the Building Standards Law (and other ordinances

and regulations based on the Law) and approved by the Minister of Construction.

C-3. Among the provisions of Chapter 2 of the Building Standards Law (and other ordinances and regulations based on the Law), unrelated and inappropriate portions are exempted. (Refer to Chapter 2, Section I, (4) of this book.)

D-1. Law, Article 41.

(Easing of regulations by municipal ordinance)

D-2. Buildings within areas designated by a municipal ordinance with the approval of the Minister of Construction. (Except those described in the Law, Article 6, Item 1, 1 through 3.)

(Note: Including ordinances and regulations based on these articles.)

(page 21)

E-1. Law, Article 41-2.

(Areas where Chapter 3 of the Building Standards Law is applied.)

E-2. Buildings outside urban planning districts.

E-3. All provisions of Chapter 3 of the Building Standards Law (Law, Articles 42 through 68) are exempted.

(Note: Including ordinances and regulations based on these articles.) (Refer to Chapter 3, Section I, (2) of this book.)

F-1. Law, Article 43, Item 1.

(Conditions and requirements for a lot abutting a road)

F-2. Lots with no hazard in terms of safety, such as a lot a large vacant space around it.

F-3. The provisions of Law, Article 43, Item 1 are exempted.

(Refer to Chapter 3, Section II, (3) of this book.)

- G-1. Law, Article 44, Item 1.
(Building restrictions within a road)
- G-2. (1) Buildings under the ground
(2) Buildings necessary for public welfare and not obstructing traffic, such as public comfort stations and police boxes
- G-3. Law, Article 44, Item 1 is exempted. (Refer to Chapter 3, Section II, (4) of this book.)
- H-1. Law, Article 47.
(Building restrictions by wall surface lines)
- H-2. Walls and pillars under ground.
- H-3. Law, Article 47. (Refer to Chapter 3, Section II, (5) of this book.)
- I-1. Law, Article 53, Item 4.
(The building-to-land ratio restriction)
- I-2. (1) Fireproof buildings within a fire protection district within neighborhood-commercial and commercial districts.
(2) Police boxes, public comfort stations, public pedestrian walkways.
(3) Buildings with no hazards in terms of safety, fire protection, and sanitation in parks, plazas, roads, rivers, etc.
- I-3. Law, Article 53. (Refer to Chapter 3, Section IV, (2) of this book.)
- J-1. Law, Article 54, Item 1.
(Ordinance, Article 135-5)
(Setback of outer walls of a house within Class 1 residential

- housing districts)
- J-2. (1) Outer walls with a gross length of 3 meters or less.
(2) Storage houses with eaves of a height of 2.3 meters or less and a gross floor space of 5 square meters or less.
- J-3. Law, Article 54, Item 1. (Refer to Chapter 3, Section IV, (3) of this book.)
- K-1. Law, Article 57, Item 2.
(Easing of height restrictions on a building within roads)
- K-2. Buildings within roads. (Except those under elevated roads.)
- K-3. Law, Article 59, Item 1, 1.
- L-1. Law, Article 59, Item 1.
(Restrictions on volume ratio, building-to-land ratio, and building area within high use districts)
- L-2. (1) Buildings easily transferable or removable such as those made of wood, steel-frame structures, or concrete blocks.
(However, only including those of two stories or less and without basements.)
(2) Buildings necessary for public welfare such as public comfort stations and police boxes.
- L-3. Law, Article 59, Item 1. (Refer to Chapter 3, Section IV, (1) and (2) of this book.)
- M-1. Law, Article 59, Item 2.
(Restrictions on the position of wall surfaces within high use districts)
- M-2. Underground walls and pillars.
- M-3. Law, Article 59, Item 2. (Refer to Chapter 3, Section IV, (8) of this book.)

(page 22)

N-1. Law, Article 60, Item 2.

(Restrictions on the position of wall surfaces within specified urban districts)

N-2. Underground walls and pillars.

N-3. Law, Article 60, Item 2.

O-1. Law, Article 60, Item 3.

(Exemptions from application for buildings within specified urban districts)

O-2. Buildings within specified urban districts.

O-3. All provisions of Law, Articles 52 through 59-2. (Refer to Chapter 3, Section IV, (8) of this book.)

P-1. Law, Article 61.

(Building restrictions within fire protective areas)

P-2. (1) Attached structures to one-level buildings whose outer walls and eave undersurfaces have a fire protective structure. (The gross floor space should be 50 square meters or less.)

(2) Buildings whose main structures are made of incombustible materials and with little possibility of fire occurring, such as wholesale marketplace sheds and mechanical manufacturing facilities.

(3) Gates or fences. (If a gate is higher than 2 meters, only those made of incombustible materials or covered with incombustible materials are exempted.)

P-3. Law, Article 61. (Refer to Chapter 3, Section V, (2) of this book.)

Q-1. Law, Article 62, Item 1.

(Building restrictions within semi-fire protective areas)

Q-2. The same as (2) in P-2.

Q-3. Law, Article 62, Item 1. (Refer to Chapter 3, Section V, (2) of this book.)

R-1. Law, Article 67-2.

(Exemption from application because of special materials or structural methods)

R-2. Buildings using special materials and structural methods not anticipated in the provisions of Chapter 3, Section 5 of the Building Standards Law (and other ordinances and regulations based on the Law) and approved by the Minister of Construction.

R-3. Among the provisions of Chapter 3, Section 5 of the Building Standards Law (and other ordinances and regulations based on the Law), unrelated and inappropriate provisions are exempted. (Refer to Chapter 2, Section I, (4) of this book.)

S-1. Law, Article 85, Item 1.

(Exemption from application to temporary buildings)

S-2. Buildings within areas declared emergency disaster areas and their adjoining areas by concerned government agencies with the approval of a prefectural governor and whose construction begins within one month of the disaster's occurrence.

(1) Emergency repair of destroyed buildings.

(2) Disaster assistance buildings built by central and local governments or the Red Cross. (Except those within fire protective areas.)

(3) Buildings built by disaster victims for their own use

and whose gross floor space is 30 square meters or less.

(Except those within fire protection areas.)

(The exemptions from application specified in (2) and (3) are valid for 3 months after completion of a building. If the concerned government agency approves, the maximum period of exemption is 2 years .

S-3. Exempted entirely.

(All provisions of the Building Standards Law and other ordinances and regulations based on the Law are exempted.)

(Refer to Chapter 4, Section VI of this book.)

(page 23)

T-1. Law, Article 85, Item 2.

(Exemption from application to temporary emergency disaster buildings and temporary buildings used for construction)

T-2. (1) Temporary emergency disaster buildings necessary for public welfare, such as stations, post offices, and government agency offices. (The duration of the exemption-from-application period is 3 months after completion of a building. The maximum length is 2 years if the concerned government agency approves.)

(2) Temporary buildings at construction sites, such as offices, preparatory work shelters, and storage places for construction materials. (The duration of the exemption-from-application period is, of course, the period required for completion of construction.)

T-3. Law, Article 19, 21 through 23, 26, 31, and 33; Article 34, Item 2; Article 35, 36, 37, 39, and 40, (and other ordinances and regulations related to Law, Articles 19, 21, 26, 31, 33,

and 35; Article 34, Item 2).

Law, Chapter 3. (The Law, Article 63 is applied to buildings whose gross floor area is less than 50 square meters within fire protective and semi-fire protective areas.) (Refer to Chapter 4, Section VI of this book.)

U-1. Law, Article 85, Item 4.

(Temporary buildings, such as temporary entertainment facilities, temporary stores, etc.)

U-2. (1) Temporary buildings, such as temporary entertainment facilities, exhibition and fair buildings, and temporary stores approved by concerned government agencies. (The duration of the exemption-from-application period is less than one year.)

(2) Temporary buildings, such as temporary stores necessary or substitutes during construction of a proper building and approved by concerned government agencies. (The duration of the exemption-from-application period is the period required for construction.)

U-3. Law, Articles 21 through 27, and 31; Article 34, Item 2; Articles 35-2 and 35-3. Law, Chapter 3, Sections 1 through 5. (Refer to Chapter 4, Section VI of this book.)

CHAPTER II

(page 24)

Chapter 2 Technical Standards to
Secure the Safety of Buildings

(The Building Code in the Building Standards Law)

SECTION I Securing the Safety of Buildings

I. (1) What Is the Safety of Buildings?

By definition a safe building generally should not harm the life, health, and property of a person who uses the building properly (including usage in accordance with social custom, which is a generally recognized assumption in designing). Therefore, in the event of collapse and damage due to unanticipated overload, natural disaster, or accidents, a building is not said to have been unsafe.

The specific dimensions of safety are roughly defined as follows.

(1) Safety in terms of structural durability

A building should not collapse, suffer damage, or be greatly deformed by its empty weight, loaded cargo weight, fallen snow, wind pressure, earth pressure, water pressure, earthquakes, or other vibrations and impacts.

(2) Fire prevention and fireproofing

A building should not collapse, suffer damage, or be greatly deformed in case of fire.

(3) Durability and weatherproofing

A building should not collapse, suffer damage, or be greatly deformed by corrosion, deterioration, and other forms

of degeneration.

(4) Safety in use and safety in evacuation

When in use, whether in normal times or in an emergency such as earthquakes, fire, or other disaster, a building should not cause harm to the lives or health of the people who use it (Specifically, this means falls due to slippery corridors and steps under normal conditions and accidents resulting in death and injury due to the inadequacy of escape ladders during an emergency).

(page 25)

(5) Preservation of good and sanitary environmental conditions

A building should protect people from unsanitary and other environmental conditions that affect people's health and possess a good indoor environment.

These specific definitions of safety have been changing both in quality and quantity as society, the economy, and scientific technology progress. They will surely change and be improved in the future.

What I want to mention in particular is that safety, even though backed up by the accumulation of scientific technology, is not a technical truth (but there are many people who think so).

For instance, in regard to the first dimension of safety mentioned above, it is possible to adopt a policy of emphasizing only the strength and unbreakability of a building. On one hand, such a policy may lead to an increase in structural durability (or increase in safety in the popular sense). On the other hand,

it causes the loss of economic balance (the relationship between the amount invested and the product). Therefore, if physical conditions adequate for prerequisite loads and external forces are appropriately materialized from the engineering standpoint, the building must be accepted as safe in the narrow sense. Let us suppose a building is strong enough to survive every severe earthquakes that might occur only once every several hundred years. The result of an enormous investment (the result of making the building stout enough to avoid all damage), is a building with many huge pillars and almost no floor space available for use. (Moreover, suppose that its physical life is less than 100 years.) No one would want to build such a building. As for the aforementioned second dimension of safety, if the definition were "absolutely not to cause a fire" or "even if live charcoal starts something burning, it will absolutely never set the building afire," even if possible from engineering standpoint, such a building would be impossible economically.

As for the other dimensions of safety (3 - 5), more or less the same circumstances exist.

In order to realize safety as technical requisites it is necessary to grasp qualitatively and quantitatively the loads, external forces, fire and other external conditions, and the characteristics of the disasters with which a building must cope. To meet this goal, however, we do not now have sufficient information on natural scientific forecasts or a sufficient stock of engineering technology. Consequently, it is true that there are many cases when matters are dictated by economy and custom.

As I have said, social and economic principles also help determine the general safety of a building. (page 26) The safety of a building required by the Building Standards Law is further narrowed.

The Building Standards Law is basically an administrative code that forces people to bear the burden of controls and to accept and tolerate discipline (an administrative code with enforcement power). As long as this is so, the substance of safety must be limited to minimum necessity for public welfare. Specifically, standards for safety place an emphasis on (1) prevention of large-scale and serious losses to the national economy and the bases for people's livelihoods stemming from the collapse and damage of buildings and (2) prevention of harm to many and unspecified people (in particular the third parties) in the event of disaster. In principle, more emphasis is placed on the prevention of harm to the lives and health of people rather than the prevention of property loss.

As for (1), when you see examples of large-scale natural disasters such as earthquakes in underdeveloped countries, you can understand the inevitability of this sort of control by law as an interest of the whole nation or a national mission. By the way, it is an inevitable reality that the more advanced a country is, the better the building code it has.

Also, to accomplish the purpose of the second dimension it is natural that there are some buildings whose usage and size are far more severely regulated than others. (Refer to the next section: What Is Safety in Special Buildings?)

2. (2) What Is Safety in Special Buildings?

Special buildings are defined in the Building Standards Law. (Law, Article 2, Item 2)

Special buildings are classified into the following four groups numbered (1) through (4). (These special buildings amount to approximately 10 percent of all construction starts every year.)

- (1) Buildings available for use by many and/or unspecified people.
- (2) Buildings which have greater fire risks or larger fire loads.
- (3) Consequently, in those buildings the possibility of harming lives, health, and property of people in normal times or during fire or other emergencies is great.
- (4) Environmental pollution, land price fluctuations, and other influences on the surroundings are great.

Therefore, in the case of special buildings it is necessary to add special conditions for structures and facilities (the building code) and to execute special regulations concerning site selection conditions (the zoning code). (page 27) Concerning structure and facilities, judging from recent examples of disasters and accidents, it is necessary to keep in mind that regulations on fire prevention and evacuation have been strengthened.

3. (3) Description of Standards (Form)

When writing the provisions of technical standards, there are, roughly speaking, two forms: performance standards and specification standards (or prescription standards).

The performance standard involves the composition of specific articles indicating required performance values such as those seen in Article 22-2, Item 2, 3; Article 32, Items 1 and 2; Article 107, Item 1; and Article 108 of the present Building Standards Law Enforcement Ordinance.

The characteristic of this form is that a provision does not question the specific methods employed as long as a building satisfies all performance values. This form has the flexibility to respond quickly to the progress and diversification of technology. However, unless discriminating standards for methods of testing and evaluating performance have been established and made widely known, this performance standards have the demerit of being difficult to apply in practice. (For this reason, Construction Ministerial Notifications and such have set up testing as well as designation and certification methods for fire preventive materials, fireproof and fire protective structures, fire preventive doors, and soundproof structures. Along with these, it is well-known that the specification standards described hereafter are in one sense separate supplements.)

The provisions of a specification standards specifically describe styles, materials, and dimensions. Consequently, they have the merit of being easily understandable by all and of causing less confusion. On the other hand, they are not flexible enough to allow legal approval of a material or structure that possesses performance equal to or better than the one specified in the provisions. As a result, they have the demerit of obstructing the practical application of newly developed technologies.

60

The trend in the future will be, no doubt, toward unification of performance standards. In order to do so, a special effort must be made to improve and spread widely discriminating standards.

Furthermore, from the aspect of enforcement of the present Building Standards Law, performance standards have a problem in relation to the institution of building certification by building directorates. In other words, as long as building certification is a binding action (A restricting action mechanically checks materials, structures, et cetera against the standards contained in the provisions and issues an approval or rejection. In essence, there must be no room for discretion.), the descriptive provisions must conform to the requirements of restricting actions. Consequently, descriptions of technical standards must leave no room for discretion and must not confuse. They demand articles that are exact and precise. As a result, it is necessary to keep in mind that descriptive provisions inevitably tend to assume form of specification standards.

(page 28) At the basic level, we must remember knowledgable people believe that arbitrary judgements by the responsible engineers at each stage of design, construction, and maintenance and management result in damage to the interests of the general public.

4. (4) Standards and the Attitudes of Engineers

Let me say something about how engineers should consider and handle technical standards in their practical work.

Let us take the case of design as an example. One of the worst attitudes of architects has long been, when specifically

engaged in design, to try to fit figures and forms to the provisions from beginning to end and not to give any attention to the intentions and purposes of the provisions at all. For instance, a provision says, "to set up a fire prevention district every 1,500 square meters or less." One attitude in drafting a specific surface utilization plan is to divide an area uniformly by 1,500 square meters without considering the purposes and functions of fire prevention districts or their actual effectiveness in the localization of a fire or providing a path for evacuation. There are many cases when an area may require districts of 500 square meters or 1,000 square meters to attain actual effectiveness. If as the result of sufficient consideration for the purposes, intentions, and practical effectiveness of provisions some formal figures do not conform to the provisions, we should depend on the exceptions specified in the provisions.

For this purpose, many provisions contain grounds for exceptions such as the ones with provisos. Moreover, as an exceptional provision, the Building Standards Law provides Article 38 that is applicable to Chapter 2 of the Law (the building code). (In the same sense, the Law provides Article 67-2 that is applicable to Chapter 3, Section 5 of the Law [regulations of fire prevention districts in the zoning code_7].)

When legislated, Article 38 was highly praised by law specialists as a technical code provision to promote progress and development of technology and its practical application and as a unique provision in terms of legislative theory. Recently,

many of structural planning methods for highrise buildings, prefabricated houses, new part materials, new construction materials, and fire prevention and evacuation facilities planning have been realized or used owing to these articles providing for exceptions. The number of cases to which the provisions for exceptions apply has been increasing greatly.

(page 29)

SECTION II Buildings and Sites

I. (1) Sanitation and Safety of Sites (Law, Article 19)

Sites for buildings must be formed in such a way that it is possible to maintain good sanitary conditions for the buildings and to secure the safety of buildings.

In principle, a lot must be higher than the boundary (not the center line) of the abutting road. The ground on which a building is to be built must be higher than surrounding ground. By virtue of this provision, a site's drainage line is assured, and dampness can be prevented in the building. (A road, as used here, means a road in general concept, which is a broader usage than a road as defined in Law, Article 42.) (Law, Article 19, Item 1)

As for reclaimed land, low level and damp land, and soft land or land with a possible risk of flood, measures to improve and raise the ground, such as banking (levee raising), are required in order to improve sanitary conditions. At the same time measures such as strengthening of pedestals to prevent irregular subsidence are required in order to secure safety in terms of structural durability. (Law, Article 19, Item 2)

These provisions are important not only in terms of routine sanitary conditions and safety but also because buildings on soft ground suffer more when earthquakes occur.

In addition to improvement of the site and the strengthening of building pedestals and groundwork, sites, needless to say, are required to be equipped for drainage of rain water and sewage pipes and ditches to drain the water used in everyday life. (Law, Article 19, Item 3)

Specific standards for drainage facilities are provided in Ordinance, Article 129-2, Items 1 and 3. Moreover, detailed regulations have been decided by the Minister of Construction in 1975 Construction Ministerial Notification No. 1597.

Concerning lots on sloped land or beneath cliffs, builders are required to take measures to ease grades or to establish retaining walls. Of course, it is necessary to avoid the choice of sites in steep hills and beneath steep cliffs where there is a possible risk of landslides or the crumbling of mountainsides (washouts) too great to be coped with on the individual site. As for this matter, many local governments regulate selection of sites in their ordinances and regulations. (Law, Article 19, Item 4; Law, Article 40)

In regard to housing site preparatory construction such as leveling ground, raising ground, and establishment of retaining walls, the Housing Sites Preparation Control Law provides technical standards for execution of housing site preparations.

(pp 66 - 75 of Translation missing)
(pp. 30 - 34 of Text missing)

as hardness in order to prevent a building from being destroyed.

Table and Figure 7
Arrangement of Walls

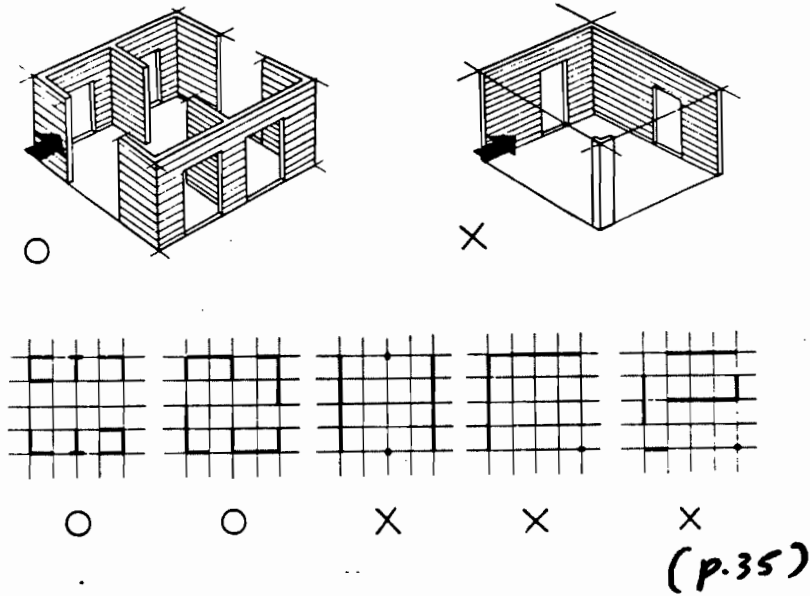

2. (2) Structural Parts and Materials

The requirements for structural parts and materials apply whether structural calculations are necessary or not. (However, if safety is verified by structural calculations, there are some cases when the requirements are exempted.) (Ordinance, Articles 37 through 39-2)

(1) Durability of structural parts and materials

Primary parts in terms of structural durability are required to be protected against corrosion, deterioration, wear and tear, etc. (Ordinance, Article 37) (Rustproofing of steel materials, preservation of timber against decay, and anti-wear measures for stairways are particularly important.)

(page 36)
(2) Pedestals

A pedestal must transfer load and external forces that affect a building safely to the ground. (In other words, it should transfer load and external forces to the ground without causing inclination or fall.) Moreover, a pedestal should be sufficiently safe against subsidence or deformation of the ground. In particular, we must pay attention to irregular subsidence of ground and subsequent damage to a building.

We have not obtained sufficient technical knowledge concerning pedestals (and the nature of the soil). Consequently, combined use of various kinds of pedestals is banned and the mandatory requirement of bearing piles for a large-scale buildings are provided in Article 38 of the Building Standards Law Enforcement Ordinance. Also, in order to protect a pile from damage while constructing a pedestal with piles, a pile is required to possess a certain strength. Moreover, in case of wooden piles, they must be installed beneath the level of constant water. (Ordinance, Article 38)

Table and Figure 8
Examples of Methods to Prevent Irregular
Subsidence of a Pedestal

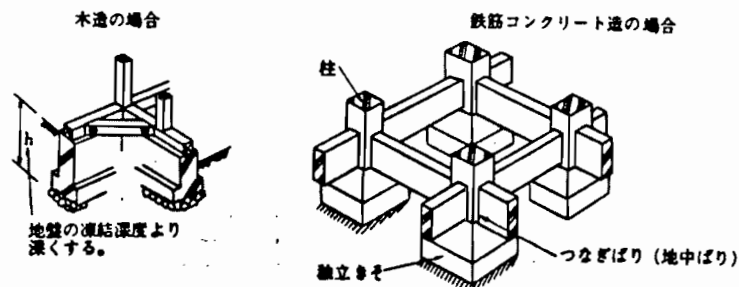

66

Keys

1. The case of wooden structures
2. Deeper than the freezing depth of ground
3. The case of concrete structures
4. Pillar
5. Independent pedestal
6. Tie beam (underground beam)

Table and Figure 9
Buildings Required to Have Bearing Piles
(Ordinance, Article 38, Item 3)

建 築 物 の 規 模	建築物に作用する荷重/ 最下階の床面積
(イ) 高さ>13m	10t/ m ²
(ロ) 延べ面積>3000m ²	

Keys

1. Size of building
2. Load affecting a building/floor area of the bottom floor
3. Height is taller than 13 meters.
4. Gross floor area is larger than 3,000 square meters.
(page 37)

Table and Figure 10

Prohibition of Combined Use of Various Kinds of Pedestals
(Ordinance, Article 38, Item 2)

(The difference in bearing conditions between various kinds of pedestals causes irregular subsidence.)

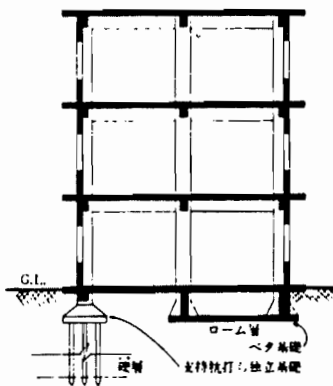

Keys

- 1. Loam layer
- 2. Solid pedestal
- 3. Independent pedestal with bearing piles
- 4. Conglomerate layer

Table and Figure 11
 Position of Wooden Piles
 (Ordinance, Article 38, Item 5)

(P.37)

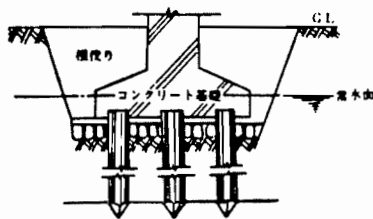

Keys

- 1. Pit excavation
- 2. Concrete pedestal
- 3. Constant water level

Table and Figure 12

Pedestals with Piles and Subsidence of Ground

When ground subsides because of a lowering of the level of underground water or some other reason, a building supported by bearing piles begin to stand out above the surrounding ground. (Some of the buildings in Uchisaiwaichō and around Hibiya in pre-World War II Tokyo were such examples.) In some cases, as shown in (2), piles may be broken by the force of friction with subsiding soil. (Since this friction force is exerted in the reverse direction of the friction force of ordinary friction piles, it is called negative friction.)

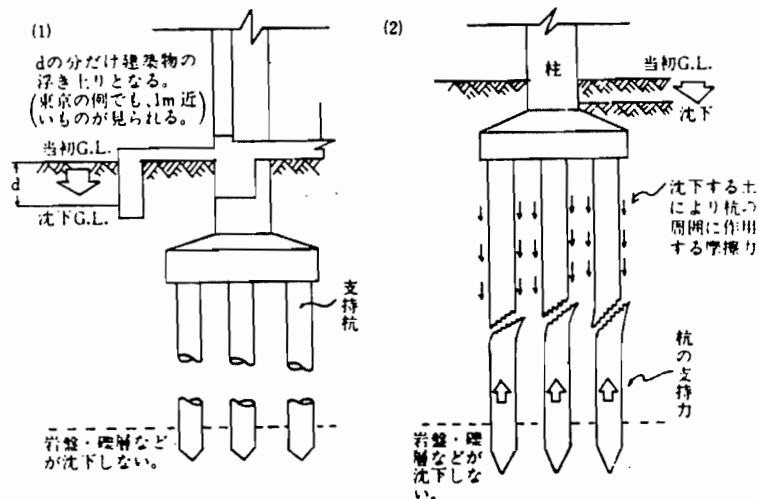

Keys

1. A building stands out by a height of "d." (Heights of "d" approaching 1 meter can be seen in Tokyo.)
2. Original ground level

3. Subsided ground level
4. Bearing pile
5. Rock beds and conglomerate layers that do not subside.
6. Friction force of subsiding soil that effects a pile.
7. Pillar
8. Bearing force of a pile

(page 38)

- (3) Connection of roof covering materials, hanging walls, and advertising signs

Although they are not primary parts in terms of structural durability, installed materials such as roof covering materials (roof tiles), interior finish materials, exterior finish materials, and hanging walls and advertisement and decoration towers must be firmly connected so as to not fall apart in the face of wind pressure, earthquakes, and other vibrations and impacts (including those arising from use of a building). People inside and outside of a building could be harmed if they fall apart. (Ordinance, Article 39)

Concerning roof covering materials, exterior finish materials, and outside-facing hanging walls, 1971 Construction Ministerial Notification No. 109, based on Article 39, Item 2, of the Building Standards Law Enforcement Ordinance provides detailed standards for installation methods, structural calculation methods, the relation between size and thickness of glass, the permissible displacement between stories, etc. (Refer to Tables and Figures 13 through 19.)

In particular, outside-facing hanging walls of a building with 3 or more stories above ground require:

1. Fastening to primary parts in terms of structural durability in order to prevent detachment;
2. Application of movable bearing structures to upper and lower parts in hanging PC wallboard;
3. A specified quality of lath sheet, wire lath, or metal lath in steel mesh lath mortar plastered hanging walls and measures to connect them to the groundwork; and
4. A rule banning use of a sealing agent with hardening tendency in fixed sash doors using glass other than wire mesh reinforced glass.

Moreover, as for outside-facing hanging walls (except portions below 31 meters that are not affected by the upper part in terms of structural durability), there is a rule that requires them not to fall apart under displacement between stories of 1/150. In addition, standards listed in Tables and Figures 14 and 15 apply. (1971 Construction Ministerial Notification No. 109; the latest revision is in 1978 Construction Ministerial Notification No. 1622.)

(4) Water tanks and smokestacks protruding from roof tops

As observed in actual examples of earthquake-struck buildings, it is clear that a considerable earthquake force affects water tanks and smokestacks protruding from roof tops. Measures against wind pressure are also important. For this reason, they are required to maintain safety in terms of structural durability by meeting standards decided by the Minister of Construction (Construction Ministerial Notification) separately from the structural calculations of a building

as a whole.

(Roughly, standards require them to be durable enough not to cause any damage, detachment, or falling down of a part fixed to the main body of a building, supporting bodies of a water tank, or trunk of smokestacks against horizontal force equivalent to a horizontal magnitude of approximately 1.0.)

(page 39)

Table and Figure 13

Wind Pressure Force That Affects Roof Covering Materials
(1971 Construction Ministerial Notification No. 109)

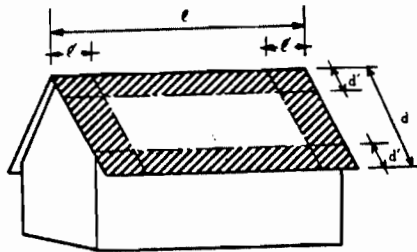

(p.39)

Keys

1. ("l" is $l/10$ and equal to 3 meters or less.)
("d" is $d/10$ and equal to 3 meters or less.)
2. Wind pressure force \geq velocity pressure (q) x wind force coefficient

The wind force coefficient is a numeric value indicated in Ordinance, Article 87, Item 4. However, the negative wind force coefficient for the part indicated by  is supposed to be 1.5.

$$3. q \text{ kg/m}^2 = 120 \frac{4}{h}$$

"h" is the height (in meters) from the ground level to each

location of roof covering materials.

Table and Figure 14

Wind Pressure Force That Affects Outside-Facing Hanging Walls (in the case of buildings taller than 31 meters)
(Construction Ministerial Notification No. 109)

風 圧 力		≧速度圧 (q) × 風力係数	
速度 圧	h < 16m の場合	q kg/m ² = 60√h	hは、その帳壁の高さ (m)。
	h ≧ 16m の場合	q kg/m ² = 120√h	hは、その帳壁の高さ (m)。
一般の場合は、令87条4項による。ただし、閉鎖型建築物の次の部分は、以下のとおりとする。			
風 力	正風圧作用壁面(風上側)	0.1 < $\frac{l}{H} \leq 0.2$ の場合	1.0
		0.2 < $\frac{l}{H} \leq 0.4$ の場合	0.9
		0.4 < $\frac{l}{H}$ の場合	0.8
係 数	負風圧作用壁面(風下側) のうち、  の部分	0.1 < $\frac{l}{H} \leq 0.2$ の場合	H' = $\frac{H}{15}$ l' = $\frac{l}{6}$
		0.2 < $\frac{l}{H} \leq 0.4$ の場合	H' = $\frac{H}{10}$ l' = $\frac{l}{8}$
		0.4 < $\frac{l}{H}$ の場合	H' = $\frac{H}{6}$ l' = $\frac{l}{10}$

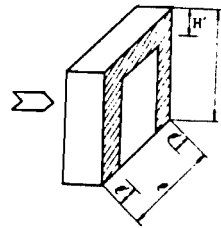
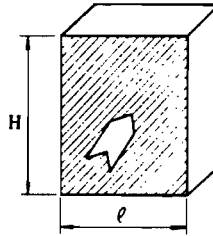

Keys

1. Wind pressure force
2. ≧ Velocity pressure (q) x wind force coefficient
3. Velocity pressure
4. Case where "h" is shorter than 16 meters
5. "h" is for the height (in meters) of a hanging wall
6. Case where "h" is equal to 16 meters or taller
7. Wind force coefficient
8. In general cases, follow values indicated in Ordinance, Article

87, Item 4. But, as for the following parts of closed type buildings, wind force coefficients are as follows.

- 9. Wall surface positively effected by wind pressure (the windward side)
- 10. A portion indicated by  of a wall surface negatively effected by wind pressure (the leeward side)
- 11. Case where $0.1 < \frac{l}{H} < 0.2$
- 12. Case where $0.2 < \frac{l}{H} \leq 0.4$
- 13. Case where $0.4 < \frac{l}{H}$

(page 40)

Table and Figure 15

Relationship of Size and Thickness of Glass Used for Outside-Facing Hanging Walls (in the case of buildings with heights exceeding 31 meters)

(Ordinance, Article 39, Item 2; 1971 Construction Ministerial Notification No. 109)

1枚のガラスの見付面積 $\leq \frac{30a}{P} \left(t + \frac{t^2}{4} \right)$
 注：Pは、ガラスに作用する風圧力 (kg/m²)
 tは、ガラスの厚さ(合わせ・複層ガラスの場合は、最も薄いものの厚さ) (mm)
 aは、下表の数値

ガラスの種類	普通板ガラス	みがき板ガラス	フロート板ガラス	
			厚さ ≤ 6mm	6mm < 厚さ
a	1.0	0.8	1.0	0.8
強化ガラス	網入みがき板ガラス	網入型板ガラス	平行線入りガラス	合わせガラス
	3.0	0.7	0.5	0.7
複層ガラス	型板ガラス	色焼付ガラス		
	1.5	0.6	2.0	

Keys

1. Surface area of a sheet of glass is equal to or less than $\frac{30a}{P}(t + \frac{t^2}{4})$.
2. Note: "P" is for wind pressure force that affects glass (kg/m²). "t" is for thickness of a sheet of glass. (In case of double glass or multilayer glass, "t" is for the thickness of the thinnest sheet of glass [mm].) "a" is for numeric values indicated in the table below.
3. Kind of glass
4. Ordinary flat glass
5. Polished flat glass
6. Float flat glass
7. Thickness
8. Tempered glass
9. Wire mesh reinforced polished flat glass
10. Wire mesh type flat glass
11. Parallel wire line reinforced glass
12. Double glass
13. Multilayer glass
14. Figured glass
15. Colored glass

Table and Figure 16
An Example of Roof Tile Binding

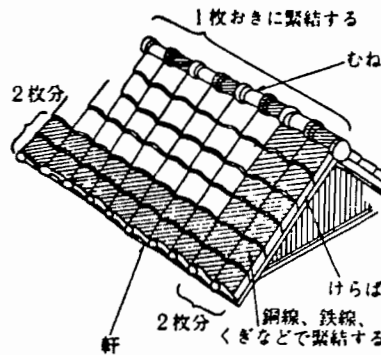

Keys

1. To bind every second one
 2. Ridgepole
 3. Two tiles
 4. Eaves
 5. Border of gable
 6. To bind with copper wire, steel wire, nails, etc.
- (page 41)

Table and Figure 17
Examples of Ornamental Stone and Terra Cotta Binding

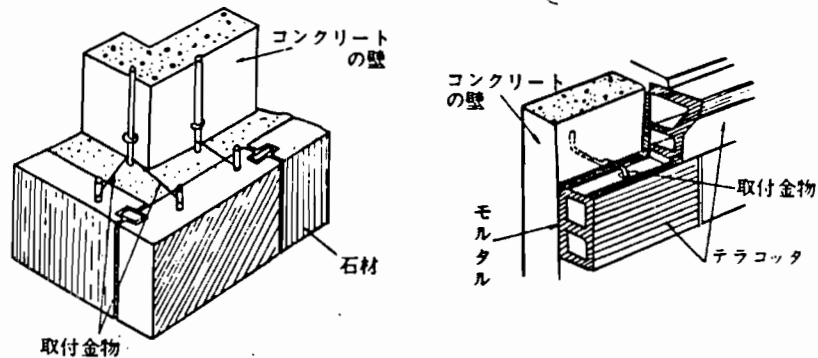

Keys

1. Concrete wall
2. Stone material
3. Fitting metal
4. Mortar
5. Terra cotta

Table and Figure 18
 An Example of Hanging Wall Binding
 (Refer to Ordinance, Article 62-7)

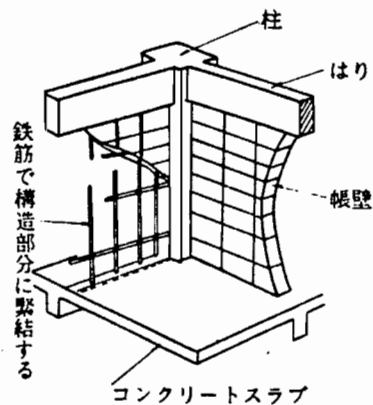

Keys

1. Pillar
2. Beam
3. Hanging wall
4. To bind to a structural part with steel reinforced rods
5. Concrete slab

Table and Figure 19
An Example of Curtain Wall Binding

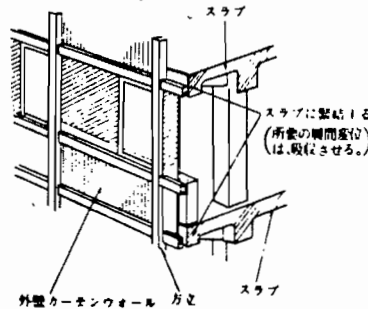

Keys

1. Slab
 2. To bind to slab (Let needed displacement between stories be absorbed.)
 3. Outer wall curtain wall
 4. A thick board or pillar for installation of a door or window
- (Tables and Figures 16 through 19 are related to Ordinance, Article 39, Item 2 and 1971 Construction Ministerial Notification No. 109.)

3. (3) General Structural Standards

General structural standards have been set up for each kind of structure of categories (1) through (8). They are technical standards necessary to secure structural safety in accordance with characteristics of each kind of structure. The standards are based on technical knowledge and views acquired through structural calculations and structural experiments as well as historically accumulated experiences.

As mentioned in (1) and (2), general structural standards apply to both types of buildings regardless of whether or not a structural calculation is required. (However, some of the standards allow for exceptional cases when safety is verified by structural calculations.)

When two or more kinds of structures are combined to construct a building, appropriate standards for each kind of structure listed in (1) through (8) apply to each corresponding part of the building.

(1) Wooden structure

The Ordinance provides standards for materials, structural parts such as pillars, diagonal beams, and axis joints, as well as joint connections and decayproof treatment. As a special case, it provides detailed standards for school buildings. Recently, standards for a rational structural method called platform frame construction, or the two-by-four construction method of North America, have been established in the Ordinance. The outline of the standards is described later in (G). (Ordinance, Articles 40 through 49) (The standards do not apply to "buildings of tea-ceremony houses and arbors" and "storages and barns with a gross floor area of 10 square meters or less."

(a) Timber

The timber used for structural parts should not have any defects affecting structural durability such as knots, decay, damaged surfaces, etc. (Ordinance, Article 41)

(b) Foundations and pedestals

As a rule, a foundation must be set up under pillars of the bottom floor and the foundation must be connected to the surface of a solid long rectangular concrete pedestal (within areas designated "Soft Ground Area" [Designated areas by Ordinance, Article 88, Item 2_7, a solid steel rod reinforced long rectangular concrete pedestal]).

(Ordinance, Article 42)

(page 43)

Table and Figure 20
 Cases without Foundations
 (Ordinance, Article 42, Item 1)

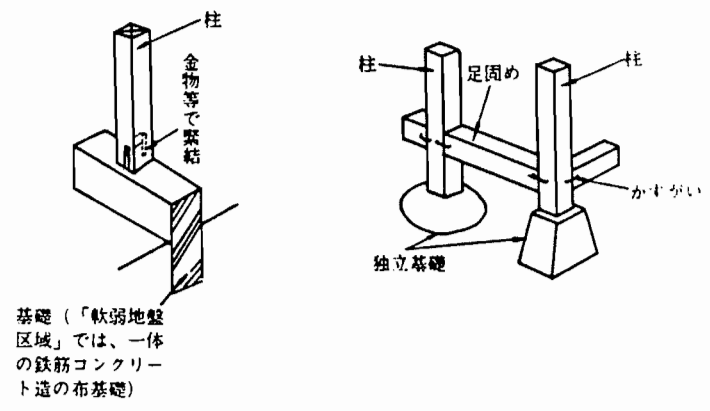

Keys

1. (A case where pillars are connected to a pedestal)
2. Pillar
3. Connect with metal
4. Pedestal (within areas designated "Soft Ground Area," a solid long rectangular reinforced concrete pedestal)
5. A case where an underfloor cross bar is used in one-story houses (except those in "Soft Ground Areas")

6. Underfloor cross bar
7. Clamp
8. Independent pedestal

Table and Figure 21
 Connection of Foundation and Pedestal
 (Ordinance, Article 42, Item 2)

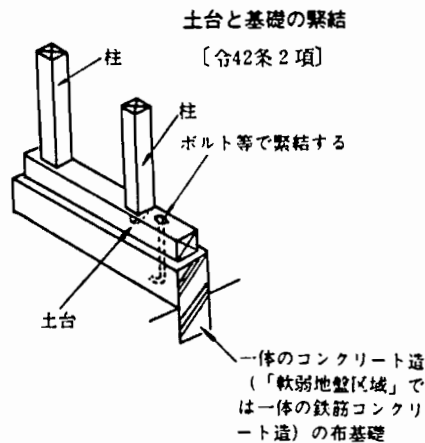

Keys

1. Pillar
2. Connect with a bolt
3. Foundation
4. Solid long rectangular concrete pedestal (a solid steel rod reinforced long rectangular concrete pedestal in "Soft Ground Areas")

(c) Minimum dimensions of a pillar

Concerning the size of a pillar, the minimum dimensions are provided in accordance with usage, number of stories, and the structure of a building. (Ordinance, Article 43)

The effective length-width ratio (the ratio of the buckling length to the smallest second degree constant

radius of cross section; refer to Table and Figure 43) of a primary pillar in terms of structural durability must be 150 or less. (Ordinance, Article 43)

Corner pillars and other pillars of equivalent importance in a building of 2 stories or more must be as a principle through pillars. (Ordinance, Article 43)

(page 44)

Table and Figure 22
Required Minimum Dimensions of a Pillar
(value of d/h or d'/h in each direction)
(Ordinance, Article 43)

建築物	柱		左欄以外のとき		
	(イ) l 又は l' が 10m 以上のとき (ロ) 学校、保育所、劇場、映画館、演芸場、観覧場、公会堂、集会場、店舗 (10m 以内のものを除く)、公衆浴場のとき	最上階又は平家建	2階建のときの1階 3階建のときの2、1階	最上階又は平家建	2階建のときの1階 3階建のときの2、1階
土蔵造などの壁の重量が特に大きい建築物		1/22	1/20	1/25	1/22
屋根がとくに軽い材料でよかれたもので上欄のものを除く建築物		1/30	1/25	1/33	1/30
上記の2欄にあてはまらない一般の建築物		1/25	1/22	1/30	1/28

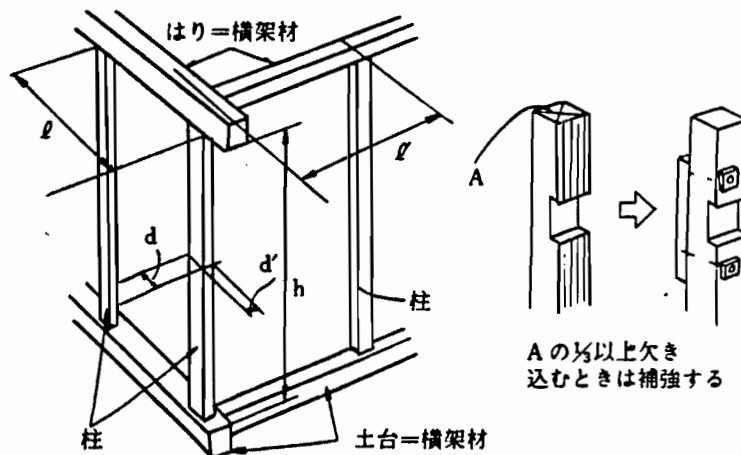

Keys

1. Pillar
2. Building
3. Buildings whose wall weight is exceptionally heavy, such as a godown-style house
4. Buildings whose roof is covered by very light-weight materials, except those described in 3.
5. Buildings other than 3 and 4.
6. (A) Cases where "l" or "l'" is 10 meters or more
(B) Cases of schools, day-care centers, theatres, movie theaters, entertainment halls, exhibition places, public halls, meeting places, stores (except those whose floor area is 10 square meters or less), and public bath houses.
7. The top floor or a one-story house
8. The first floor of a 2-story house and the first- and second-floors of 3-story house.
9. Others except those indicated in 6.
10. Calculation of minimum dimensions of a pillar.
11. Beam = cross mounting material
12. Foundation = cross mounting material
13. Pillar
14. When one third or more of the width of "A" is cut into, the part being cut into must be reinforced.

(page 45)

(d) Diagonal beam

The standard specifies the size of diagonal beam that must bear tensile and compressive forces. It also specifies that a part in the end of a diagonal beam close

to a connection must be reinforced by a bolt, clamp, or other metal and that, as a rule, prohibits cuts into a diagonal beam. (Ordinance, Article 45)

Table and Figure 23

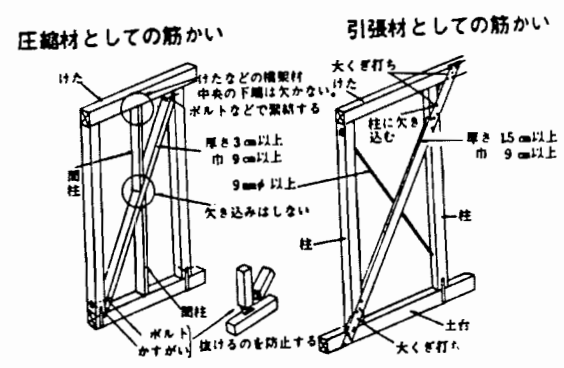

Keys

- A. Diagonal beams as compressive material
- B. Diagonal beams as tensile material
- 1. Crossbeam
- 2. Stud
- 3. Bolt
- 4. Clamp
- 5. To prevent from coming out
- 6. A central part of the underside of cross mounting materials such as a crossbeam should not be cut into.
- 7. Connect with a bolt
- 8. Thickness of 3 cm or more
- 9. Width of 9 cm or more
- 10. Not to be cut into
- 11. Drive in large nails
- 12. Cut into a pillar

- 13. Thickness of 15 cm or more and width of 9 cm or more
- 14. Diameter of 9 mm or more
- 15. Pillar
- 16. Foundation

(e) Axis joints required for structural durability

- a) In wooden buildings, axis joints must be installed in well-balanced manner to ensure safety against all horizontal forces (mainly earthquake force and wind pressure force). (Ordinance, Article 46)
- b) The corners of floor goundworks and tie beams must be reinforced by installing bracing materials and a roof truss must be reinforced by installing deflection stoppers. (Ordinance, Article 46) (Refer to Tables and Figures 24 and 25)

(page 46)

Table and Figure 24

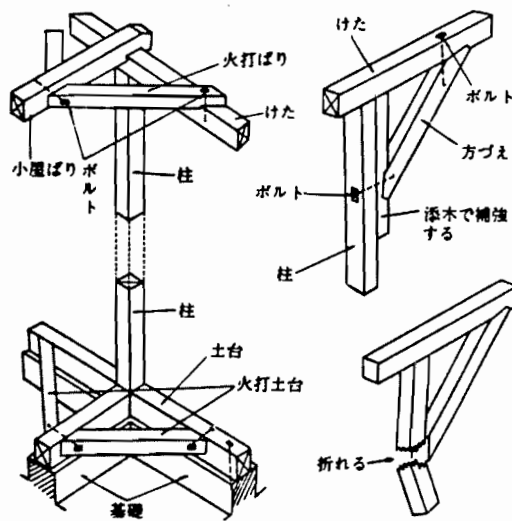

Keys

- 1. Bracing beam and others
- 2. Bracing beam
- 3. Crossbeam
- 4. Pillar
- 5. Tie beam
- 6. Bolt
- 7. Foundation
- 8. Bracing foundation
- 9. Pedestal
- 10. Reinforcement by angle braces
- 11. Angle brace
- 12. Reinforce with a splice plate
- 13. Broken

Table and Figure 25
Roof Truss

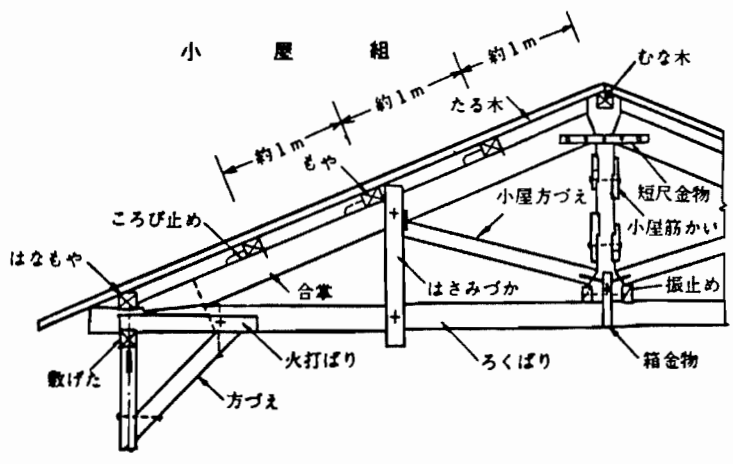

Keys

- 1. Approximately 1 meter

2. End purline
3. Cleat
4. Purline
5. Rafter
6. Ridgepole
7. Principal rafter
8. Inserting short support (queen post)
9. Roof angle brace
10. Strip metal
11. Roof strut
12. Deflection stopper
13. Upper plate
14. Angle brace
15. Bracing beam
16. Tie beam
17.  shaped metal

(page 47)

c) Length of an axis joint with strut

In the case of buildings with 2 stories or more or with gross floor areas exceeding 50 square meters, the ordinance requires installation of axis joints joining walls or struts mentioned in (a) of a length indicated in Tables and Figures 27 and 28 or longer. In particular, since light-weight roofing methods are often used, the consideration of wind factor indicated in Table and Figure 28 is important. The length of axis joints varies depending on the

kind of wall and strut. Therefore, the length is calculated by multiplying the actual length by a coefficient for each kind. (Ordinance, Article 46)
(Refer to Table and Figure 26)

Table and Figure 26

Kind and Coefficient of Axis Joints

(Ordinance, Article 46, Item 3; 1972 Construction Ministerial Notification No. 163)

軸組の種類		倍率
(軸組に設けた)壁	① 土塗壁	0.5
	② 木ずり等を打った壁 (片面のみ)	
	③ 木ずり等を打った壁 (両面)	1.0
(軸組に設けた)筋かい	④ 厚さ1.5cm×巾9cmの木材	1.0 (たすき掛け:2.0)
	⑤ 径9mmの鉄筋	
	⑥ 厚さ3cm×巾9cmの木材	1.5 (たすき掛け:3.0)
	⑦ 厚さ4.5cm×巾9cmの木材	2.0 (たすき掛け:4.0)
	⑧ 9cm角の木材	3.0 (たすき掛け:5.0)
併用	① ①-③の壁と④-⑧の筋かいの併用	それぞれの倍率の和 (たとえば、⑥と⑧の併用であれば、1.5)
⑨	その他、建設大臣が認定するもの	建設大臣認定値 (0.5~5.0)
参考1: 従前、法第38条に基づき建設大臣が認定した例(昭和47年建設省告示第163号)		
構造用合板を柱、間柱、胴縁、はり、けた、土台等の片面全面に打ち付けた壁を設けた軸組		倍率 2.5 ただし、同一の軸組部

合板は、JAS-1371適合品（外壁等は、特類に限定）分で、5mm厚以上（外壁等は7.5mm厚以上）とされているほか、釘の品質、打ち方、防錆措置などが建設省告示に定められている。

分での筋かいとの併用による倍率の合算は認められていない。

参考2：枠組壁工法（昭和52年建設省告示第1017号）における耐力壁の種類と倍率

耐 力 壁 の 種 類		倍 率
①	構造用合板（厚 ≥ 9 mm） ハードボード（厚 ≥ 7 mm） パーティクルボード（厚 ≥ 12 mm）	どれかを、片側全面打ち 3.0
②	構造用合板（ $9 >$ 厚 ≥ 7.5 mm） ハードボード（ $7 >$ 厚 ≥ 5 mm） 硬質木片セメント板（厚 ≥ 12 mm）	どれかを、片側全面打ち 2.5
③	フレキシブル板（厚 ≥ 6 mm） 石綿パライット板（厚 ≥ 12 mm） バルブセメント板（厚 ≥ 8 mm） 石綿けい酸カルシウム板（厚 ≥ 8 mm）	どれかを、片側全面打ち 2.0
④	石膏ボード（厚 ≥ 12 mm）を、片側全面打ち 製材（厚 ≥ 13 mm、幅 ≥ 21 cm）を、片側全面斜め打ち	1.5
⑤	シーリングボード（厚さ12mm） ラスシート（角波亜鉛鉄板：厚 ≥ 0.4 mm） （メタルラス：厚 ≥ 0.6 mm）	どれかを、片側全面打ち 1.0
⑥	製材（厚 ≥ 13 mm、幅 ≥ 21 cm）を、片側全面横打ち	0.5
⑦	上記①～⑥のいずれかと同等以上と、建設大臣が認定したもの （片側全面打ちのもの）	①～⑥のい ずれか（認 定倍率）
⑧	①～⑦のいずれかを、両側全面打ち	両側の倍率 の和。 （ただし、 5以下）
⑨	筋かい（厚さ ≥ 18 mm、幅 ≥ 89 mm）を、入れたもの	0.5
	①～⑧のいずれかと、⑨を併用したもの	それぞれの

⑩ 倍率の和。
（ただし、
5以下）

注：地震力に対して、必要な耐力壁の長さ（壁率）については、図表27（参考）を、
風圧力に対して、必要な耐力壁の長さ（壁率）については、図表28を、それぞれ
参照のこと。

Keys

1. Kind of axis joint
2. Coefficient
3. Wall (included in an axis joint)
 - 3-A. Mud plastered wall
 - 3-B. Wall with lath (one side only)
 - 3-C. Wall with lath (both sides)
4. Strut (included in an axis joint)
 - 4-D. Timber with a thickness of 1.5 cm and width of 9 cm
 - 4-E. Steel rod with a diameter of 9 mm
 - 4-F. Timber with a thickness of 3 cm and a width of 9 cm
 - 4-G. Timber with a thickness of 4.5 cm and a width of 9 cm
 - 4-H. Timber with a thickness of 9 cm and a width of 9 cm
5. (Placed crosswise : __)
6. Combined use
 - 6-I. Combined use of a wall from (A) through (C) with a strut from (D) through (G).
7. Total of their coefficients (For example: In case of combined use of (B) and (D), the coefficient is 1.5.)
- 8-J. Other kinds approved by the Minister of Construction
9. Value approved by the Minister of Construction
10. Reference: Cases approved by the Minister of Construction based on Law, Article 38. (1972 Construction Ministerial Notification No. 163)
11. An axis joint joining a wall with plywood nailed on the entire surface of one side of the pillars, studs, beams, girders, and foundation. The plywood used must meet JAS-

1371 (Plywood used for outer walls is limited to a special class.) and has a thickness of 5 mm or more (for outer walls, a thickness of 7.5 mm or more). In addition, the Construction Ministerial Notification specifies the quality of nails, the method of nailing, and decayproof measures.

12. The coefficient is 2.5. But, when used with a strut in the same axis joint, addition of the strut's coefficient is not approved.

(page 48)

A. Reference 2: Kind and coefficient of durable walls in a framework wall construction method (specified in 1977 Construction Ministerial Notification No. 1017)

B. Kind of durable wall

C. Coefficient

1. Either plywood for structural use with a thickness of 9 mm or more, hardboard with a thickness of 7 mm or more, particle board with a thickness of 12 mm or more is nailed on the entire surface of one side.
2. Either plywood for structural use thinner than 9 mm but equal to or thicker than 7.5 mm, hardboard thinner than 7 mm but equal to or thicker than 5 mm, or hard woodchip cement plate with a thickness of 12 mm or more is nailed on the entire surface of one side.
3. Either flexible plate with a thickness of 6 mm or more, asbestos pearlite plate with a thickness of 12 mm or more, pulp cement plate with a thickness of 8 mm or more, or asbestos calcium silicate plate with a thickness of 8 mm or more is nailed on the entire surface of one side.

- 4. Plaster board with a thickness of 12 mm or more is nailed on the entire surface of one side.
Lumber with a thickness of 13 mm or more and a width of 21 cm or more is diagonally nailed on the entire surface of one side.
- 5. Either sheathing board with a thickness of 12 mm or lath sheet (square wave galvanized iron plate with a thickness of 0.4 mm or more, or metal lath with a thickness of 0.6 mm or more) is nailed on the entire surface of one side.
- 6. Lumber with a thickness of 13 mm or more and a width of 21 cm or more is horizontally nailed on the entire surface of one side.
- 7. Those acknowledged by the Minister of Construction to be equal to or better than any of the items listed in 1 through 6.
(They must be nailed on the entire surface of one side.)
- 7-D. Any one of 1 through 6. (approved coefficient)
- 8. Any one of 1 through 7 is nailed on the entire surface of both sides.
- 8-E. The total of coefficients for both sides (but smaller than 5).
- 9. Those containing a strut with a thickness of 18 mm or more and a width of 89 mm or more.
- 10. Those combining any one of 1 through 8 with 9.
- 10-F. Total of their coefficients (but smaller than 5).
(page 49)
- G. Note: Concerning the length of a durable wall required (wall ratio) to cope with earthquake force and wind pressure force, refer to Tables and Figures 27 (Reference) and 28 respectively.

Table and Figure 27
 Minimum Length of an Axis Joint Required
 to Cope with Earthquake Force
 (Ordinance, Article 46, Item 3)

(Minimum required length of an axis joint per 1 square meter of floor area on one story)

建築物	階 地上階数1 の建築物	地上階数2の建築物		地上階数3の建築物		
		1階	2階	1階	2階	3階
下表の(一)又は(三)に掲げる建築物	15	33	21	50	39	24
下表の(二)に掲げる建築物	11	29	15	46	34	18

注：「軟弱地盤区域」（令88条2項指定区域）内では、それぞれの数値を1.5倍して適用。

- (一) 土蔵造の建築物その他これに類する壁の重量が特に大きい建築物
- (二) (一)に掲げる建築物以外の建築物で屋根を金属板、石板、石棉スレート、木板その他これらに類する軽い材料でふいたもの
- (三) (一)及び(二)に掲げる建築物以外の建築物

参考：枠組壁工法（昭和52年建設省告示第1017号）における地震力に対する耐力壁の長さ（倍率）の最低限

建築物	階	2階又は階数が1の建築物	階数（地階を除く）が2の建築物の1階
		cm/m ²	cm/m ²
①多雪区域外 （垂直最深積雪量<1m。 ②以外の区域。）	図表27の(二)に該当する屋根の建築物	12	21
	その他の屋根の建築物	15	24

②多雪区域内 （垂直最深積雪量≥1mで、特定行政庁が指定する区域。）	垂直最深積雪量dが、1m以上、2m以下	$15 \cdot d(m) + 15$	$15 \cdot d(m) + 25$
注：雪止めがなく、30度を超える勾配の屋根の建築物、雪おろしの慣習のある地方の建築物は、昭和52年建設省告示第1017号の表2を参照のこと。			

Keys

1. Story
2. Buildings of one story above ground
3. Buildings of two stories above ground
4. Buildings of three stories above ground
5. First floor
6. Second floor
7. Third floor
8. Buildings
9. Buildings described in (A) and (C) of the table below.
10. Buildings described in (B) of the table below.
11. Note: Within "Soft Ground Areas" (areas designated on the basis of Ordinance, Article 88, Item 2), multiply each value by 1.5 and apply.
 - A. Buildings whose wall weight is exceptionally heavy, such as buildings built in godown-style and other similar buildings.
 - B. Buildings other than those described in (A) and whose roof is covered by light-weight materials, such as metal plate, stone plate, asbestos slate, wooden plate, and other similar materials.
 - C. Buildings other than those described in (A) and (B).
12. Reference: Minimum length of a durable wall required to cope with earthquake force (coefficient) in a frame wall construction method (specified in 1977 Construction Ministerial Notification No. 1017).
13. Story
14. Second story or a building with one story.
15. First story of a building with two stories (except basement)
16. Buildings

- 17-(1) Outside of heavy snow fall areas (Maximum vertical depth of fallen snow is less than one meter. Areas other than 20-(2).)
18. Buildings whose roofs are covered with materials described in (B) of Table and Figure 27.
19. Buildings whose roofs are covered with materials other than those described in 18.
- (page 50)
- 20-(2) Within heavy snow fall areas (Areas where the maximum vertical depth of fallen snow is 1 meter or more and designated by a concerned government agency.)
21. Maximum vertical depth of fallen snow (d) is 1 meter or more but less than 2 meters.
22. Note: As for special provisions concerning buildings with a roof without roof guards, and whose slope exceeds 30 degrees, and buildings in regions where a custom of removing snow from the roof of a house exists, refer to Table 2 in 1977 Construction Ministerial Notification No. 1017.

Table and Figure 28

Minimum Length of an Axis Joint Required
to Cope with Wind Pressure Force

(Ordinance, Article 46, Item 3)

(Minimum required length of an axis joint per 1 square meter
of exposed area)

区 域	軸組の長さ cm/m ²
特定行政庁が規則で指定する区域 (「強風区域」)	$50 < (\text{特定行政庁が規則で定める数値}) \leq 75$
その他の区域	50

見付面積の算定方法

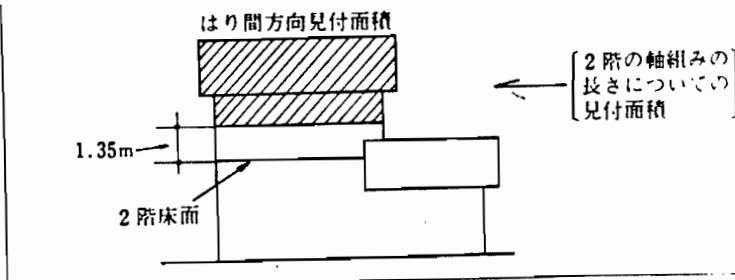
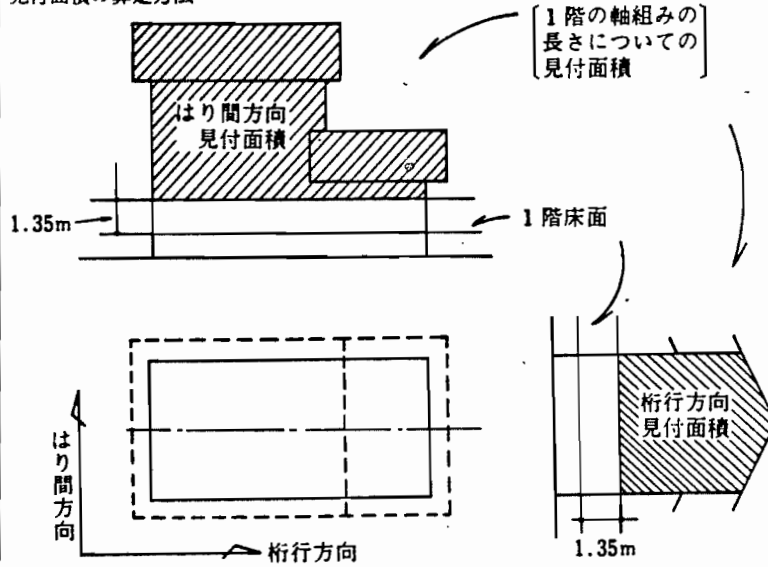

Keys

1. Area
2. Areas designated by regulations of the concerned government agency ("Strong Windy Areas")
3. Other areas
4. Length of an axis joint
5. A numeric value determined by regulations of the concerned government agency. It should be larger than 50 but equal to or smaller than 75.
6. Calculation method for exposed area
7. Exposed area for determining the length of an axis joint of first story
8. Exposed area in the direction of span
9. Floor surface of first story
10. Exposed area in the direction of beam length
11. Direction of span
12. Direction of beam length
(page 51)
13. Exposed area for determining the length of an axis joint of the second story
14. Floor surface of the second story

d) Joints and connections

Joints and connections that are primary parts in terms of structural durability must be tightly connected in a way such that stress from the existence of fastened bolts and clams and inserted pins can be transferred.

In the case of a connection of a pillar and

a large size beam, a connection of a wooden pillar and a steel frame beam, or where a localized stress harmful to a pillar occurs, a pillar must be reinforced with a splice plate.

In fastening a bolt, a metal washer of an appropriate size and thickness must be used.

(Ordinance, Article 47)

e) Decayproof measures

For a groundwork of plastering lath mortar and others that may supposedly cause decay in axis joints, decayproofing measures such as installation of waterproof paper must be taken.

Effective decayproofing measures and necessary termite and insect control measures must be taken for pillars, struts, and foundations within 1 meter of the ground. (Ordinance, Article 49)

Table and Figure 29
Decayproofing Treatment of Timber
(Ordinance, Article 49)

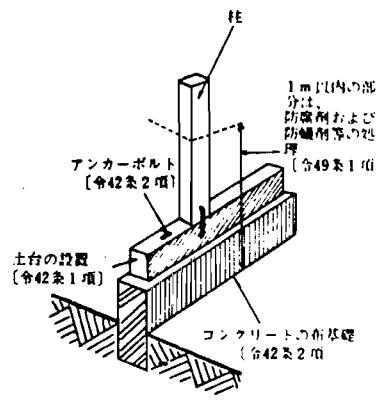

Keys

1. Pillar
2. Anchor bolt (Ordinance, Article 42, Item 2)
3. Installation of foundation (Ordinance, Article 42, Item 1)
4. For portions within 1 meter, decayproofing and termite and insect control measures are required. (Ordinance, Article 49, Item 1)
5. Long rectangular concrete pedestal (Ordinance, Article 42, Item 2)

(F) Wooden school buildings

A wooden school building must meet the standards described in the Japan Industrial Standard (JIS A 3301) decided by the Minister of Construction. Standards concerning axis joints in wooden school buildings other than those indicated in JIS have also been provided. (Ordinance, Article 48; 1970 Construction Ministerial Notification No. 1834)

(G) The frame wall construction method

The frame wall construction method is a typical structural method for wooden residential houses in North American countries such as the United States and Canada. It has been known in Japan as the two by four construction method (Two by four describes the cross-sectional dimensions of the primary type of lumber used.) or a platform frame construction method.

(page 52) Article 38 of the Building Standards Law has established standards for materials to be used, structural methods

such as joint and connection, decayproofing measures, et cetera in the frame wall construction method. As a result, among the provisions concerning wooden structures, provisions of Ordinance, Articles 41 through 47, and 49 (provisions on the axis joint construction method) do not apply to this method, as long as it follows Article 38 of the Law. (1977 Construction Ministerial Notification No. 1017)

The axis joint construction method, a traditional Japanese construction method, is composed of axis joints of pillars, beams, etc. On the other hand, one characteristic of the frame wall construction method is the use of very few kinds of standardized materials other than timbers whose cross sectional dimensions are two-by-four inches. It does not require complicated joints or connection processes. It usually relies on methods such as connecting one end to another, attachment to main parts, and laying one part on another mostly by nailing and using a few kinds of metal.

These parts and materials compose a framework for walls, floors, and roof trusses. In addition to the merits of rationality and speediness, the frame wall construction method is highly reliable in terms of strength. Only a few kinds and sizes of materials are used. Moreover, the number of steps in the construction procedure is small and productivity on the construction site is high. Compared with the axis joint construction method, it is said to be an epoch-making

method in various respects. On the other hand, as I have mentioned previously, it is highly dependent on connection by nailing. Therefore, especially strict standards have been provided concerning the quality of timber and nails and structural methods for the framework.

(a) In terms of structural durability materials for the framework and other materials that are used for primary parts must meet the standards indicated in Table and Figure 30.

(b) Structural methods

Briefly speaking, the basic procedure is to construct a framework for the floor on foundations which are anchored on long rectangular pedestals, and then to use it as a working floor to build and set upright the frameworks of the walls. In the case of a house with a second story, a framework for the second floor is also constructed. Head connectors are placed on tops of the wall sections. Then a rafter structure or a truss structure is placed on the head connectors. This completes the main structure.

Since the wall body itself is tightly sealed, through the use of insulation materials inside it is expected to possess good insulatability and dew condensation preventability.

101

(page 53)

Table and Figure 30

Qualities of Frame Materials and Other Materials Used for Primary Parts from the Perspective of Structural Durability in the Frame Wall Construction Method

(1977 Construction Ministerial Notification No. 1017)

区分	構造部材の種類	材料の種類	規格 (床材・壁材・屋根下地の区分については、構造耐力に係る規定に限る。)
枠組材	① 土台、床根太、端根太、側根太、まぐさ、天井根太、たるき、むなぎ		「枠組壁工法構造用製材規格」(日本農林規格、昭和49年農林省告示第600号)の甲種枠組材の特級・1級・2級 集成材の農林規格(昭和49年農林省告示第601号)の構造用集成材の1級・2級
	② 壁のたて枠・上枠、頭つなぎ		①の規格 「枠組壁工法構造用製材規格」の甲種枠組材の3級、又は乙種枠組材の(コンストラクションスタンダード)
	③ 壁の下枠		②の規格 「枠組壁工法構造用製材規格」の乙種枠組材のユティリティ
	④ 筋かい		製材の日本農林規格(昭和47年農林省告示第1892号)の針葉樹の製材・板類の特等・1等
床材・壁材・屋根下地	① 屋外に面する部分に用いる壁材 常時湿潤状態となるおそれのある部分に用いる壁材	構造用合板	「構造用合板規格」(日本農林規格、昭和51年農林省告示第894号)の特類
		ハードボード	JIS A 5904-1977 (硬質繊維板)の450又は350
		パーティクルボード	JIS A 5908-1977 (パーティクルボード)の200Iタイプ又は150Pタイプ
		硬質木片セメント板	JIS A 5417-1975 (木片セメント板)の0.9C
		フレキシブル板	JIS A 5403-1974 (石綿スレート)のフレキシブル板
		石綿パーライト板	JIS A 5413-1975 (石綿セメントパーライト板)の0.8-P又は0.8-P・A

(床材・壁材・屋根下地)		パルプセメント板	JIS A 5414-1974 (パルプセメント板)
		石綿けい酸カルシウム板	JIS A 5418-1973 (石綿セメントけい酸カルシウム板) の1.0-CK
		製材	(枠組材④筋かいの規格に同じ。)
		シーリングボード	JIS A 5905-1977 (シーリングボード) のシーリングインシュレーションボード
		ラスシート	JIS A 5524-1977 (ラスシート)
	② 上記①の部分以外の部分に用いる壁材	構造用合板	構造用合板規格の特類・1類
		その他の①欄の材料	①欄に同じ。
		石膏ボード	JIS A 6901-1975 (石こうボード)
	③ 床材又は屋根下地	構造用合板	②欄に同じ。
		パーティクルボード	①欄に同じ。
くぎ	くぎ	JIS A 5508-1975 (鉄丸くぎ)	
注：この表の規格に拘わらず、建設大臣の認定を受けた材料は、使用することができる。			

Keys

1. Section
2. Kind of structural parts and materials
3. Kind of material
4. Standard (As for the sections on floor materials, wall materials, and groundwork materials for roofs, only those standards related to structural durability apply.)
5. Frame materials
 - A-1. Foundation, floor baseboard, end baseboard, side baseboard, lintel, ceiling baseboard, rafter, ridgepole
6. Special, first, and second classes in "A" type frame materials specified in "Standards for Lumber for Structural Use in the Frame Wall Construction Method." (Japan Agricultural and Forestry Standards, 1974 Notification No. 600 of Ministry of Agriculture, Forestry, and Fisheries)
7. First and second classes in collected woods for structural use specified by Japan Agricultural and Forestry Standards for collected woods (1974 Notification No. 601 of Ministry of Agriculture, Forestry, and Fisheries)
- B-2. Vertical and upper frames of walls, head connectors
8. Standards for A- 1 (6 and 7) apply.
9. Third class in "A" type frame materials and "construction" and "standard" in "B" type frame materials specified in "Standards for Lumber for Structural Use in the Frame Wall Construction Method."
- C-3. Underframe of a wall
10. Standards for B-2 (8 and 9) apply.

11. "Utility" in "B" type frame materials specified in "Standards for Lumber for Structural Use in the Frame Wall Construction Method."
- D-4 Strut
12. Special and first classes in lumber and boards of coniferous trees specified by Japan Agricultural and Forestry Standards for lumber. (1972 Notification No. 1892 of the Ministry of Agriculture, Forestry, and Fisheries)
13. Floor materials, wall materials, groundwork materials for roofs
- E-1 Wall materials used for outside-facing walls.
Wall materials used for parts which may be constantly exposed to damp conditions.
14. Plywood for structural use
15. Special class specified in "Standards for Plywood for Structural Use." (Japan Agricultural and Forestry Standards, 1976 Notification No. 894 of the Ministry of Agriculture, Forestry, and Fisheries)
16. Hardboard
17. 450 or 350 (in hard fiberboard) specified in Japan Industrial Standards A 5904-1977.
18. Particle board
19. 200 P type or 150 P type (in particle board) specified in Japan Industrial Standards A 5908-1977.
20. Hard wood chip cement board
21. 0.9 C (in wood chip cement board) specified in Japan Industrial Standards A 5417-1975.

22. Flexible board
23. Flexible board (in asbestos slate) specified in Japan Industrial Standards A 5403-1974.
24. Asbestos pearlite board
25. 0.8-P or 0.8-P.A (in asbestos cement pearlite board) specified in Japan Industrial Standards A 5413-1975.
(page 54)
26. Pulp cement board
27. Japan Industrial Standards A 5414-1974. (Pulp cement board)
28. Asbestos calcium silicate board
29. 1.0-CK (in asbestos calcium silicate board) specified in Japan Industrial Standards A 5418-1973.
30. Lumber
31. Same as standards for struts for frame materials (12).
32. Sheathing board
33. Sheathing insulation board (in sheathing board) specified in Japan Industrial Standards A 5905-1977.
34. Lath sheet
35. Japan Industrial Standards A 5524-1977 (lath sheet).
- F-2. Wall materials used for parts other than those indicated in E-1.
36. Special and first classes specified in "Standards for Plywood for Structural Use."
37. Other materials described above except 14 (16, 18, 20, 22, 24, 26, 28, 30, 32, and 34).
38. Same as above (17, 19, 21, 23, 25, 27, 29, 31, 33, and 35).
39. Plaster board
40. Japan Industrial Standards A 6901-1975 (plaster board).

G-3. Floor materials and groundwork for roofs

41. Same as 36.

42. Same as 19.

43. Nails

44. Japan Industrial Standards A 5508-1975 (iron round nails).

45. Note: In addition to those described in this table, any materials that are approved by the Minister of Construction can be used.

Table and Figure 31
Structural Outline of the Frame Wall Construction Method

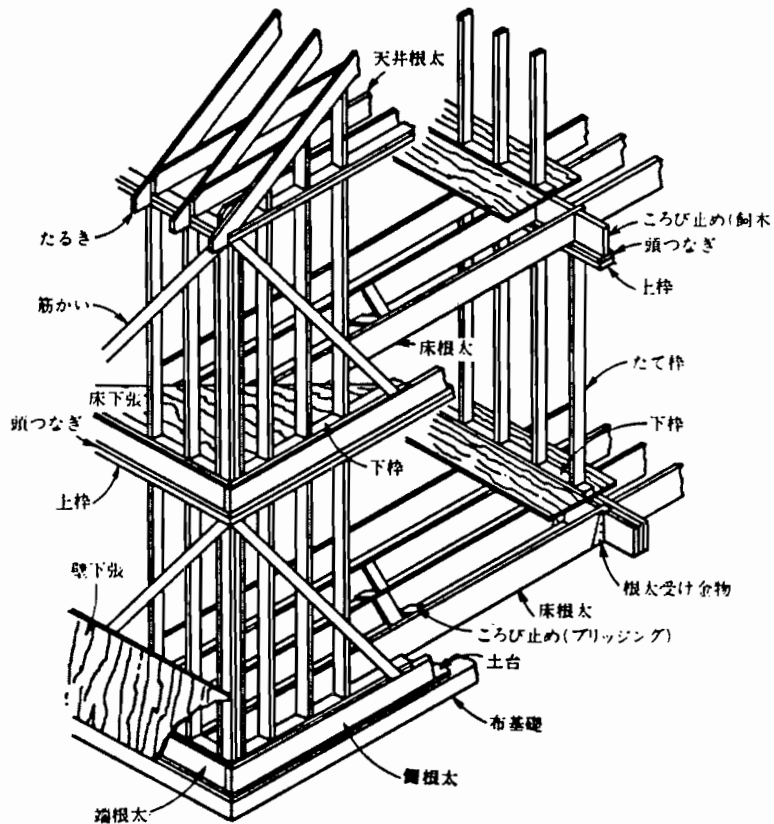

Keys

1. Rafter
 2. Strut
 3. Underlining of floor
 4. Head connector
 5. Upper frame
 6. Underlining of wall
 7. End baseboard
 8. Ceiling baseboard
 9. Floor baseboard
 10. Underframe
 11. Cleat (spacer)
 12. Vertical frame
 13. Baseboard holding metal
 14. Cleat (bridging)
 15. Foundation
 16. Long rectangular pedestal
 17. Side baseboard
- (page 56)

Table and Figure 32
Pedestal, Foundation, Floor, Wall

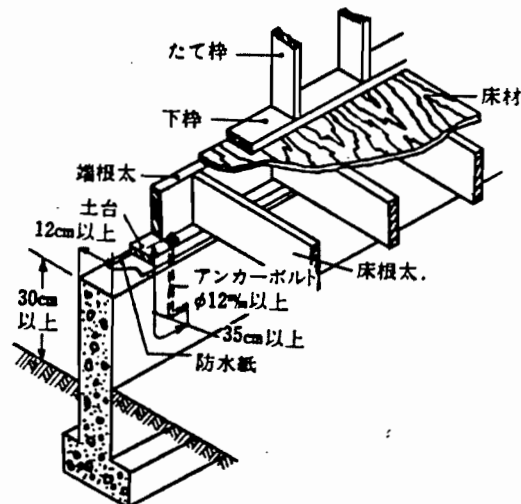

Keys

1. Vertical frame
2. Underframe
3. End baseboard
4. Foundation
5. 12 cm or more
6. 30 cm or more
7. Floor material
8. Floor baseboard
9. Anchor bolt
10. Diameter of 12 mm or more
11. 35 cm or more
12. Waterproof paper

Table and Figure 33
Framework of Floor

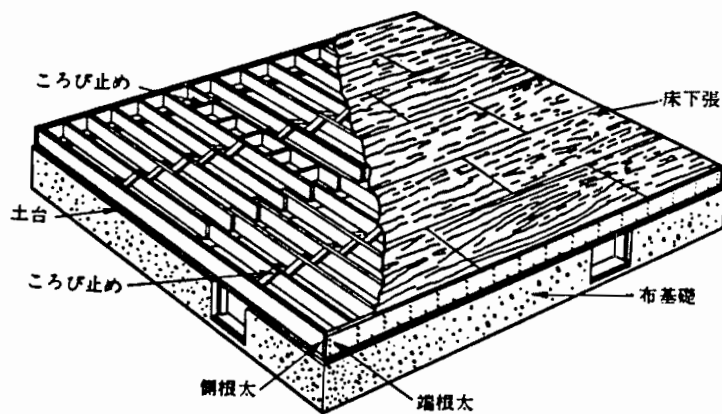

Keys

1. Cleat
2. Foundation

- 3. Side baseboard
 - 4. End baseboard
 - 5. Long rectangular pedestal
 - 6. Underlining of floor
- (page 57)

Table and Figure 34
 Framework of Wall

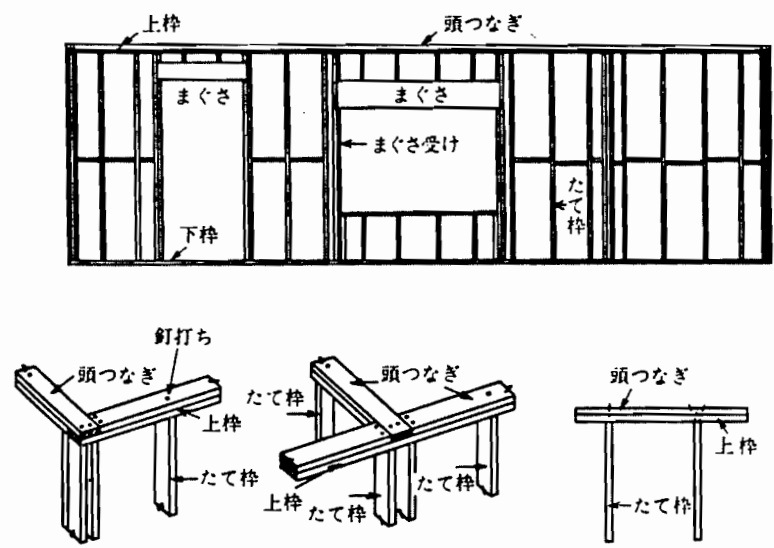

Keys

- 1. Upper frame
- 2. Head connector
- 3. Lintel
- 4. Lintel holder
- 5. Underframe
- 6. Vertical frame
- 7. Nailing

Table and Figure 35
Floor and Walls of Second Story

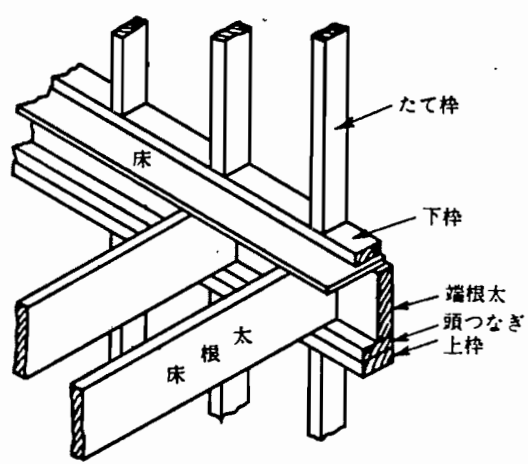

Keys

- 1. Floor
- 2. Floor baseboard
- 3. Vertical frame
- 4. Underframe
- 5. End baseboard
- 6. Head connector
- 7. Upper frame

(page 58)

Table and Figure 36
Rafter Joint for Roof

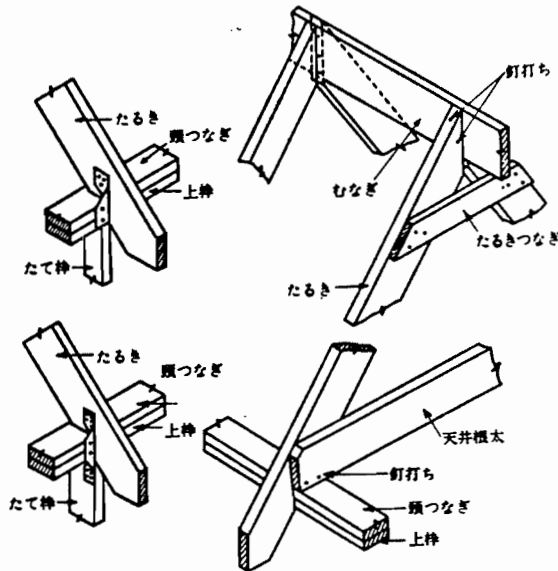

Keys

1. Rafter
2. Head connector
3. Upper frame
4. Vertical frame
5. Ridgepole
6. Nailing
7. Rafter connector
8. Ceiling baseboard

(2) Masonry structure

Masonry structure is a method of constructing buildings by bonding bricks, stones, or concrete blocks with mortar. Since many earthquakes occur in Japan, the provisions for masonry structure are relatively more severe than for other kinds of structure. These provisions do not apply to reinforced concrete-block structures (Ordinance, Articles 51 through 62). Article 55, Item 2 and Article 56 of the Ordinance do not apply to small-scale buildings (height is less than or equal to 4 meters and gross floor area is less than or equal to 20 square meters). Only the provisions of Articles 52, 53, and Article 55, Item 5 of the Ordinance apply to partition walls (of a height less than or equal to 2 meters) that are not a primary part in terms of structural durability.

(a) Since the construction of masonry structure greatly influences the durability of a constructed objects, it is important to thoroughly wash masonry materials. The provision also regulates the shape of joints, the mixture of mortar, and methods of filling in mortar (Ordinance, Article 52).

(b) Pedestals to bear walls of masonry structure must be either solid, long, rectangular reinforced concrete pedestals or solid, long, rectangular simple concrete pedestals (within "soft ground areas" designated on the basis of Ordinance, Article 88, Item 2, only solid, long, rectangular reinforced concrete pedestals). (Ordinance, Article 53)

113

(c) The length of a wall (the distance from one wall to the next wall) must be less than or equal to 10 meters (Ordinance, Article 54).

(d) The thickness of a wall is determined by the number of stories in a building, and the length and height of the wall. The thickness appropriate to each condition is shown in Table and Figure 37.

Table and Figure 37
 Thickness of Walls in Masonry Structures
 (Ordinance, Article 55)

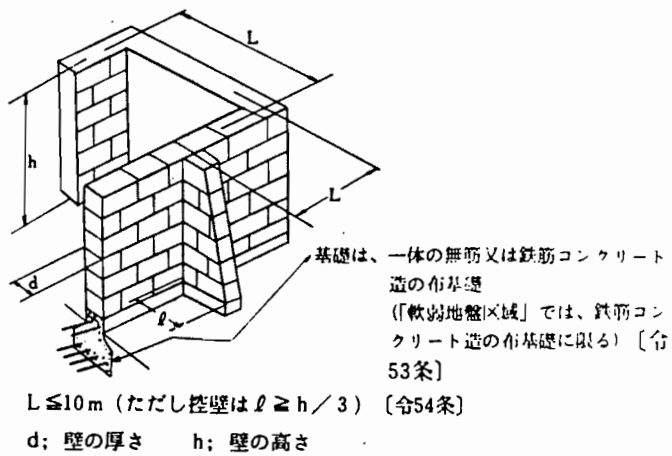

建築物	長さ	
	$L \leq 5\text{ m}$	$L > 5\text{ m}$
階数が2以上の建築物	d. $\geq 30\text{cm}$ かつ $\geq h / 15$ ($\geq 20\text{cm}$ ")	d. $\geq 40\text{cm}$ かつ $\geq h / 15$ ($\geq 30\text{cm}$ ")
平家建の建築物	d. $\geq 20\text{cm}$ かつ $\geq h / 15$ ($\geq 20\text{cm}$ ")	d. $\geq 30\text{cm}$ かつ $\geq h / 15$ ($\geq 20\text{cm}$ ")

Keys

1. Pedestals must be solid, long, rectangular reinforced concrete pedestals or solid, long, rectangular simple concrete pedestals (within "soft ground areas" solid, long, rectangular reinforced concrete pedestals only). (Ordinance, Article 53)
2. L is less than or equal to 10 meters (but the length of buttress "l" is greater than or equal to $h/3$). (Ordinance, Article 54)
3. "d" is the thickness of a wall.
4. "h" is the height of a wall.
5. Length
6. Buildings
7. Buildings of 2 stories or more.
8. Buildings of one story
9. And
10. Note 1. The values within parentheses indicate the length for a partition wall.
11. Note 2. In the case of double walls, the thickness of one of the walls must meet the standard.
12. Note 3. The wall must be thicker than the walls of the stories above.

(page 60)

(e) As a rule, steel or reinforced concrete frames must be placed on the top of walls (Ordinance, Article 56).

(f) When making an opening in a wall of a masonry structure, the length of a wall and the distance to other openings are regulated. Also, depending on the size and structure of an opening, certain reinforcement measures are

115

required around the opening (Ordinance, Article 57).

(g) When cutting a groove or flute in a wall, the depth and length of the groove or flute are regulated (Ordinance, Article 58).

(h) As a rule, handrails or handrail walls cannot be constructed in masonry structures (Ordinance, Article 60).

Table and Figure 38
Each Part of Masonry Structures
(Ordinance, Articles 56 through 58)

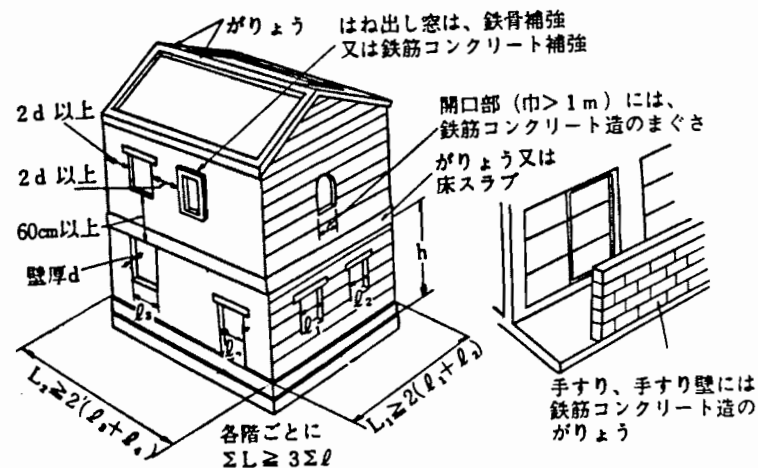

Keys

1. Frame
2. Greater than or equal to 2d.
3. Greater than or equal to 60 cm.
4. The thickness of a wall -- d
5. An overhang sash window must be reinforced with steel frame or reinforced concrete.
6. At an opening (whose width is greater than 1 meter), a

reinforced concrete lintel must be placed.

7. Frame or floor slab

8. For every floor ΣL is greater than or equal to $3\Sigma l$.

9. A reinforced concrete frame must be placed on the top of a handrail or handrail wall.

(i) Steel frame structures must be used for the framework for masonry structures. The parts in masonry structures must be firmly connected to the steel frame with metal (Ordinance, Article 59).

(j) Primary parts in terms of structural durability and other walls (of a height greater than or equal to 2 meters) made of masonry structure must not be supported by parts made of wood. In other words, primary parts and walls made of masonry structure should not be constructed on wooden pillars and beams (Ordinance, Article 62).

(page 61)

(k) As a special case, the provision is provided concerning the length and thickness of a fence made of masonry structures (Ordinance, Article 61).

Table and Figure 39
Masonry Structure Fences
(Ordinance, Article 61)

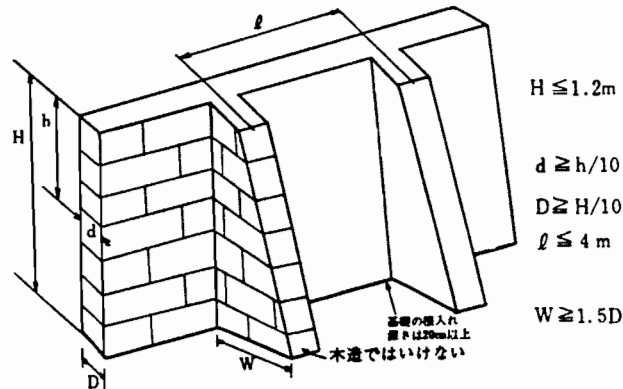

Keys

1. The legs of a foundation should be 20 cm or more under ground.
2. Should not be wooden structures.

3. (3) Reinforced concrete-block structures

These are structures of concrete blocks reinforced by steel rods. Ordinarily they are simply called block structures (Ordinance, Articles 62-2 through 62-8). For small-scale buildings (whose heights are less than or equal to 4 meters and whose gross floor areas are less than or equal to 20 square meters), only Ordinance, Articles 62-6 and 62-7 apply.

(a) Pedestals for reinforced concrete-block structures must be solid, long, rectangular reinforced concrete pedestals, except where reinforced concrete foundation beams are laid down (Ordinance, Article 62-3).

(b) As for durable walls, the length and thickness of a

wall and the area enclosed by durable walls are regulated.
 In particular, detailed regulations are provided concerning
 reinforcing rods (Ordinance, Article 62-4).
 (page 62)

Table and Figure 40
 Computation of Durable Walls
 (Ordinance, Article 62-4)

耐力壁の算定 [令62-4条]

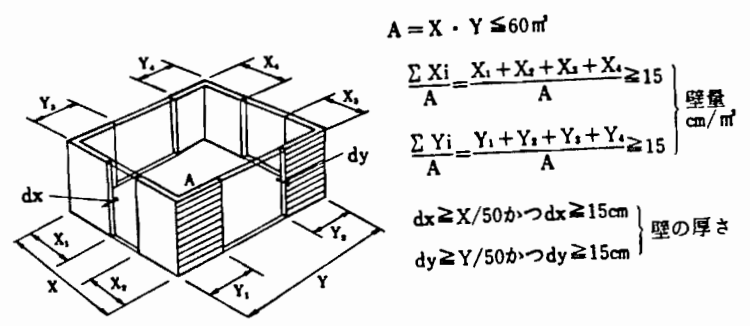

Keys

1. Mass of wall
2. Thickness of a wall
3. And

(c) As a rule, a reinforced concrete frame of a certain width must be placed on the top of the durable walls (Ordinance, Article 62-5).

(d) A sufficient amount of mortar must be filled in joints and hollow spaces. Vertical steel rods in durable walls, fences, and gates must not be connected inside the hollow space of a block, except in the case of connection by welding (Ordinance, Article 62-6).

(e) Hanging walls made of reinforced concrete structure in particular must be firmly connected to the structural parts

made of something other than wooden or masonry structures (Ordinance, Article 62-7).

Table and Figure 41
Each Part of a Reinforced Concrete-Block Structure
(Ordinance, Articles 62-3 through 62-6)

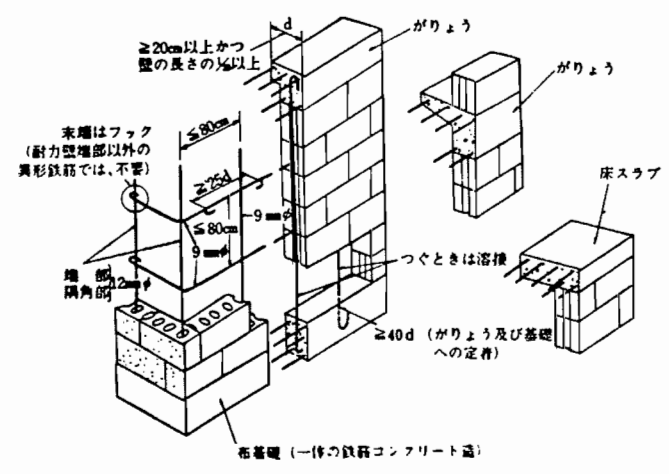

Keys

1. Greater than or equal to 20 cm and greater than or equal to 1/20 of the length of a wall.
2. Frame
3. The end must have a hook. (In the case of deformed bars used for other than the end of a durable wall, a hook is not required.)
4. The diameter of bars used for the ends and corners of walls must be 12 mm.
5. Where a connection is needed, it must be done by welding.
6. (Attach to the frame and foundation.)
7. Long, rectangular pedestal (a solid reinforced concrete structure).

(page 63)

Table and Figure 42
 Fences of Reinforced Concrete-Block Structure
 (Ordinance, Article 62-8)

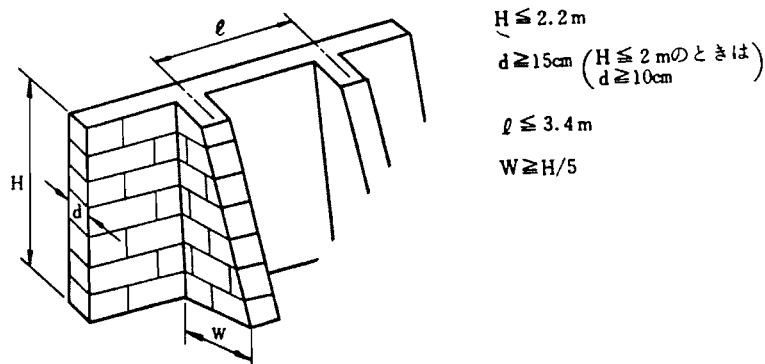

Keys

1. (When H is less than or equal to 2 meters, d is greater than or equal to 10 cm.)
2. The height of a foundation is greater than or equal to 35 cm.
3. The depth of the legs of an underground foundation is greater than or equal to 30 cm.
4. Horizontal bars in the wall top and foundation must be greater than or equal to 9 mm in diameter.
5. The size of reinforcing bars for a wall must be greater than or equal to 9 mm in diameter.
6. An interval between reinforcing bars (both horizontal and vertical) must be less than or equal to 80 cm.
7. Attachment of (A) horizontal bars of a wall top and foundation and (B) vertical and horizontal bars of a wall are as follows.

Vertical bars are hooked to horizontal bars of (A), (except when a bar is fixed in the foundation to a depth of 40 times or more of the diameter of the bar). To these vertical bars, the horizontal bars of a wall are hooked.

4
(4) Steel frame structure

Steel, cement, and glass are important materials that have brought a new dawn to modern buildings. With the recent trend toward highrise, earthquake-resistant (addition of tenacity), light-weight buildings, their importance has been increasing.

In steel frame structures, utilization of cross sectional area is great and any construction method can be used relatively freely. However, it is highly susceptible to the influence of localized stress and lacks durability and fire preventability. Therefore, provisions are provided concerning these areas (Ordinance, Articles 63 through 70).

(a) Since cast iron has the demerit of being frail, it cannot be used where stresses other than compressive and contact stresses exist. In other words, it cannot be used where bending stress, shearing stress, and pulling stress exist (Ordinance, Article 64).

(b) In order to prevent destruction due to buckling, the effective length-width ratio of compressive materials must be under 200 in the case of pillars and 250 in the case of other parts (Ordinance, Article 65).





(page 64)

Table and Figure 43
Effective Length-and-Width Ratio

有効細長比 $\lambda = \frac{\text{座屈長さ } l_k}{\text{断面の最小2次半径 } i}$

ここで、
 $i_x (\text{x軸方向の } i) (\text{cm}) = \sqrt{\frac{\text{断面2次モーメント (x軸)} I_x (\text{cm}^4)}{\text{部材断面積 } A (\text{cm}^2)}}$

l_k は、部材端部の支持状態に応じて定めるが、一般に下表の数値を標準とする。

l_k の値	l	$0.5l$	$0.7l$	$2l$
	両端ピン	両端固定	1端ピン 1端固定	1端自由 1端固定
部材端部の支持状態				

Keys

1. Effective length-and-width ratios

$$= \frac{\text{length of buckling -- } l_k}{\text{smallest second degree constant radius of cross section}}$$

Note that;

$$i_x (\text{"i" in the direction of x axis})(\text{cm}) = \sqrt{\frac{\text{cross-sectional second degree moment (x axis) } I_x (\text{cm}^4)}{\text{cross-sectional area of the material for a part--} A (\text{cm}^2)}}$$

2. Although the value for l_k is determined by the supporting conditions of the end of a part, generally the values in the table below are used as a standard.

3. Value of l_k

4. Supporting conditions of the end of a part

5. Fastened both ends with pins.

6. Fixed both ends.

7. Fastened one end with a pin and fixed another.

8. One end remains free and another end is fixed.

- (c) Legs of a pillar as a rule must be tightly connected to a foundation with anchor bolts (Ordinance, Article 66).
- (d) As a rule the methods of connection are limited to connection with high-strength bolts, welding, and rivets. However, in the case of small-scale buildings and when measures are taken to prevent bolts from becoming loose, ordinary bolts can be used (Ordinance, Article 67). (Refer to Table and Figure 44.)

Table and Figure 44
 Size of Buildings in which Ordinary Bolts Can Be Used
 for Connections
 (Ordinance, Article 67)

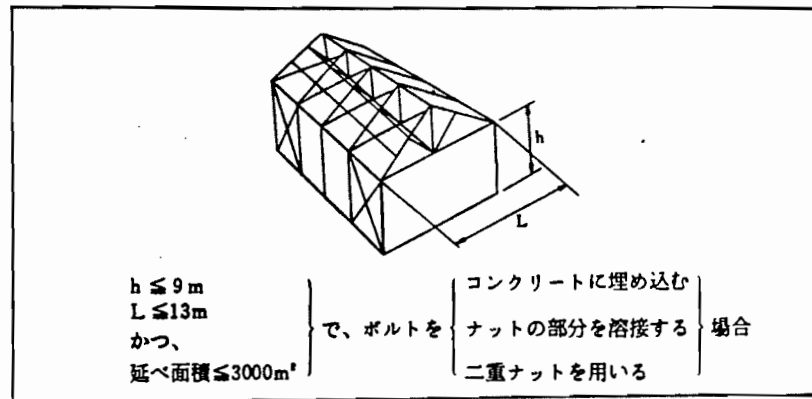

Keys

- In the case of buildings whose height is less than or equal to 9 meters, length is less than or equal to 13 meters, and gross floor area is less than or equal to 3,000 square meters; and when either a bolt is buried in concrete, a bolt and nut are welded, or double nuts are used.

(page 65)

- (e) The intervals between high-strength bolts, bolts, or rivets are regulated as well as the size of holes for a

bolt or high-strength bolt (Ordinance, Article 68).

Table and Figure 45
Connections Made with High-Strength Bolts, Bolts, or Rivets
(Ordinance, Article 68)

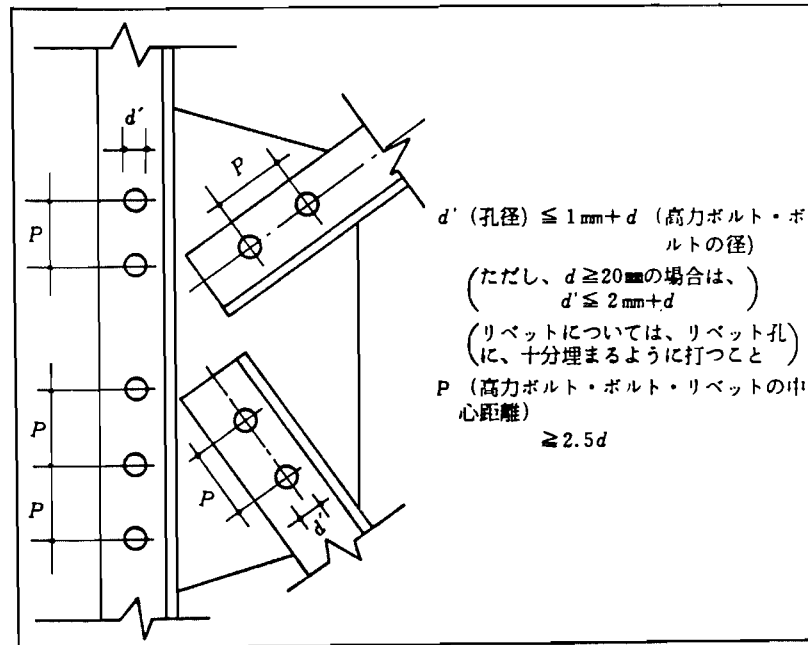

Keys

1. (Diameter of a hole)
2. (Diameter of a bolt or high-strength bolt)
3. Note that when "d" is greater than or equal to 20 mm, "d'" is less than or equal to (2 mm + d).
4. (A rivet must be driven down sufficiently to fill in the rivet hole.)
5. The distance between two center points of bolts, high-strength bolts, or rivets is greater than or equal to 2.5d.

(f) Except when safety in terms of structural durability is verified by structural calculations, steel frames, steel

rod reinforced diagonal beams, walls, roof plates, and floor plates must be arranged in a well-balanced manner (Ordinance, Article 69).

(g) Pillars for the steel frame structure of buildings of 3 stories or more must be covered with some sort of fire-proof materials (Ordinance, Article 70).

(5) Reinforced concrete structure

Reinforced concrete structures have become widespread in our country and are used for a wide range of buildings from apartments to large-scale office buildings.

Reinforced concrete structures were formerly made by assembling steel rods and pouring wet concrete into molding boxes at the construction site. Recently, however, with the development of prefabricated buildings, precast concrete structures has been increasingly used (Ordinance, Articles 71 through 79). Only Articles 72, 75, and 79 of the Ordinance apply to the small-scale buildings (whose heights are less than or equal to 4 meters and gross floor areas are less than or equal to 30 square meters) and fences (whose heights are less than or equal to 3 meters).

(a) Materials for concrete (aggregate, water, mixing materials) should not include anything that causes the rusting of steel rods or prevents concrete from setting and hardening. Aggregate should be of an appropriate size to be poured in between steel rods or a steel rod and molding box, and even-size and good shape. It also should not obstruct the strength, durability, or fire preventability

of concrete (Ordinance, Article 72).

(b) The end of a steel rod must be in the shape of hook and anchored. (Deformed steel rods are not required to have a hook at the end except when used for external corners of pillars and beams or smokestacks. Joints of primary rods must be made at a place where pulling stress is minimal and for a certain length each rods must be laid side-by-side (Ordinance, Article 73).

Table and Figure 46
 Joints of Steel Rods
 (Ordinance, Article 73 and Reference Items)

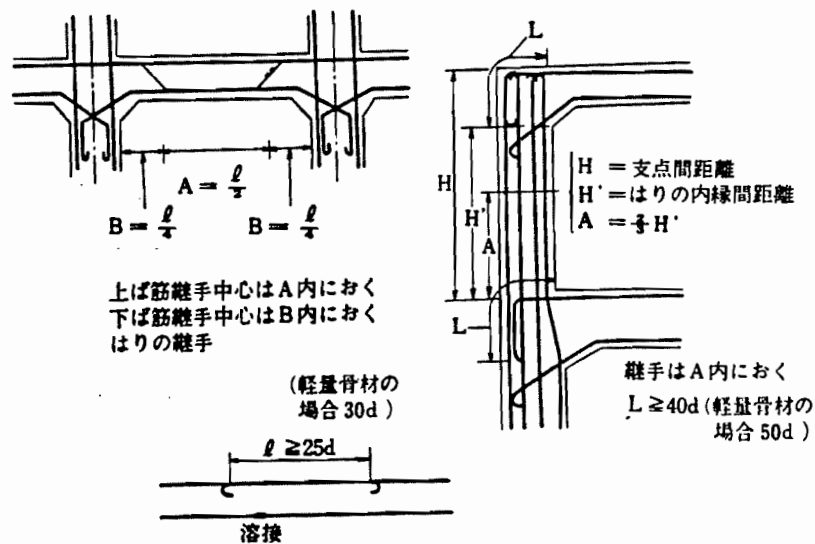

Keys

1. The center of a joint of upper end rods must be placed within A.
2. The center of a joint of under end rods must be placed within B.
3. Joints of steel rods in beams
4. Distance between fulcrums
5. Distance between the inside surfaces of beams

6. (In the case of light-weight aggregate, "l" is greater than or equal to 30d.)
7. Welding
8. A joint must be placed within A.
9. (In the case of light-weight aggregate, "L" is greater than or equal to 50d.)

(page 67)

(c) Strength of concrete must be over 120 kg/cm² in four-week-duration compressive strength in the case of ordinary concrete and over 90 kg/cm² in four-week-duration compressive strength in the case of concrete with light-weight aggregate. In addition, concrete must meet the standards for strength of concrete determined by the Minister of Construction (Construction Ministerial Notification. These are the standards required for safety in relation to the standard strength in design.) The mixture should be such that the finish will be uniform in quality (Ordinance, Article 74). (Reference: Testing methods for strength designated by the Minister of Construction require compliance with Japan Industrial Standards (JIS A 1108 or JIS A 1107). (1970 Construction Ministerial Notification No. 1834)

(d) Except when measures are taken to promote setting and hardening of concrete, during curing (during the period concrete is filled and the subsequent 5 days) filled concrete must be protected from cold temperatures (the temperature of concrete must be less than [sic] or equal to 5 degrees C.), vibration, or dryness so that the setting and hardening of concrete is not disturbed (Ordinance, Article 76).

(e) The slats of molding boxes should not be removed for the period indicated in (B) of Table and Figure 47. As a rule, the props of molding boxes should not be removed for the period indicated in (B). However, when it is verified that concrete has acquired the strength shown in (C), the props of a molding box can be removed before the passing of the indicated period (Ordinance, Article 76).

Table and Figure 47
 The Period for the Retention of Molding Boxes
 (1971 Construction Ministerial Notification No. 110)

(イ)		(ロ)			は	
せき板 又は支 柱の区 分	建築物 の部分	セメントの種類	存 置 日 数			
			存置期間中の平均気温			
			摂氏15度 以上	摂氏15度 未満摂氏 5度以上	摂氏5度 未満	コンクリートの圧縮 強度
せき板	基礎、 はり 側、柱 及び壁	早強ポルトランドセメント	2	3	5	
		普通ポルトランドセメント、高炉セメントA種、フライアッシュセメントA種及びシリカセメントA種	3	5	8	
		高炉セメントB種、フライアッシュセメントB種及びシリカセメントB種	5	7	10	
	早強ポルトランドセメント	4	6	10		

支 柱	版下及 びはり 下	普通ポルトランドセメント、高炉セメントA種、フライアッシュセメントA種及びシリカセメントA種	6	10	16	コンクリートの4週 圧縮強度の50パーセント	
		高炉セメントB種、フライアッシュセメントB種及びシリカセメントB種	8	12	18		
	版 下	早強ポルトランドセメント	8	12	15	コンクリートの4週 圧縮強度の85パーセント	
		普通ポルトランドセメント、高炉セメントA種、フライアッシュセメントA種及びシリカセメントA種	17	25	28		
		高炉セメントB種、フライアッシュセメントB種及びシリカセメントB種	28	28	28		
	はり下	早強ポルトランドセメント				28	コンクリートの4週 圧縮強度の100パーセント
		普通ポルトランドセメント、高炉セメントA種、フライアッシュセメントA種及びシリカセメントA種					
		高炉セメントB種、フライアッシュセメントB種及びシリカセメントB種					

Keys

1. Section of slat or prop
 2. Part of building
 3. Kind of cement
 4. Days of retention
 5. Average temperature during the period of retention
 6. 15 degrees C. or higher
 7. 5 degrees C. or higher, but lower than 15 degrees C.
 8. Lower than 5 degrees C.
 9. Compressive strength of concrete
 10. Slat
 11. Foundations, sides of beam, pillars, and walls
 12. Quick-setting portland cement
 13. Ordinary portland cement, blast furnace cement type A, fly ash cement type A, and silica cement type A
 14. Blast furnace cement type B, fly ash cement type B, and silica cement type B
 15. 50 kg per 1 cm²
- (page 68)
16. Under plates and under beams
 17. 50 percent of four-week-duration compressive strength of concrete
 18. Prop
 19. Under plates
 20. 85 percent of four-week-duration compressive strength of concrete
 21. Under beams
 22. 100 percent of four-week-duration compressive strength of concrete

(f) In regard to pillars made of reinforced concrete, the number of primary rods, the space between belt rods, belt rod ratios, minimum dimensions, and the cross-sectional area of primary rods are regulated (Ordinance, Article 77). (Refer to Table and Figure 48.) The calculation method for the belt rod ratio should be based on the standard determined by the Minister of Construction (Construction Ministerial Notification). However, it is necessary to keep the ratio of the cross-sectional area of a belt rod to the cross-sectional area of concrete of the direction of the main axis of the pillar between two belt rods to at least 0.2 percent or more. (Concerning the standards for belt rods, refer to 1971 Construction Ministerial Notification No. 2056.)

(g) As for floor plates made of reinforced concrete, thickness must be greater than or equal to 8 cm and also greater than or equal to $1/40$ of the effective length of the span in the direction of the shorter dimensions. The space between pulling steel rods in the place where a floor receives the maximum bending moment should be less than or equal to 30 cm in the direction of the longer dimensions. In addition, the space must be less than or equal to three times the thickness of the floor plate. Concerning the joints of precast reinforced concrete floor plates, regulations on transfer of existing stress and others are provided (Ordinance, Article 77-2).

(h) A beam made of reinforced concrete must have double

rods. A standard for the space between rib rods is also provided. There are some exceptional provisions concerning precast reinforced concrete beams (Ordinance, Article 78). (Refer to Table and Figure 48.)

(page 69)

Table and Figure 48
Each Part of a Reinforced Concrete Structure
(Ordinance, Articles 77 and 78)

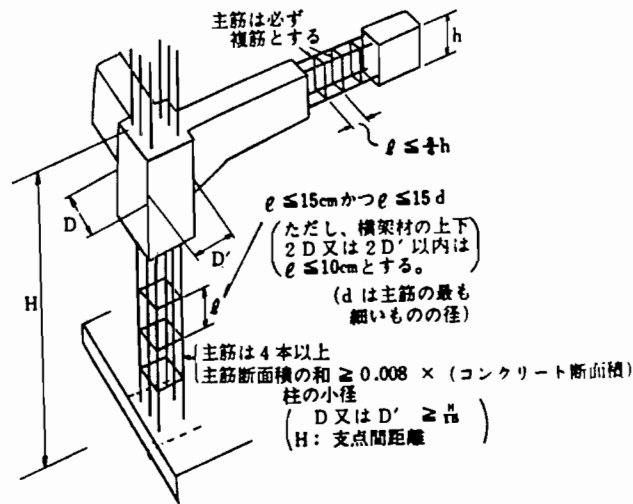

Keys

1. There must always be more than one primary rod..
2. And
3. (However, within $2D$ or $2D'$ under or above crossbeams, " l " is equal to 10 cm or less.)
4. (" d " is the diameter of the thinnest rod among the primary rods.)
5. 4 or more primary rods
6. The total of the cross-sectional areas of all primary rods must be greater than or equal to ($0.008 \times$ the cross-sectional

area of a concrete part).

7. The smaller dimension of a pillar ("D" or "D'" must be greater than or equal to $\frac{H}{15}$. "H" is for the distance between fulcrums.)

(i) Durable walls

Since durable walls are important in terms of earthquake-resistance, special standards are provided concerning thickness, reinforcement around openings, arrangement and distribution of rods, and other items (Ordinance, Article 78-2).

Table and Figure 49
Structure of Durable Walls
(Ordinance, Article 78-2)

壁の厚さ		≥12cm	
開口部周囲の補強筋		径≥12mm	
壁の配筋	縦筋及び横筋	径≥9mm	
	配筋間隔 (構造計算又は実験 による場合を除く。)	シングル配筋	≥30cm (平家建 ≥35cm)
		ダブル配筋	≥45cm (平家建 ≥50cm)

周囲の柱・はりとの接合		存在応力を伝えること
壁合式の構附加の基準	壁の長さ	≥45cm
	端部・隅角部の補強筋	縦筋、径≥12mm
	頂部・脚部の接合	壁ばり・布基礎・基礎ばり(その厚さ≥耐力壁の厚さ)に存在応力を伝えること

Keys

1. Thickness of the wall
2. Reinforcing rod around the opening

3. Arrangement of rods in the wall
4. Vertical rods and horizontal rods
5. Spacing of rods (except when decided by structural calculation or experiment)
6. Single arrangement of rods
7. Double arrangement of rods
8. Diameter
9. One-story house
(page 70)
10. Connection to nearby pillars and beams
11. Connect so that existing stress is transferred.
12. Additional standards for the case of bearing wall structures
13. Length of wall
14. Reinforcement of end and corner parts
15. Connection of top and leg parts
16. Vertical rods with a diameter greater than or equal to 12 mm.
17. Connect so that existing stress is transferred to wall beams, long rectangular pedestals, and foundation beams (their thicknesses must be thicker than the thickness of the durable wall).

(j) In order to assure durability of steel rods (mainly in terms of rustproofing) and increase fireproofness of steel rods, it is important to maintain a cover of concrete of a certain thickness over steel rods. Depending on the position of parts, the covering thickness is provided as shown in Table and Figure 50.

As for prestressed concrete structures, a kind of reinforced concrete structure, provisions concerning reinforced concrete structure generally apply, except that the

structural calculation methods are different.

Table and Figure 50
Minimum Thickness of Concrete Covering Steel Rods
(Ordinance, Article 79)

建築物の部分		かぶり厚さ	
壁	耐以外 力の 壁壁	一般	2 cm
		土に接する 部分	4 cm
	耐 力 壁	一般	3 cm
		土に接する 部分	4 cm
床	一般	2 cm	
	土に接する部分	4 cm	
柱・はり	一般	3 cm	
	土に接する部分	4 cm	
基礎	布基礎の立上り部分	4 cm	
	その他	6 cm (捨コンクリートの部分を除く。)	

Keys

1. Part of building
2. Thickness of cover
3. Wall
4. Walls other than durable walls
5. Durable walls
6. General
7. Portion in contact with soil
8. Floor
9. Pillars and beams
10. Pedestals
11. Standing portion of long rectangular pedestals
12. Others

13. Except for the portion of waste concrete

(page 71)

(6) Steel frame and reinforced concrete structure

The thickness of concrete covering steel frames should be 5 cm or more. In addition, related provisions concerning previously-mentioned steel frame structures and reinforced concrete structures apply with necessary modifications (Ordinance, Articles 79-2 through 79-4).

(7) Simple concrete structure

Although the simple concrete structure belongs in the category of monolithic construction, its structural characteristics are similar to those of masonry. Therefore, as for provisions on structural design, such as the thickness and length of walls, the provisions concerning masonry structure apply, and as for provisions on actual construction procedures, the provisions concerning reinforced concrete structures apply in order to ensure safety (Ordinance, Article 80).

(8) Supplementary regulations concerning structural methods

There may be some structural methods based on the development of new technology that fall under a category of structure previously mentioned in (1) through (7) but do not fit each specific standard. Or there may be some cases based on the development of new technologies that are totally different from structures described in (1) through (7). Article 80-2 of the Ordinance provides that the Minister of Construction can set up new technical standards (supplementary provisions) for newly developed structural methods. A supplementary

provision is intended to provide technical standards for a new method along the same lines as those for which provisions described in ① through ③ are given. In regard to a revolutionarily new technology that belongs to an entirely different technical system from the ones mentioned in ① through ③, it is appropriate to entrust to the Minister of Construction the decision as to whether or not a technical standard based on Article 38 of the Building Standards Law should be provided.

One example of supplementary provisions is "Technical Standards Concerning the Structural Method of Buildings and Their Structural Parts in Prestressed Concrete Structures" (an example of "Structures Different from Those Described in (1) through (7)"). (1973 Construction Ministerial Notification No. 949)

(page 72)

(4) Structural Calculation

As mentioned in the beginning of this section (Table and Figure 5), the provision requires verification of safety in terms of structural durability of a building of a certain size or larger by structural calculations (Ordinance, Article 20).

Structural calculations for buildings with a height of 60 meters or less should comply with the provisions of Section 8 of the Building Standards Law Enforcement Ordinance. In the case of portions above the second story that are connected with a structural method that does not transfer stress to each other, such as expansion joints, each story is considered as a separate building and structural calculations must be done on that basis (Ordinance, Article 81).

Structural calculations for a building whose height exceeds 60 meters must be done by the structural calculation methods approved as safe in terms of structural durability by the Minister of Construction (Ordinance, Article 81-2). (In practice, such structural calculations are first evaluated by the Japan Building Center and then submitted for the approval of the Minister of Construction.)

For buildings that require structural calculations, needless to say, previously-mentioned standards of ① Principles of Structural Design, ② Structural Parts and Materials, and ③ General Structural Standards, apply.

(1) Principles of structural calculations

The new structural calculation method, revised in 1980 and effective on 1 June 1981, is said to be epoch-making, since it has determined a design method by examination and calculation of ultimate strength, including plasticity area as well as the usual design method based on permissible stress, that applies to the elasticity area. Another new feature is that, in order to obtain a well-balanced structural plan, shear modulus and eccentricity must be examined.

In this new method of structural calculation, specific methods vary depending on the kind of structure, height, and other elements. Specific techniques including the calculation for the previously-mentioned buildings whose height exceeds 60 meters are shown in Tables and Figures 51 and 52 (Ordinance, Articles 81 through 82-4).

(page 73)

Table and Figure 51
Structural Calculation Methods for Buildings
by Structure and Height
(Ordinance, Articles 81 through 82-4)

構造種別・高さ等		①木造建築物等 〔昭55建告 第1790号〕	② 高さ $\leq 31\text{m}$ (①を 除く)	③ 31m < 高さ ≤ 60 m	④ 60m < 高さ
必要な 構造計算	一次設計	許容応力度計算〔令82条〕 $\left(\begin{array}{l} \text{荷重・外力による建築物} \\ \text{各部の応力度} \end{array} \right) \leq \left(\begin{array}{l} \text{各部の材料の許容} \\ \text{応力度} \end{array} \right)$ 〔令82条、令83条-88条〕 〔令89条-94条〕			建設大臣の認める構造計算方法。 (こととなる。手続等は、別途省令で定められる。 従って、確認申請前に建設大臣に認定を申請する)
	二次設計	(二次設計不要)	層間変形角計算〔令82-2条〕 $\left(\begin{array}{l} \text{地震力による} \\ \text{層間変形角} \end{array} \right) \leq 1/200$ 〔令82-2条、(又は1/120) 令88条〕	剛性率・偏心率計算〔令82-3条1号・2号〕 (各階) 剛性率 $\geq 6/10$ 、 (各階) 偏心率 $\leq 15/100$	
構造計算の区分			その他の計算 〔令82-3条3号、昭55建告第1791号〕		
注：②の建築物について、水平耐力計算を行った場合は、剛性率・偏心率等の計算の必要はない。すなわち、②の建築物については、層間変形角計算の次に、二通りの構造計算がある。					

Keys

1. Wooden Buildings Et Cetera (1980 Construction Ministerial Notification No. 1790)
2. Height less than or equal to 31 meters (except for 1).
3. Height greater than or equal to 31 meters but less than or equal to 60 meters.
4. Height greater than 60 meters.
5. Kind of structure and height
6. Required structural calculation
7. Kind of structural calculation
8. First stage design
9. Second stage design
10. Permissible stress calculation (Ordinance, Article 82)

{Degree of stress on each part of a building caused by load and external forces (Ordinance, Articles 82 and 83 through 88) } is less than or equal to { permissible stress of the material of each part (Ordinance, Articles 89 through 94) }.
11. Second stage design is not required.
12. Calculation for variable angle between stories (Ordinance, Article 82-2)

{Deformed angle between stories due to earthquake forces (Ordinance, Articles 82-2 and 88) } is less than or equal to 1/200 (or 1/120).
13. Shear modulus and eccentricity calculations (Ordinance, Article 82-3, 1 and 2)

Shear modulus of each story is greater than or equal to 6/10.
Eccentricity of each story is less than or equal to 15/100.

- 14. Other calculations (Ordinance, Article 82-3, 3; 1980 Construction Ministerial Notification No. 1791)
- 15. Horizontal durability calculation (Ordinance, Article 82-4)
 - { The horizontal durability that each story retains } is greater than or equal to { the horizontal durability that each story is required to retain } .
- 16. Structural calculation methods approved by the Minister of Construction. (The structural calculation method must be approved by the Construction Minister before applying for building certification. The application procedures are described in a separate Construction Ministerial Ordinance.)
- 17. Note: Concerning buildings belonging to category 2, when the horizontal durability calculation is made, shear modulus and eccentricity calculations are not required. In other words, for buildings in 2, there are two methods of structural calculation after the calculation for variable angle between stories.

(page 74)

Table and Figure 52
Flow Chart of Structural Calculations
(Outline)

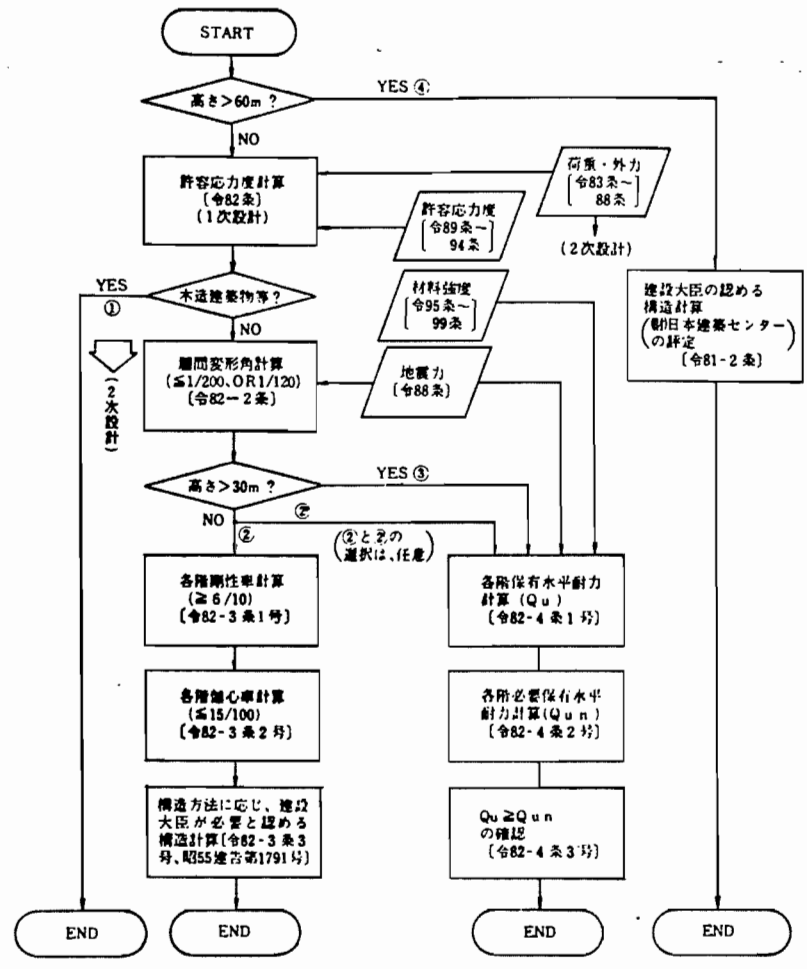

Keys

1. Is height more than 60 meters?
2. Calculation for permissible stress (Ordinance, Article 82)
(First stage design)
3. Is this a wooden building et cetera?
4. (Second stage design)
5. Calculation for the variable angle between stories (less than or equal to 1/200, or 1/120) (Ordinance, Article 82-2)
6. Is height more than 30 meters?
7. Shear modulus calculation for each story (greater than or equal to 6/10) (Ordinance, Article 82-3,1)
8. Eccentricity calculation for each story (less than or equal to 15/100) (Ordinance, Article 82-3, 2)
9. Structural calculations acknowledged as necessary by the Minister of Construction depending on the type of structural method. (Ordinance, Article 82-3, 3; 1980 Construction Ministerial Notification No. 1791)
10. Load and external forces (Ordinance, Articles 83 through 88)
11. Permissible stress (Ordinance, Articles 89 through 94)
12. Strength of materials (Ordinance, Articles 95 through 99)
13. Earthquake force (Ordinance, Article 88)
14. Choice between ② and ②' is optional.
15. Calculation of the horizontal durability retained by each story (Qu) (Ordinance, Article 82-4, 1)
16. Calculation of the horizontal durability each story is required to retain (Qun) (Ordinance, Article 82-4,2)
17. Confirm that (Qu) is greater than or equal to (Qun). (Ordinance,

Article 82-4, 3)

18. Structural calculations approved by the Minister of Construction (Evaluation by the Japan Building Center) (Ordinance, Article 81-2)
19. Remarks:
 - (1) As for the computation method to obtain D_s and F_{es} in the calculation of the horizontal durability each story is required to retain, refer to 1980 Construction Ministerial Notification No. 1792.
 - (2) Concerning earthquake force, as for the computation methods to obtain Z , R_t , and A , as well as soft ground areas, refer to 1980 Construction Ministerial Notification No. 1793.
 - (3) As for permissible stress and strength of various kinds of materials, refer to 1980 Construction Ministerial Notification Numbers 1794, 1795, and 1799.

145

(page 75)

Table and Figure 53
 The Limits of Wooden Buildings Et Cetera
 (Ordinance, Article 82-2; 1980 Construction Ministerial
 Notification No. 1790)

構造種別	規模等の要件	その他の要件
木造	なし	なし
組積造・補強コンクリートブロック造	地上階数 ≤ 3	なし
鉄骨造	地上階数 ≤ 3 、高さ $\leq 13\text{m}$ (軒高 $\leq 9\text{m}$)、柱間隔 $\leq 6\text{m}$ 、延べ面積 $\leq 500\text{m}^2$	[標準せん断係数 ≥ 0.3]で、許容応力度計算に適合すること。水平力負担筋かいの軸部の降伏以前に、その端部・接合部が破断しないこと。
鉄筋コンクリート造・鉄骨鉄筋コンクリート造・これらの併用構造	高さ $\leq 20\text{m}$	地上部分各階の耐力壁・柱・耐力壁以外の壁(上下、躯体に繋結したもの)等の水平断面積が、下式に適合すること。(SRC造の場合、7→10)。 $\sum 25A_w + \sum 7A_c \geq ZW A_i$ <p>[A_w: 計算方向の耐力壁の水平断面積 (cm²) A_c: 柱・計算方向の壁(耐力壁を除く)の水平断面積 (cm²) Z: 地震力地域係数 [令88条1項] W: その階が支える部分(上階)の固定荷重と積載荷重の和(多層地域では、更に積上荷重を加える)(kg) A_i: 地震例せん断力係数の分布係数 [令88条1項]</p>
木造・組積造・補強コンクリート造の併用構造、これらと鉄筋コンクリート造・鉄骨鉄筋コンクリート造の併用構造	地上階数 ≤ 3 、高さ $\leq 13\text{m}$ (軒高 $\leq 9\text{m}$)、柱間隔 $\leq 6\text{m}$ 、延べ面積 $\leq 500\text{m}^2$	鉄骨造・RC造・SRC造の有る階は、それぞれ上欄「その他の要件」に適合すること。
建設大臣が性能認定した工業化住宅 [昭和48年建設省告示第2031号]	なし	なし
その他、建設大臣が同等以上の地震に対する安全性を認めたもの	——	——

146

Keys

1. Kind of structure
2. Conditions concerning size
3. Other conditions
4. Wooden structure
5. None
6. Masonry structure, reinforced concrete-block structure
7. The number of stories above ground is 3 or less.
8. Steel frame structure
9. The number of stories above ground is less than or equal to 3. The height is less than or equal to 13 meters. (The height to the eaves is less than or equal to 9 meters.) The space between pillars is less than or equal to 6 meters. The gross floor area is less than or equal to 500 square meters.
10. With the standard shear coefficient (greater than or equal to 0.3), it must fit the permissible stress calculation. Before the axial part of a diagonal beam that bears horizontal forces gives way, the ends and joints parts of the diagonal beam should not be broken apart.
11. Reinforced concrete structure, steel frame and reinforced concrete structure, and combined structure of the two
12. Height less than or equal to 20 meters.
13. Horizontal cross-sectional areas of durable walls, pillars, and walls other than durable walls (those firmly fixed at both the upper and lower edges to the main body) of each story above ground must fit the following equation. (In the case of steel frame reinforced concrete structures, use 10

instead of 7.)

$$(\sum 25A_w + \sum 7A_c) \geq ZW A_i$$

A_w : Horizontal cross-sectional area of the durable wall in the direction of calculation (cm²)

A_c : Horizontal cross-sectional areas of pillars and walls other than durable walls in the direction of calculation (cm²)

Z : Regional coefficient of earthquake force (Ordinance, Article 88, Item 1)

W : The total of fixed load and full cargo load of the portion (upper stories) the story bears (within areas of heavy snow fall, add the load of fallen snow). (kg)

A_i : Distribution coefficient of earthquake layer shear force coefficient (Ordinance, Article 88, Item 1)

14. Combinations of wooden, masonry, and reinforced concrete-block structures; combined structure of one of the three with either reinforced concrete or steel frame and reinforced concrete structures.
15. In case a story (or a portion of it) is made of a steel frame structure, reinforced concrete structure, and/or steel frame and reinforced concrete structure, each portion must meet the corresponding required conditions described above.
16. Prefabricated houses whose performance has been certified by the Minister of Construction (1973 Construction Ministerial Notification No. 2031).
17. Other structures which have been acknowledged by the Minister of Construction to be equally safe or safer than those listed

above.

(page 76)

(a) Permissible stress calculations

Regardless of type of structure or height, permissible stress calculations are required for all buildings that require structural calculations under Article 20 of the Building Standards Law (Ordinance, Article 82).

- a) It is necessary to calculate the stress occurring in primary parts of a building due to load and external forces. Calculation methods are not specified but are expected to be appropriate to the structural type.
- b) After calculating stress values, obtain the total stress in accordance with the combinations indicated in Table and Figure 54 below. Then, based on the total stress calculate the short-term and long-term stresses for primary parts.
- c) Check to see that stress of a cross section of a material does not exceed the stress of the material itself.
- d) As for (a) through (c), calculation methods for strength are provided. However, whenever necessary, check the materials for each part of structure for the degree of deformation and post-shock conditions in order to make sure that there is no impediment to use of the given calculation methods.

Table and Figure 54
 Combination of Stresses
 (Ordinance, Article 82)

	状 態	応 力 の 組 合 せ		備 考
		一般の場合	多雪地域内の場合	
長期の応力	常 時	G + P	G+P+S	
短期の応力	積雪時	G+P+S	G+P+S	
	暴風時	G+P+W	G+P+W	建築物の転倒、柱の引抜き等を検討する場合は、Pは実況に応じて減らすことができる
			G+P+W+S	
地震時	G+P+K	G+P+K+S		
G; 固定荷重による応力 P; 積載荷重による応力 S; 積雪荷重による応力 W; 風圧力による応力 K; 地震力による応力				

Keys

1. Long-term stress
2. Short-term stress
3. Condition
4. Combination of stresses
5. Case of general areas
6. Case of areas with heavy snow fall
7. Remarks
8. Normal times
9. Times of heavy snow fall
10. Times of strong winds
11. Times of earthquake
12. When examining collapse of a building or uprooting of a pillar, the value of P can be reduced depending on the actual

situation.

- 13. G: Stress due to fixed load
- 14. P: Stress due to weight of loaded cargo
- 15. S: Stress due to fallen snow
- 16. W: Stress due to wind pressure force
- 17. K: Stress due to earthquake force

(page 77)

(b) Calculation for the variable angle between stories

This is the first step of the so-called second stage design in order to ensure safety against earthquakes. This calculation is required for aboveground portions of all buildings except "wooden buildings et cetera" and "buildings whose height exceeds 60 meters" (Ordinance, Article 82-2).

Table and Figure 55
 Calculation of the Variable Angle between Stories

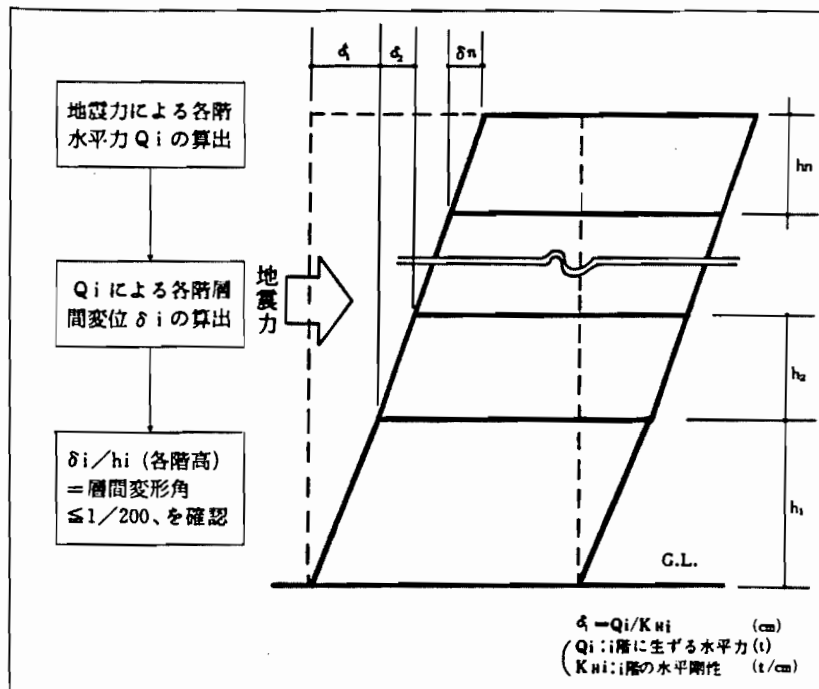

Keys

1. Computation of horizontal force (Q_i) on each story due to earthquake force
2. Computation of displacement (δ_i) between each story by Q_i .
3. δ_i/h_i (height of each story) is the variable angle between stories. Confirm that δ_i/h_i is less than or equal to $1/200$.
4. Q_i : Horizontal force occurred in story "i" -- (t)
5. KH_i : Horizontal rigidity of story "i" -- (t/cm)
6. Earthquake force

The intention of the regulation concerning the variable angle between stories is this: when the variable angle is great (in other words, when a building is too flexible), it not only damages and disintegrates secondary parts and materials such as finish materials and plumbing facilities, but also has harmful effects such as transmitting vertical vibration to the main body. When measures are taken to cope with deformation, the value of $1/200$ can be eased to $1/120$.

(c) Calculation for shear modulus

This is the second step in the second stage design of a building whose height is less than or equal to 31 meters (except for "wooden buildings et cetera"). It is intended to ensure balance of rigidity in the whole building (or each story). As mentioned previously, when the horizontal durability retained by each story is checked, it is not necessary to check the shear modulus of each story.

(page 78)

If there is a great difference in rigidity between each story, it is possible that a story with little rigidity will first give way to a condition of plasticity when subject to large horizontal forces (earthquakes). Then, more and more stress will be concentrated on that story, and as a result deformation of the story will be greater.

Therefore, it is desirable that the horizontal rigidities opposed to the horizontal forces each story must bear should be almost equal. (It is desirable that shear modulus is close to 1.0 for every story. But, judging from the past experiences with earthquakes, the permissible value has been set at 0.6.) (Ordinance, Article 82-3,1)

Table and Figure 56
Calculation of Shear Modulus

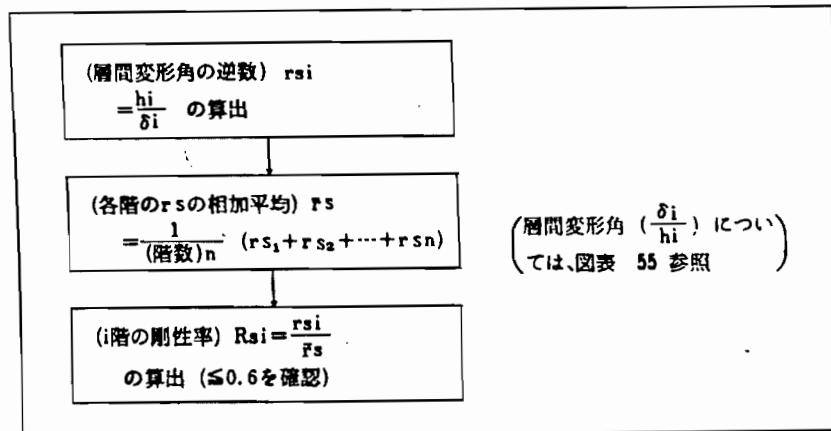

Keys

1. Computation of $rs_i = \frac{h_i}{\delta_i}$
(rs_i is the inverse of the variable angle between stories.)
2. $\bar{rs} = \frac{1}{(\text{number of stories})n} (rs_1 + rs_2 + \dots + rs_n)$
(\bar{rs} is the arithmetic mean of the rs of each story.)

3. Computation of $R_{si} = \frac{r_{si}}{r_i}$

(shear modulus of story "i")

(Confirm that R_{si} is greater than or equal to 0.6.)

4. (As for the variable angle between stories $\left[\frac{\delta_i}{h_i} \right]$, refer to Table and Figure 55.)

(d) Calculation of eccentricity

The elements of pillars and walls that resist horizontal forces on one floor of a building are varied. In the case of earthquake forces, it is possible that torsional forces will work to create torsional vibration. As a result, in earthquakes, pillars in areas where there are not many durable elements tend to collapse.

The checking of eccentricity is intended to regulate variations in durable elements against horizontal forces. As same as the previous section (c), when the horizontal durability retained by each story is checked, the eccentricity calculation is not required (Ordinance, Article 82-3, 2).

(page 79)

Table and Figure 57
Calculation of Eccentricity

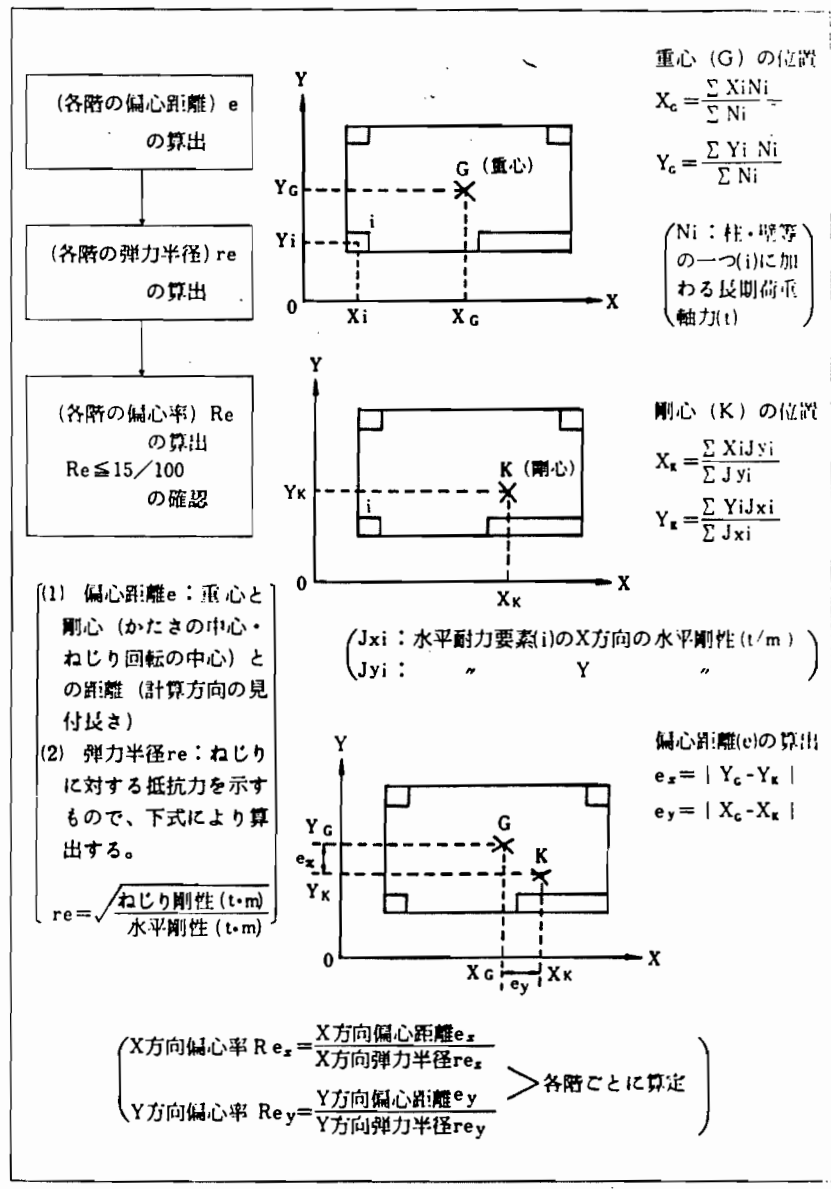

155

Keys

1. Computation of e ("e" is the eccentric distance of each story.)
2. Computation of re ("re" is the elastic radius of each story.)
3. Computation of Re ("Re" is the eccentricity of each story.)

Confirm that "Re" is less than or equal to 15/100.

- 4-1. e (eccentric distance): the distance between the center of gravity and the center of rigidity (the center of hardness and the center of torsional revolution) (surface distance in the direction of calculation)
- 4-2. re (elastic radius): it indicates the resistance power against torsion, and is obtained by computing the following equation.

$$re = \sqrt{\frac{\text{torsional rigidity (t.m)}}{\text{horizontal rigidity (t.m)}}}$$

5. Center of gravity
6. Center of rigidity
7. Position of the center of gravity (G)
8. (Ni: long-term load imposed on one (i) of pillars or walls; axis force (t))
9. Position of the center of rigidity (K)
10. Jxi: horizontal rigidity of the horizontal durable element (i) in the direction of X (t/m).
Jyi: horizontal rigidity of the horizontal durable element (i) in the direction of Y (t/m).
11. Computation of eccentric distance (e)
12. Eccentricity (Rex) in the direction of X
= $\frac{\text{Eccentric distance in the direction of X (ex)}}{\text{Elastic radius in the direction of X (rex)}}$
Eccentricity in the direction of Y (Rey)

156

$$= \frac{\text{Eccentric distance in the direction of Y (ey)}}{\text{Elastic radius in the direction of Y (rey)}}$$

Compute "Rex" and "Rey" for each story.

(page 80)

(e) Other calculations

Other calculations are the third step in the second stage design. Just as in the previously-mentioned sections (c) and (d), when the horizontal durability retained by each story is checked, other calculations are not required.

Although specific methods of calculation are to be determined by the Minister of Construction, the following calculations are currently provided for reinforced concrete structures and steel frame and reinforced concrete structures (Ordinance, Article 82-3; 1980 Construction Ministerial Notification No. 1791).

Table and Figure 58
Structural Calculations Required for Earthquake Resistance
(1980 Construction Ministerial Notification No. 1791)

構造種別	必要な構造計算						
鉄骨造・その併用構造	<p>(1) 水平力負担筋かいを設けた地上部分各階においては、地震力による応力を割増しして、許容応力度計算(令82条2号・3号)を行う。</p> <table border="1" data-bbox="690 577 1185 787"> <tr> <td>$\frac{\text{筋かいの負担水平力}}{\text{地震力による水平力}} = \beta$</td> <td>応力の割増し率</td> </tr> <tr> <td>$\beta \leq 5/7$</td> <td>$1 + 0.7\beta$</td> </tr> <tr> <td>$\beta > 5/7$</td> <td>1.5</td> </tr> </table> <p>(2) 水平力負担筋かいの軸部の降伏以前に、その端部・接合部が破断しないことを確かめる。</p> <p>(3) 必要な場合は、柱・はり・それらの接合部の局部座屈・破断等による急激な耐力低下を生じないことを確かめる。</p>	$\frac{\text{筋かいの負担水平力}}{\text{地震力による水平力}} = \beta$	応力の割増し率	$\beta \leq 5/7$	$1 + 0.7\beta$	$\beta > 5/7$	1.5
$\frac{\text{筋かいの負担水平力}}{\text{地震力による水平力}} = \beta$	応力の割増し率						
$\beta \leq 5/7$	$1 + 0.7\beta$						
$\beta > 5/7$	1.5						
鉄筋コンクリート造・鉄骨鉄筋コンクリート造・それらとの併用構造	<p>(1)~(3)のいずれかの構造計算を行う。ただし、実験により、耐力壁・柱・はりが十分な強度・靱性をもつことが確かめられる場合を除く。</p> <p>(1) 各階の耐力壁・柱・耐力壁以外の壁(上下、躯体に緊結したもの)等の水平断面積が下式に適合することを確かめる。 (SRC造の柱については、下式中、7を10とする。)</p> $\sum 25A_w + \sum 7A_c \geq 0.75ZWA_i$ <p>Aw: 計算方向の耐力壁の水平断面積 (cm²) Ac: 柱・計算方向の壁(耐力壁を除く)の水平断面積 (cm²) Z: 地震力地域係数 [令88条1項] W: その階が支える部分(上階)の固定荷重と積載荷重の和(多雪地域では、更に積雪荷重を加える。)(kg) Ai: 地震層せん断力係数分布係数 [令88条1項]</p>						
	<p>(2) 各階の柱の水平断面積が次の式に適合することを確かめる。(SRC造の柱・これに緊結された耐力壁については、下式中、18を20とする。)</p> $\sum 18A_w + \sum 18A_c \geq ZWA_i$ <p>Aw、Z、W、Ai: 上記(1)に同じ。 Ac: 柱の水平断面積 (cm²)</p> <p>(3) 柱・はりの材端に、計算上の最大曲げモーメントが作用した場合に、その柱・はりにせん断破壊が生じないことを確かめる。</p>						

Keys

- 1. Kind of structure
- 2. Required structural calculations
- 3. Steel frame structures and their combination with other kinds of structures
- 4-1. In the case of each story above ground equipped with diagonal beams that bear horizontal forces, the premium for stress caused by earthquake forces is used in the permissible stress calculation (Ordinance, Article 82, 2 and 3).
- 5. $\frac{\text{Horizontal force borne by a diagonal beam}}{\text{Horizontal force caused by earthquake force}} = \beta$
- 6. Premium rate for stress
- 7-2. Confirm that the end parts and joint parts of the diagonal beam will not break before the axial part of the diagonal beam that bears horizontal forces gives way.
- 8-3. When necessary, confirm that localized bucklings and breaks in pillars, beams, or their joints do not cause sudden decrease in durability of structural parts.
- 9. Reinforced concrete structures, steel frame and reinforced concrete structures, combinations of one or both of these structures with other kinds of structures.
- 10. One of the structural calculations indicated in (1) through (3) (4-1, 7-2, and 8-3) are required, except when experiments verify that durable walls, pillars, and beams possess sufficient strength and tenacity.
- 11. Confirm that horizontal cross-sectional areas of durable walls, pillars, and walls other than durable walls (those firmly fixed

159

at both the upper and lower edges to the main body) in each story fit the following equation. (In the case of the steel frame and reinforced concrete structure, use 10 instead of 7 in the following equation.)

$$\sum 25A_w + \sum 7A_c \geq 0.75ZWA_i$$

A_w : Horizontal cross-sectional areas of durable walls in the direction of calculation (cm^2)

A_c : Horizontal cross-sectional areas of pillars and walls other than durable walls in the direction of calculation (cm^2)

Z : Regional coefficient of earthquake force (Ordinance, Article 88, Item 1)

W : The total of fixed load and loaded cargo weight of the portion (upper stories) that the story bears (within areas of heavy snow fall, add the load of fallen snow). (kg)

A_i : Distribution coefficient of the earthquake layer shear force coefficient (Ordinance, Article 88, Item 1).

- 12-1. Confirm that the total of horizontal cross-sectional areas of pillars in each story fits the following equation. (Concerning pillars and durable walls that are connected to the pillars of steel frame and reinforced concrete structures, use 20 instead of 18 in the following equation.)

$$\sum 18A_w + \sum 18A_c \geq ZWA_i$$

A_w , Z , W , A_i are same as those in 11-1.

A_c : Horizontal cross-sectional areas of pillars (cm^2)

- 13-3. Confirm that shear fracture does not occur in the pillar

or the beam, when the calculated maximum bending moment acts on the end parts of the material of a pillar or a beam.

(f) Calculation for the horizontal durability retained by each story

The calculation for the horizontal durability retained by each story examines the safety of a building on the basis of the theory of the so-called plastic design method. This is the second step in the second stage design for the buildings whose height exceeds 31 meters but is less than or equal to 60 meters. However, for those buildings whose height is less than or equal to 31 meters (except for "wooden buildings et cetera"), condition of the plane and other characteristics may require verification of safety by this calculation. If this calculation is done, the calculations described in section (c), (d), and (e) are unnecessary.

The horizontal durability retained by each story of a building is the total of the horizontal shearing forces of pillars, durable walls, and beams at the moment of collapse of a part or the whole of buildings due to earthquake forces.

Consequently, it is necessary to obtain the ultimate durability of each part and material (the maximum strength of materials that compose parts, that is, "strength of materials").

Specific numeric values for the strength of materials

are indicated later in section (4), but the meaning of strength of materials is the "calculated maximum stress" and "yield strength" in the case of steel materials (Ordinance, Article 82-4).

Table and Figure 59

Calculation of Retained Horizontal Durability
(Ordinance, Article 82-4; 1980 Construction Ministerial Notification No. 1792)

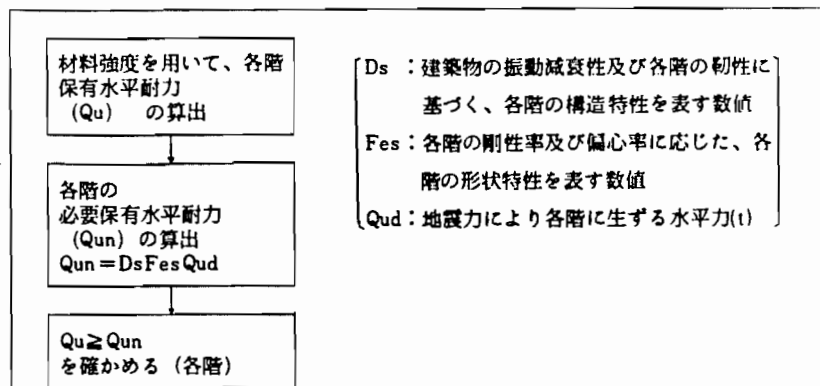

架構の形式		い	ろ	は
		剛節架構又はこれに類する形式の架構	い欄及びは欄に掲げるもの以外のもの	圧縮力を負担する筋かいによつて水平力を負担する形式の架構のうち当該筋かいの座屈による耐力の低下のおそれがあるもの又はこれに類する形式の架構
各階のD _s の算出方法（適切な他の算出方法によること）	架構の性状			
	(1) 架構を構成する部材に生ずる応力に対して局部座屈が著しく生じ難いこと等のため、塑性変形の度が特に高いもの	0.25	0.3	0.35
	(2) (1)に掲げるもの以外のもので架構を構成する部材に生ずる応力に対して局部座屈が生じ難いこと等のため、塑性変形の度が高いもの	0.3	0.35	0.4
	(3) (1)及び(2)に掲げるもの以外のもので架構を構成する部材に塑性変形を生じさせる応力に対して当該部材に局部座屈が生じないこと等のため、耐力が急激に低下しないもの	0.35	0.4	0.45
	(4) (1)から(3)までに掲げるもの以外のもの	0.4	0.45	0.5
架構の形式		い	ろ	は
		剛節架構又はこれに類する形式の架構	い欄及びは欄に掲げるもの以外のもの	各階に生ずる水平力のうち当該階の耐力壁又は筋かいによつて大部分を負担する形式の架構
各階のD _s の算出方法（適切な他の算出方法によること）	架構の性状			
	架構を構成する部材に生ずる応力に対してせん断破壊			

も可 ()	② その 他の 階	(1)	その他の耐力が急激に低下する破壊が著しく生じ難いこと等のため、塑性変形の度が特に高いもの	0.3	0.35	0.4
		(2)	(1)に掲げるもの以外のもので架構を構成する部材に生ずる応力に対してせん断破壊その他の耐力が急激に低下する破壊が生じ難いこと等のため、塑性変形の度が高いもの	0.35	0.4	0.45
		(3)	(1)及び(2)に掲げるもの以外のもので架構を構成する部材に塑性変形を生じさせる応力に対して当該部材にせん断破壊が生じないこと等のため、耐力が急激に低下しないもの	0.4	0.45	0.5
		(4)	(1)から(3)までに掲げるもの以外のもの	0.45	0.5	0.55
		柱及びはりの大部分が鉄骨鉄筋コンクリート造である階にあっては、この表の各欄に掲げる数値から0.05以内の数値を減じた数値とすることができる。				
(適切な 他の 算出 方法 による ことも 可)	F _{es} = F _s × F _e	剛 性 率		F _e の 数 値		
		(1)	0.6以上の場合	1.0		
		(2)	0.3を超え、0.6未満の場合	(1)と(3)とに掲げる数値を直線的に補間した数値		
		(3)	0.3以下の場合	1.5		
		偏 心 率		F _e の 数 値		
		(1)	0.15以下の場合	1.0		
(2)	0.15を超え、0.3未満の場合	(1)と(3)とに掲げる数値を直線的に補間した数値				
(3)	0.3以上の場合	1.5				

Keys

1. Using the strength of materials to compute the horizontal durability retained by each story (Qu).
2. Computation of the horizontal durability that each story is required to retain (Qun). $Qun = DsFesQud$
3. Confirm that (Qu) is greater than or equal to (Qun) for each story.
4. Ds: Numeric values indicating structural characteristics of each story based on the vibration damping tendency of a building and the tenacity of each story.
Fes: Numeric values indicating formal characteristics of each story according to the shear modulus and eccentricity of each story.

Qud: Horizontal force (t) that occurs in each story because of earthquake force.

(page 82)

5. A method for computing the Ds of each story (It is possible to compute this value by other appropriate methods.)
6. A story in which most pillars and beams are made of steel frame structure
7. Type of framework
8. Characteristics of framework
9. Hard joint framework or other similar types of framework
10. All types other than those listed in (A) and (C).
11. Among the types of framework in which horizontal forces are borne by the diagonal beams that bear compressive forces, those types in which exists a fear of decreased durability due to buckling of the diagonal beams bearing horizontal

forces, and similar types.

- 12-1. The type that causes an extremely high degree of plastic deformation, because localized buckling is extremely unlikely to occur because of stress created in the materials that compose the framework.
- 13-2. Other than the one listed in 12-1, the type that causes a high degree of plastic deformation, because localized buckling is unlikely to occur because of stress created in the materials that compose the framework.
- 14-3. Other than those listed in 12-1 and 13-2, the type that does not cause a sudden decrease in durability, because localized buckling does not occur in the corresponding materials because of stress that causes plastic deformation of the materials that compose the framework.
- 15-4. Other than those listed in 12-1 through 14-3.
16. Other stories
(page 83)
- 17-1. The type that causes an extremely high degree of plastic deformation, because shear fractures and other fractures that cause sudden decrease in durability are extremely unlikely to occur because of stress created in the materials that compose the framework.
- 18-2. Other than the type listed in 17-1, the type that causes a high degree of plastic deformation, because shear fractures and other fractures that cause sudden decrease in durability are unlikely to occur because of stress created in the materials that compose the framework.
- 19-3. Other than those listed in 17-1 and 18-2, the type that does

166

not cause a sudden decrease in durability, because shear fractures does not occur in the corresponding materials because of stress that causes plastic deformation to occur in the materials that compose the framework.

20. Type of framework in which most of horizontal forces occurring in each story are borne by durable walls and diagonal beams of the corresponding story.
21. In the case of stories where most of pillars and diagonal beams are made of steel frame and reinforced concrete structure, it is possible to subtract numeric values within 0.05 from the values indicated in this table and compute.
22. Computing method for the F_s of each story (It is possible to use other appropriate computing methods).
23. Shear modulus
24. Numeric value for F_s
- 25-1. Case where it is greater than or equal to 0.6.
- 26-2. Case where it is greater than 0.3 but less than 0.6
- 27-3. Case where it is less than or equal to 0.3.
28. Numeric value of an equivalent portion between the two values of 25-1 and 27-3.
29. Eccentricity
30. Numeric value for F_e
31. Case where it is less than or equal to 0.15.
32. Case where it exceeds 0.15 but is less than 0.3.
33. Case where it is greater than or equal to 0.03.

(2) Load and external forces

In structural calculations for a building, load and

external forces that affect a building can be varied according to the position and usage of the building. (page 84) However, there are five items that must always be checked (Ordinance, Article 83).

- (a) Fixed load
- (b) Full cargo load
- (c) Fallen snow load
- (d) Wind pressure force
- (e) Earthquake force

Among them, (a) through (c) affect buildings in the direction of gravity, in other words, vertically. On the other hand, (d) and (e) affect buildings in the direction perpendicular to the direction of gravity, in other words, horizontally.

In the case of outer walls of a basement -- earth pressure and water pressure, in the case of factories equipped with machinery -- vibration, in the case of floors and walls of warehouses -- impact, in the case of buildings in the water -- static water pressure, moving water pressure, and other external forces such as wave impacts, must be checked according to the actual situation.

Table and Figure 60
Load and External Forces That Affect Buildings
(Ordinance, Article 83)

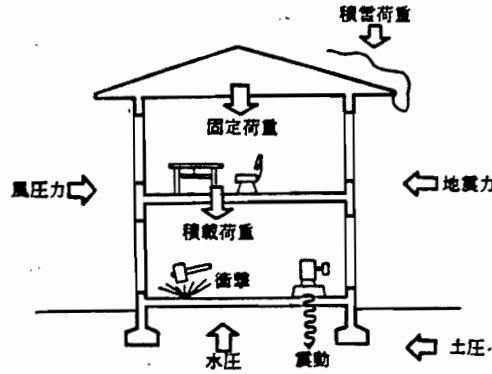

Keys

1. Wind pressure force
2. Fallen snow load
3. Fixed load
4. Full cargo load
5. Impact
6. Water pressure
7. Vibration
8. Earthquake force
9. Earth pressure

(a) Fixed load

Fixed load is the empty weight of various parts of a building. Therefore, fixed load varies depending on structure and finish materials. For general cases, fixed load of each part is based on the numeric values indicated in Table and Figure 61. For special cases, fixed load must

be calculated in accordance with the design (Ordinance, Article 84).

(page 85)

Table and Figure 61
Fixed Load
(Ordinance, Article 84)

建築物の部分	種 別		重 量 (単位 kg/m ²)	備 考	
屋 根	瓦 ぶ き	ふき土がない 場合	屋根面に つき	65	下地及びたるきを含み、 もやを含まない。
		ふき土がある 場合		100	下地及びたるきを含み、 もやを含まない。
	石綿スレ- トぶき	もやに直接ふ く場合		25	もやを含まない。
		その他の場合		35	下地及びたるきを含み、 もやを含まない。
	波形鉄板ぶ き	もやに直接ふ く場合		5	もやを含まない。
	薄鉄板ぶき			20	下地及びたるきを含み、 もやを含まない。
	ガラス屋根			30	鉄製わくを含み、もやを 含まない。
	厚形スレ-トぶ き			45	下地及びたるきを含み、 もやを含まない。
木造の も や	もやの支点間の距離が2m 以下の場合		屋根面に つき	5	
	もやの支点間の距離が4m 以下の場合			10	
天 井	さお縁		天井面に つき	10	
	繊維板張、打上げ板張、合 板張又は金属板張			15	
	木毛セメント板張			20	

		格 縁	30	つり木、受木及びその他の下地を含む。	
		しっくい塗	40		
		モルタル塗	60		
床	木造 の床	板張	15	根太を含む。	
		畳敷	35	床板及び根太を含む。	
		床ばり	張り間が4m以下の場合	10	
			張り間が6m以下の場合	17	
	張り間が8m以下の場合		25		
	コンク リート 造の床 の仕上 げ	板張	20	根太及び大引を含む。	
		フロアリングブロック張	15	仕上げ厚さ1cmごとに、そのcmの数値を乗ずるものとする。	
		モルタル塗、人造石塗及びタイル張	20		
		アスファルト防水層	15	厚さ1cmごとに、そのcmの数値を乗ずるものとする。	
	壁	木造の建築物の壁の軸組		15	柱、間柱及び筋かいを含む。
木造の建築物の壁の仕上げ		下見板張、羽目板張又は繊維板張	10	下地を含み、軸組を含まない。	
		木ずりしっくい塗	35		
		鉄網モルタル塗	65		
		壁面につき			

木造の建築物の小舞壁		85	軸組を含む。
コンク リート 造の壁 の仕上 げ	しっくい塗	17	仕上げ厚さ1cmごとに、そのcmの数値を乗ずるものとする。
	モルタル塗及び人造石塗	20	
	タイル張	20	

Keys

1. Part of a building
2. Kind
3. Weight (unit: kg/m²)
4. Remarks
5. Roof
6. Tile roofing
7. Case with no covering soil
8. Case with covering soil
9. Asbestos slate roofing
10. Case when covered directly on a purline
11. Other cases
12. Corrugated iron sheet roofing
13. Thin iron sheet roofing
14. Glass roofing
15. Thick slate roofing
16. Including groundworks and rafters, but excluding purlines
17. Excluding purlines
18. Including iron frames but excluding purlines
19. Per roof surface
20. Wooden purline
21. Case where the distance between fulcrums of purlines is less than or equal to 2 meters.
22. Case where the distance between fulcrums of purlines is less than or equal to 4 meters.
23. Ceiling
24. Pole frame

25. Fiberboard ceiling, finished board ceiling, plywood ceiling,
or metal sheet ceiling
26. Wood wool cement board ceiling
27. Compartment frame
28. Plastered ceiling
29. Mortar ceiling
30. Including hanging woods, holding woods, and other groundworks
31. Per ceiling surface
(page 86)
32. Floor
33. Wooden floor
34. Board floor
35. Straw matting floor
36. Flooring
37. Case where the span is less than or equal to 4 meters.
38. Case where the span is less than or equal to 6 meters.
39. Case where the span is less than or equal to 8 meters.
40. Finish for concrete floor
41. Board
42. Flooring block
43. Mortar, artificial stone, and tile
44. Asphalt waterproof layer
45. Per floor surface
46. Including baseboards
47. Including floor board and baseboards
48. Including baseboards and sleepers
49. Multiply the number of cm per 1 cm of the finished thickness.
50. Multiply the number of cm per 1 cm of thickness.

51. Wall
52. Axis joints of walls of wooden buildings
53. Finish of walls of a wooden building
54. Clapboarding, wainscotting, or fiberboarding
55. Lath plastered
56. Iron mesh mortar plastered
57. Per wall surface
58. Including pillars, studs, and diagonal beams
59. Including groundworks but excluding axis joints
(page 87)
60. Lath walls of a wooden building
61. Finish for concrete walls
62. Plastered
63. Mortar plastered and artificial stone plastered
64. Tiled
65. Including axis joints

(b) Full cargo load

Full cargo load varies depending on usage and also maintenance conditions of a building. Therefore, as a rule full cargo load must be calculated in accordance with the conditions of a building.

However, for relatively clear full cargo loads for generally used places, numeric values indicated in Table and Figure 62 can be used (Ordinance, Article 85).

When calculating compressive forces exerted by the vertical load of a pillar or pedestal, the numeric values indicated in Table and Figure 62 (except for (5)) can be reduced in accordance with Table and Figure 63.

As for warehouses, even though the calculated value based on the appropriate conditions is less than 400 kg/m^2 , it must be 400 kg/m^2 in the calculation.

Table and Figure 62
Full Cargo Load
(Ordinance, Article 85)

構造計算の対象 室の種類		(イ)	(ロ)	(ハ)
		床の構造計算をする場合 (単位 kg/m^2)	大ばり、柱又は基礎の構造計算をする場合 (単位 kg/m^2)	地震力を計算する場合 (単位 kg/m^2)
(1)	住宅の居室、住宅以外の建築物における寝室又は病室	180	130	60
(2)	事務室	300	180	80
(3)	教室	230	210	110
(4)	百貨店又は店舗の	300	240	130

		売場			
(5)	劇場、映画館、演劇場、観覧場、公会堂、会堂、その他これらに類する用途に供する建築物の客席又は集客室	固定席の場合	300	270	160
		その他の場合	360	330	210
(6)	自動車車庫及び自動車通路		550	400	200
(7)	廊下、玄関又は階段(上の(3)-(5)に連絡する場合)		360	330	210
(8)	屋上広場又はバルコニー	学校百貨店	300	240	130
		その他	180	130	60

Keys

1. Subject of structural calculation
2. Case of the structural calculation for floors (unit: kg/m^2)
3. Case of the structural calculations for girders, pillars, or pedestals (unit: kg/m^2)
4. Case of calculating earthquake force (unit: kg/m^2)
5. Kind of room
6. Dwelling rooms (living rooms, bedrooms, etc.) in a residential house and bedrooms and sickrooms in buildings other than residential buildings.
7. Offices
8. Classrooms
9. Department stores or stores
(page 88)
10. Seating areas and meeting rooms in theatres, movie theatres, entertainment places, museums, public halls, meeting places, and other buildings used for similar purposes.
11. Case where seats are fixed
12. Other cases
13. Automobile garages and automobile driveways
14. Corridors, entrance halls, and stairs (to connect to places indicated in (3) through (5) (8 through 10) above.
15. Rooftop plazas or balconies
16. Schools and department stores
17. Others

Table and Figure 63
 Reduction of Full Cargo Load
 (Ordinance, Article 85)

Note: Apply only to (B) in the above Table and Figure 62.
 However, it cannot apply to (5).

ささえる床の数	2	3	4	5	6	7	8	9以上
積載荷重を減らすために乗すべき数値	0.95	0.9	0.85	0.8	0.75	0.7	0.65	0.6

Keys

1. Number of floors the pillars, girders, and pedestals must support
2. Numeric values to multiply by in order to reduce the full cargo load shown in Table and Figure 62.
3. Over 9

(c) Fallen snow load

Due to weather conditions in Japan, the amount of fallen snow varies greatly place by place. In some regions the snow season also lasts for a long period. In those areas the concerned government agency (refer to Appendix: Definition of Vocabulary) has designated them heavy snow fall areas and strictly enforces provisions related to snow fall. Heavy snow fall areas are mainly located in the Hokkaido, Tohoku, Hokuriku, and San'in regions (Ordinance, Article 86).

- a) Fallen snow load is obtained by multiplying unit weight of fallen snow by the maximum vertical depth of

fallen snow in the area.

(page 89)

b) The unit weight is greater than or equal to 2 kg/m^2 per 1 cm of fallen snow.

In "heavy snow fall areas" (the maximum vertical depth of fallen snow is greater than or equal to 1 meter), the concerned government agency decides the unit weight for the area by regulation. However, in most areas it has been set at 3 kg/m^2 .

c) As a rule the maximum vertical depth of fallen snow is determined in accordance with the situation of the area. But, within "heavy snow fall areas," if the concerned government agency has adopted a specific value for the area by regulation, the value must be used.

d) Fallen snow load can vary depending on the slope of a roof.

e) When snow falls unevenly on the surface of a roof, this condition must be taken into account.

f) Within areas where the custom of removing snow from the roof of a house exists, fallen snow load can be reduced.

g) In the case of buildings for which fallen snow load has been reduced in structural calculations, the actual condition of reduction must be indicated at obvious places in the entrances and exits or in the living rooms.

Table and Figure 64
 Reduction of Fallen Snow Load
 (Ordinance, Article 86, Items 4 and 5)

雪止めのない屋根の勾配(θ)による 低減率 (積雪荷重への乗数)	$30^\circ < \theta \leq 40^\circ$	$40^\circ < \theta \leq 50^\circ$	$50^\circ < \theta \leq 60^\circ$	$60^\circ < \theta$
	0.75	0.5	0.25	0
特定行政庁の指定する 多雪区域における 低減率 (積雪荷重への乗数)	常時荷重としての場合 (長期) : 0.7			
	風圧力又は地震力と同時に採用する場合 (短期) : 0.35			

Keys

1. Reduction rate based on the slope (θ) of a roof without snow guards (Multipliers to fallen snow load)
2. Reduction rate within "heavy snow fall areas" designated by the concerned government agency (Multipliers to fallen snow load)
3. Case of constant loads (long term)
4. Case when adopted simultaneously with wind pressure force or earthquake force (short term)

Table and Figure 65
 Example Displaying Reduction of Fallen Snow Load
 (Ordinance, Article 86, Item 8)

積雪についての注意ノ

この建物は、屋根に1mまで雪がつもっても大丈夫なように造られています。
 もし、1m以上の積雪が見込まれるときは、雪おろしをしないと危険です。
 雪おろしができないときは、ひと先ず避難いたしましょう。

建物管理者名

Key

1. Warning Concerning Snow Fall

This building has been built safe to bear snow falls up to 1 meter on the roof. If a snow fall greater than 1 meter is expected, the building is dangerous unless the snow is removed from the roof. When removal of snow from the roof is impossible, evacuate.

Name of building manager

(page 90)

Table and Figure 66
Example of Heavy Snow Fall Areas

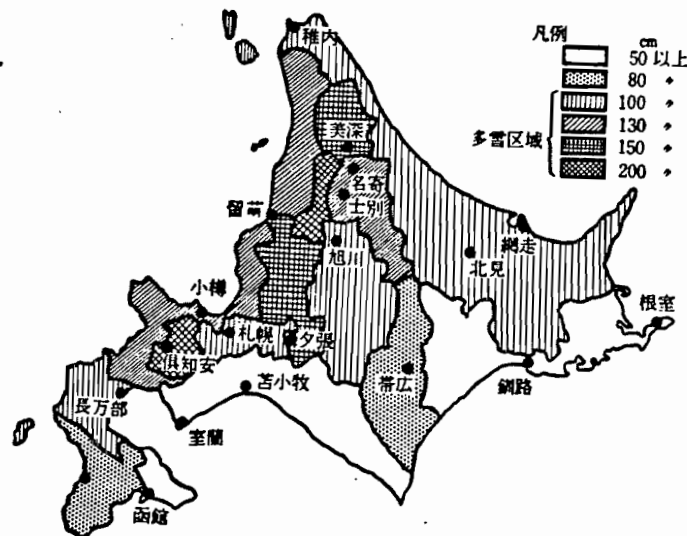

Keys

1. Notes
2. Heavy snow fall areas
3. Greater than or equal to
4. Wakkanai 5. Bifuka 6. Nayoro 7. Shibetsu 8. Abashiri
9. Kitami 10. Nemuro 11. Kushiro 12. Asahikawa 13. Obihiro
14. Yubari 15. Tomakomai 16. Sapporo 17. Rumoi 18. Otaru

19. Kucchian 20. Muroran 21. Oshamanbe 22. Hakodate

Table and Figure 67
The Record for Deepest Snow Falls
(quoted from the Scientific Yearbook)

地 名	最深記録 cm	年 · 月	地 名	最深記録 cm	年 · 月
鹿 兒 島	29	1959.1	高 田	377	1945.2
福 岡	30	1917.12	仙 台	41	1936.2
高 知	9	1963.2	山 形	107	1936.2
鳥 取	129	1947.2	秋 田	117	1974.2
大 阪	18	1907.2	青 森	209	1977.2
京 都	41	1954.1	函 館	91	1977.2
名 古 屋	49	1945.12	旭 川	134	1938.2
高 山	114	1956.2	帯 広	177	1970.3
東 京	46	1883.2	寿 都	189	1945.3
長 野	80	1946.12	札 幌	169	1939.2
福 井	213	1963.1	稚 内	199	1970.2
金 沢	181	1963.1	根 室	92	1933.3
富 山	208	1940.1			

Keys

1. Name of place
2. Deepest record
3. Year, month
4. Kagoshima 5. Fukuoka 6. Kochi 7. Tottori 8. Osaka 9. Kyoto 10. Nagoya 11. Takayama 12. Tokyo 13. Nagano 14. Fukui 15. Kanazawa 16. Toyama 17. Takada 18. Sendai 19. Yamagata 20. Akita 21. Aomori 22. Hakodate 23. Asahikawa 24. Obihiro 25. Suttsu 26. Sapporo 27. Wakkanai 28. Nemuro

(page 91)

(d) Wind pressure force

Wind pressure forces that affect buildings vary depending on the shape and height of a building. The wind

pressure force is obtained by multiplying the wind force coefficient by velocity pressure (Ordinance, Article 87).

a) As a rule the velocity pressure is calculated by the following equation.

Portions whose heights are less than or equal to 16 meters, $q=60\sqrt{h}$

Portions whose heights exceed 16 meters, $q= 120 \sqrt[4]{h}$

Note that q: velocity pressure -- kg/m²

h: height from the ground level -- m

Depending on areas the concerned government agency can reduce the velocity pressure up to 0.6 times (within "heavy snow fall areas," 0.4 times) by regulation based on the standards decided by the Minister of Construction (1952 Construction Ministerial Notification No. 1074; the latest revision, 1978 Construction Ministerial Notification No. 1621).

Also, where there are buildings or shelter-belts that effectively break the wind, the velocity pressure can be reduced up to one half.

Table and Figure 68
Record of Maximum Wind Speeds
(quoted from the Scientific Yearbook)

地名	最大風速 (平均) m/sec	年・月	地名	最大風速 (平均) m/sec	年・月
那覇	49.5 ENE	1945.6	八丈島	44.2 W	1938.10
鹿児島	49.6 SW	1899.8	東京	24.7 S	1965.9
熊本	38.7 E	1902.8	銚子	48.0 SSE	1948.9
福岡	32.5 N	1951.10	金沢	32.8 SSW	1950.9
足摺	35.8 SW	1970.8	仙台	21.7 WSW	1957.12
高知	26.2 S	1970.8	酒田	37.7 WSW	1961.9
室戸岬	69.8 WSW	1965.9	秋田	33.4 W	1902.1
大阪	42.0 S	1934.9	青森	26.2 SW	1959.4
名古屋	37.0 SSE	1959.9	寿都	49.8 SSE	1952.4
富士山	72.5 W	1942.4	札幌	21.1 SW	1956.5
			稚内	26.8 NE	1972.12

Keys

1. Name of place
2. Maximum wind speed (average)
3. Year, month
4. Naha 5. Kagoshima 6. Kumamoto 7. Fukuoka 8. Ashizuri 9. Kochi 10. Cape Muroto 11. Osaka 12. Nagoya 13. Mt. Fuji 14. Hachijo-jima Island 15. Tokyo 16. Chōshi 17. Kanazawa 18. Sendai 19. Sakata 20. Akita 21. Aomori 22. Suttsu 23. Sapporo 24. Wakkanai

b) The wind force coefficient should be, as a rule, obtained by a wind-tunnel test. But, in the case of buildings of clear shape, figures indicated in Table and Figure 69 can be used.

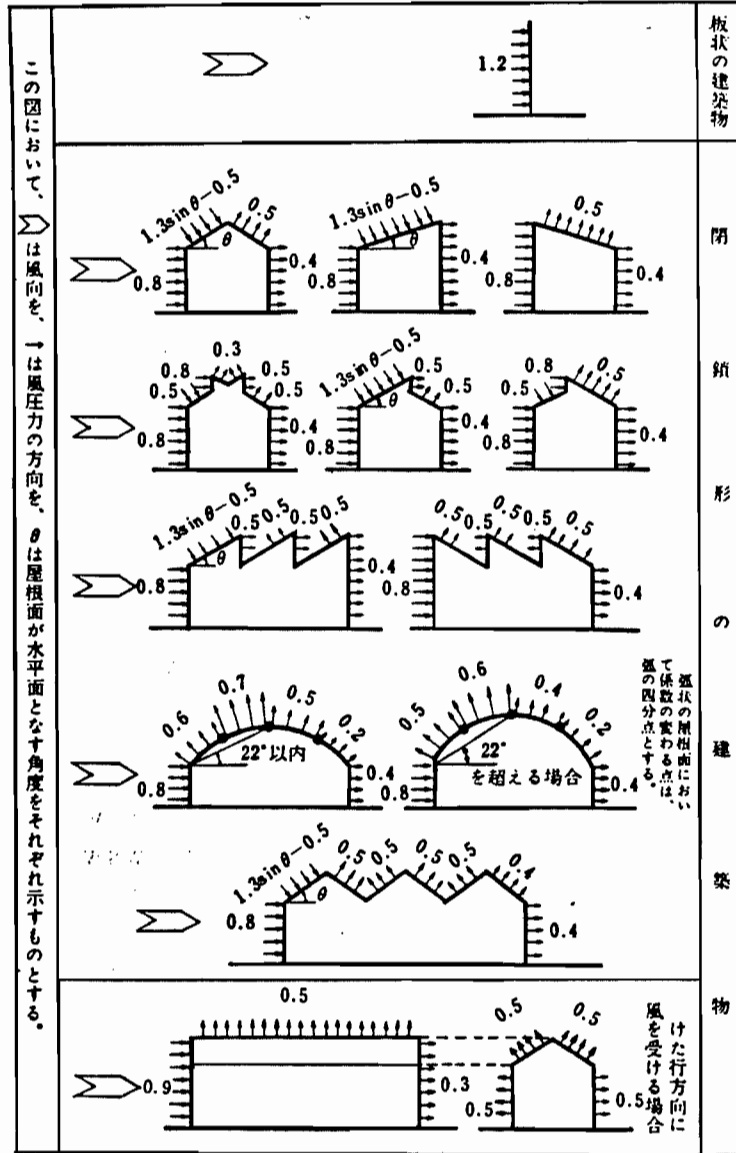

(page 92)

Table and Figure 69
Wind Force Coefficient
(Ordinance, Article 87, Item 4)



風圧の傾斜面にお
 いて係数の変わる点は、
 風の四分点とする。

風を受けた方向に
 風を受ける場合

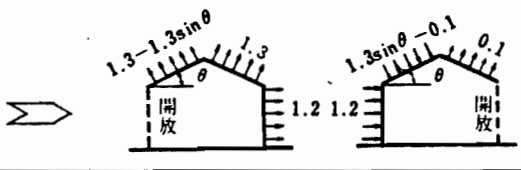
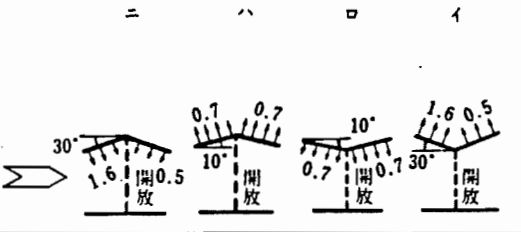
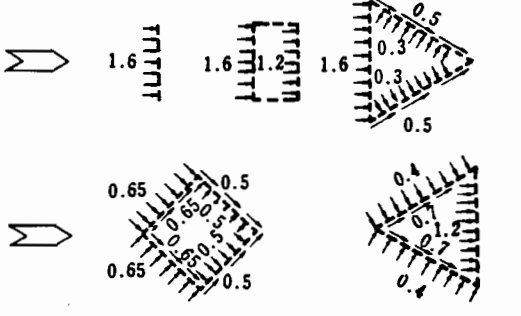
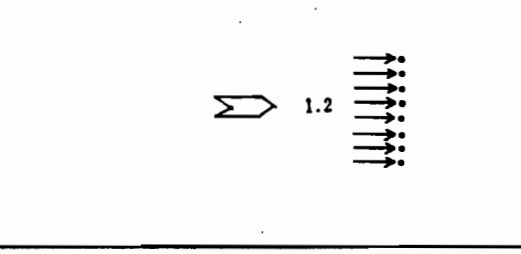
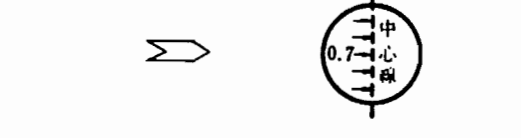
<p>この図において、  は風向を、  は風圧力の方向を、 θ は屋根面が水平面となす角度を示すものとする。</p>		開放形の建築物
		独立上家
		ラチス構造物
		金網その他の網状の構造物
		煙突その他の円筒形の構造物

屋根が水平面となす角度がイ
 と、ロ、ハ又はハとニとのそ
 れぞれの中間の値は、それぞ
 れの風力係数の値に、それぞ
 れの数値を直線的に補間して定
 めるものとする。

次の図は、ラチス及びラチス柱の断
 面を示すものとする。風圧作用面
 として、ラチスの面に対して
 風圧作用面として、ラチスの面に対
 して垂直方向から見たラチス材の見付面積
 を採るものとする。

次の図は、金網等の断面を示
 すものとする。風圧作用面として、金網
 等の面に対して垂直方向から見た
 金網等の見付面積を採るもの
 とする。

Keys

1. In this illustration the following signs indicate the following items.
 - \Rightarrow Direction of wind
 - \rightarrow Direction of wind pressure force
 - θ Angle formed by the roof surface and a horizontal plane
2. Buildings of board shape
3. Closed type buildings
4. Within
5. In case of exceeding
6. In the case of a roof surface of an arch-shape roof, the points where the wind force coefficient changes are every quarter point.
7. Case when a building receives wind in the direction of a crossbeam
(page 93)
8. Open type buildings
9. Open
10. Independent shed
11. When the angle formed by the roof surface and the horizontal plane is in between A and B, B and C, or C and D, the numeric value for wind force coefficient is its equivalent portion between the two coefficients.
12. Latticed structures
13. The illustration on the left is supposed to show the cross section of a latticed pillar or latticed beam. As a surface to be affected by wind pressure, the surface area of lattice

material facing from the direction perpendicular to the surface of the lattice is to be taken.

- 14. Metal mesh and other mesh-type structures
- 15. The illustration on the left is supposed to indicate the cross section of metal mesh. As a surface to be affected by wind pressure, the surface area of metal mesh facing from the direction perpendicular to the surface of the metal mesh is to be taken.
- 16. Smokestacks and other round structures
- 17. Center line

(page 94)
(e) Earthquake force

Japan is one of the world's chief earthquake regions. Our country has suffered from many disastrous earthquakes since ancient times. Consequently, research on earthquake-resistant structures of buildings has been highly developed by pioneer scholars such as Doctors Riki Sano and Tachu Naito. Most buildings with steel frame structures, a direct import from America and Europe, were severely damaged by the Great Kanto Earthquake. [translator's note--an earthquake that struck Tokyo in 1923.] On the other hand, some of the buildings designed by Dr. Tachu Naito were not damaged at all. For this reason his earthquake-resistant structures have received close attention from the Japanese people. This experience has provided the momentum to pull the earthquake-resistant structures from the research laboratory into full practice.

In 1924 a provision concerning the earthquake-resistance of buildings in urban districts was adopted. It is said to be the world's first building code provisions concerning earthquake-resistance.

The present Building Standards Law, legislated in 1950, has inherited the substance of the provision concerning earthquake-resistance in urban district buildings from the old law. It is the so-called horizontal seismic intensity method.

Large-scale buildings have often collapsed in large earthquakes during recent years. As analyses of these

collapses have been made available and the analysis and recording system for the ground vibrations caused by earthquakes has improved, the time came to reconsider the horizontal seismic intensity method. Briefly speaking, it was ascertained that a greater horizontal force was actually working on each story than the earthquake force calculated by the horizontal seismic intensity method. Paradoxically speaking, what had supported the horizontal seismic intensity method and made it function for a long time was a structural surplus provided by the old construction and general structural techniques. However, with the progress of calculation technology and building methods, people began to construct many buildings with no structural surplus and these buildings have suffered in disastrous earthquakes.

Once a problem concerning the horizontal seismic intensity in the horizontal seismic intensity method was clarified, needless to say, it was necessary to revise it.

Before the revision, the earthquake force was calculated by multiplying the weight of each part above ground by the horizontal seismic intensity. On the other hand, in the provision of Article 88 of the revised Ordinance of 1980 effective on 1 June 1981, earthquake force is to be obtained by evaluating ground vibrations caused by earthquakes and the inertial force of a building created by ground vibrations, that is, the horizontal force (level shearing force) created in a building. The earthquake force is calculated by the following method that systematically includes the vibration

characteristics of a building, ground conditions, and other features. (page 95) As for underground portions, the earthquake force is calculated by the horizontal seismic intensity method.

Table and Figure 70
Calculation of Earthquake Forces
(Ordinance, Article 88)

<p>① 地上部分に作用する地震力</p>	<p>② 建築物各部分の地震力 (Qi) = (その部分が支える部分の固定荷重+積載荷重 (多量区域内; +積雪荷重) (W)) × (その部分の高さの地震層せん断力係数 (Ci))</p> <p>$C_i = Z R_1 A_i C_0$</p> <p>Ci: 建築物の一定の高さの地震層せん断力係数 Z: 地域係数 (1.0~0.7) [昭和55年建設省告示第1793号] R1: 建築物固有周期と地盤の関係に基づく地震入力の低減係数 [昭和55年建設省告示第1793号] Ai: 地震層せん断力の高さ方向の分布係数 [昭和55年建設省告示第1793号] C0: ≥0.2 (「軟弱地盤区域」では、≥0.3、必要保有水平耐力計算の場合は、≥1.0)</p>	
<p>③ 地下下する部分に地震力</p>	<p>④ 地下各部分の地震力 (Qi) = (その部分の固定荷重+積載荷重) × (水平震度 (k))</p> <p>$k \geq 0.1 \left(1 - \frac{H}{40}\right) Z$</p> <p>H: その部分の地盤面からの深さ (m) (ただし、≤20) Z: 地域係数</p>	

Keys

1. Earthquake force affecting portions above ground.
2. { Earthquake force for each part of a building (Qi) } = { fixed load + full cargo load (+ fallen snow load within areas of heavy snow fall) borne by that part (W) } x { the earthquake layer shearing force coefficient for the height of that part (Ci) }

190

- Ci: Earthquake layer shearing force coefficient for a part of a building of a certain height.
- Z: Regional coefficient (1.0 - 0.7) (1980 Construction Ministerial Notification No. 1793)
- Rt: Reduction coefficient of earthquake input based on the relationship between the characteristic cycle of a building and ground (1980 Construction Ministerial Notification No. 1793).
- Ai: Distribution coefficient of earthquake layer shearing force in the direction of height (1980 Construction Ministerial Notification No. 1793).
- Co: Co is greater than or equal to 0.2. (Within "soft ground areas," it is greater than or equal to 0.3. In the case of the calculation for horizontal durability that each story is required to retain, it is greater than or equal to 1.0.)

3. Earthquake force affecting underground portions.

$$4. \left\{ \begin{array}{l} \text{Earthquake force for each part of the underground portions } (Q_i) \\ = \{ \text{fixed load} + \text{full cargo load borne by that part} \} \times \{ \text{horizontal seismic intensity } (k) \} \end{array} \right\}$$

H: Depth of the part beneath ground level (m) (but, less than or equal to 20).

Z: Regional coefficient

Keys

1. Area
2. Numeric value for Z
3. Areas other than those in (2) through (4).
4. In Hokkaido, Sapporo, Hakodate, Otaru, Muroran, Kitami, Yubari, Iwamizawa, Abashiri, Tomakomai, Bibai, Ashibetsu, Ebetsu, Akabira, Mikawa, Chitose, Takikawa, Sunagawa, Utashinai, Fukagawa, Furano, Noboribetsu, Eniwa, Date, Sapporo District, Ishikari District, Atsuta District, Hamamasu District, Matsu-
mae District, Kamiiso District, Kameda District, Kayabe District, Yamakoshi District, Hiyama District, Nishi District, Kudoo District, Okushiri District, Setana District, Shimamaki District, Suttu District, Isoya District, Abuta District, Iwanai District, Furuu District, (page 96) Shakotan District, Furubira District, Yoichi District, Sorachi District, Yubari District, Kabato District, Uryu District, Kawakami District (only Higashikagura Town, Kawakami Town, Higashikawa Town, and Biei Town within the jurisdiction of Kawakami Branch), Yufutsu District, Abashiri District, Shari District, Tokoro District, Usu District, and Shiraoui District; in Aomori Prefecture, Aomori, Hirosaki, Kuroishi, Goshokawara, Mutsu, Higashitsugaru District, Nishi-
tsugaru District, Nakatsugaru District, Kitatsugaru District, and Shimokita District; Akita Prefecture; Yamagata Prefecture; in Fukushima Prefecture, Aizuwakamatsu, Kooriyama, Shirakawa, Sukagawa, Kitakata, Iwase District, Minamiaizu District, Kitaaizu District, Yama District, Kawanuma District, Onuma District, and Nishishirakawa District; Niigata Prefecture;

Table and Figure 71
 Numeric Values of Regional Coefficient Z
 (1980 Construction Ministerial Notification No. 1793)

① 地 方	② Z の数値
(1) ③ (2)から(4)までに掲げる地方以外の地方	1.0
④ 北海道のうち 札幌市 函館市 小樽市 室蘭市 北見市 夕張市 岩見沢市 網走市 苫小牧市 美幌市 芦別市 江別市 赤平市 三笠市 千歳市 滝川市 砂川市 歌志内市 深川市 富良野市 登別市 恵庭市 伊達市 札幌郡 石狩郡 厚田郡 浜益郡 松前郡 上磯郡 亀田郡 茅部郡 山越郡 檜山郡 爾志郡 久遠郡 奥 尻郡 瀬棚郡 島牧郡 寿都郡 磯谷郡 虻田郡 岩内郡 古宇 部 積丹郡 占平郡 余市郡 空知郡 夕張郡 樺戸郡 雨竜郡 上川郡 (上川支庁)のうち東神楽町、上川町、東川町及び美瑛町 勇払郡 網走郡 斜里郡 常呂郡 有珠郡 白老郡 青森県のうち 青森市 弘前市 黒石市 五所川原市 むつ市 東津軽郡 西津 軽郡 中津軽郡 南津軽郡 北津軽郡 下北郡 秋田県 山形県 福島県のうち 会津若松市 郡山市 白河市 須賀川市 喜多方市 岩瀬郡 南 会津郡 北会津郡 耶麻郡 河沼郡 大沼郡 西白河郡 新潟県 富山県のうち 魚津市 滑川市 黒部市 下新川郡 石川県のうち 輪島市 珠洲市 鳳至郡 珠洲郡 鳥取県のうち 米子市 倉吉市 境港市 東伯郡 西伯郡 日野郡 島根県 岡山県 広島県 徳島県のうち 美馬郡 三好郡 香川県のうち 高松市 丸亀市 坂出市 善通寺市 観音寺市 小豆郡 香川郡 綾歌郡 仲多度郡 三豊郡 愛媛県 高知県 熊本県 ((3)に掲げる市及び郡を除く) 大分県 ((3)に掲げる市及び郡を除く) 宮崎県	0.9
⑤ 北海道のうち 旭川市 留萌市 稚内市 紋別市 士別市 名寄市 上川郡 (上 川支庁)のうち鷹栖町、当麻町、比布町、愛別町、和寒町、剣淵 町、朝日町、風連町及び下川町 中川郡 (上川支庁) 増毛郡 留萌郡 苫前郡 天塩郡 宗谷郡 枝幸郡 礼文郡 利尻郡 紋 別郡 山口県 福岡県 佐賀県 長崎県 熊本県のうち 八代市 荒尾市 水俣市 玉名市 本渡市 山鹿市 牛深市 宇	0.8

	土市 飽託郡 宇土郡 玉名郡 鹿本郡 芦北郡 天草郡 大分県のうち 中津市 日田市 豊後高田市 杵築市 宇佐市 西国東郡 東国 東郡 速見郡 下毛郡 宇佐郡 鹿児島県 (名瀬市及び大島郡を除く)	
(4)	② 沖縄県	0.7

in Toyama Prefecture, Uozu, Namerikawa, Kurobe, and Shimonishikawa District; in Ishikawa Prefecture, Wajima, Suzu, Fugeshi District, and Suzu District; in Tottori Prefecture, Yonago, Kurayoshi, Sakaiminato, Tohaku District, Saihaku District, and Hino District; Shimane Prefecture; Okayama Prefecture; Hiroshima Prefecture; in Tokushima Prefecture, Mima District and Miyoshi District; in Kagawa Prefecture, Takamatsu, Marugame, Sakaide, Zentsuji, Kannonji, Shozu District, Kagawa District, Ayauta District, Nakatado District, and Mitoyo District; Ehime Prefecture; Kochi Prefecture; Kumamoto Prefecture (except for those listed in (3)); Oita Prefecture (except for those listed in (3)); and Miyazaki Prefecture.

5. In Hokkaido, Asahikawa, Rumoi, Wakkanai, Monbetsu, Shibetsu, Nayoro, Kawakami District (only Takasu Town, Toma Town, Bippu Town, Aibetsu Town, Wassamu Town, Kenbuchi Town, Asahi Town, Furen Town, and Shimokawa Town within the jurisdiction of Kawakami Branch), Nakagawa District (within the jurisdiction of Kawakami Branch), Mashige District, Rumoi District, Tomamae District, Tenshio District, Soya District, Esashi District, Rebun District, Rishiri District, and Monbetsu District; Yamaguchi Prefecture; Fukuoka Prefecture; Saga Prefecture; Nagasaki Prefecture; in Kumamoto Prefecture, Yashiro, Arao, Minamata, Tamana, Hondo, Yamaga, Ushibuka, Uto, (page 97) Hotaku District, Uto District, Tamana District, Kamoto District, Ashikita District, and Amakusa District; in Oita Prefecture, Nakatsu, Hita, Bungotakada, Usuki, Usa, Nishikunisaki District, Higashikunisaki District, Hayami District, Shimoge District, and

Usa District; and Kagoshima Prefecture (except for Nase and Oshima District).

6. Okinawa Prefecture

Table and Figure 72

Computing Methods for Reduction Coefficient of Earthquake Input R_t
(1980 Construction Ministerial Notification No. 1793)

① R_t は、次の表の式によって算出する。ただし、特別の調査又は研究の結果に基づき建築物の振動特性を表す数値が同表の式によって算出した数値を下回ることが確かめられた場合においては、その調査又は研究の結果に基づく数値（この数値が同表の式によって算出した数値に4分の3を乗じた数値に満たないときは、当該数値）まで減じたものとしてすることができる。

② $T < T_c$ の場合	$R_t = 1$
③ $T_c \leq T < 2 T_c$ の場合	$R_t = 1 - 0.2 \left(\frac{T}{T_c} - 1 \right)^2$
④ $2 T_c \leq T$ の場合	$R_t = \frac{1.6 T_c}{T}$

⑤ この表において、 T 及び T_c は、それぞれ次の数値を表す。
 T 次の式によって計算した建築物の設計用一次固有周期（単位 秒）
 $T = h (0.02 + 0.01 a)$
 この式において、 h 及び a は、それぞれ次の数値を表す。
 h 当該建築物の高さ（単位 m）
 a 当該建築物のうち柱及びはりの大部分が鉄骨造である階（地階を除く）の高さの合計の h に対する比
 T_c 建築物の基礎の底部（剛強な支持ぐいを使用する場合にあつては、当該支持ぐいの先端）の直下の地盤の種類に応じて、次の表に掲げる数値（単位 秒）

⑥ 第1種地盤	⑦ 岩盤、硬質砂れき層その他主として第3紀以前の地層によって構成されているもの又は地盤周期等についての調査若しくは研究の結果に基づき、これと同程度の地盤周期を有すると認められるもの	0.4
⑧ 第2種地盤	⑧ 第1種地盤及び第3種地盤以外のもの	0.6
⑨ 第3種地盤	⑨ 腐植土、泥土その他これらに類するもので大部分が構成されている沖積層（盛土がある場合においてはこれを含む）で、その深さがおおむね30m以上のもの	0.8

の、沼沢、泥海等を埋め立てた地盤の深さがおおむね3m以上であり、かつ、これらで埋め立てられてからおおむね30年経過していないもの又は地盤周期等についての調査若しくは研究の結果に基づき、これらと同程度の地盤周期を有すると認められるもの

Keys

1. R_t is computed by the following equations in the table below. However, when the numeric value indicating the vibration characteristics of a building obtained through special investigation or research is lower than the numeric value obtained by computing the following equations in the table, R_t can be lowered up to the numeric value based on the investigation or research. (When this numeric value is less than three fourths of the value based on computation, up to three fourths of the computed value.)

2. The case of T greater than T_c .

3. When T is greater than or equal to T_c , but less than $2T_c$.

4. Case when T is greater than or equal to $2T_c$.

5. In this table T and T_c indicate the following numeric values.

T : The first stage characteristic cycle for design of a building calculated by the following equation below. (unit: seconds)

$$T = h (0.02 + 0.01\alpha)$$

Note that in this equation h and α indicate the following numeric values.

h : the height of the building (unit: meters).

α : the ratio of the total heights of those stories whose pillars and beams are mostly made of steel frame structures (except for basements) to h .

T_c : The numeric values indicated in the table below according to the kind of ground just beneath the bottom part of the pedestals of a building (in the case of pedestals with

strong bearing piles, the ground just beneath the ends of the bearing piles). (unit: seconds)

6. Type 1 ground
7. Rock beds, hard gravels, and other ground composed of mainly pre-Tertiary strata or ground acknowledged by investigation or research to possess an equivalent ground cycle.
8. Type 2 ground
9. Grounds other than Type 1 and Type 2 grounds.
10. Type 3 ground
11. Humus soils, mud, and other alluvia mostly composed of soils similar to these (where the ground is raised, including the banking), whose depth is approximately 30 meters or over; (page 98) reclaimed swamps and muddy places where the depth of filled ground is approximately 30 meters or more and that have been reclaimed for approximately 30 years; or a ground acknowledged by investigation or research to possess a ground cycle equivalent to those.

Table and Figure 73

Computing Method for Distribution Coefficient of Earthquake Layer Shearing Force Coefficient A_i
(1980 Construction Ministerial Notification No. 1793)

- ① A_i は、次の式によつて算出する。ただし、建築物の振動特性についての特別な調査又は研究の結果に基づいて算出する場合においては、その算出によることできる。

$$A_i = 1 + \left(\frac{1}{\sqrt{a_i}} - a_i \right) \frac{2T}{1 + 3T}$$

- ② この式において、 a_i 及び T は、それぞれ次の数値を表す。

a_i : 建築物の A_i を算出しようとする高さの部分が支える部分の固定荷重と積載荷重との和 (建築基準法施行令第86条第2項ただし書の規定によって特定行政庁が指定する多雪区域においては、更に積雪荷重を加える。以下同じ) を当該建築物の地上部分の固定荷重と積載荷重との和で除した数値

T : R_i の算出方法(図表72)に掲げる T の数値

198

Keys

1. A_i is computed by the following equation. However, when A_i is computed on the basis of the results of special investigations or research concerning the vibration characteristics of a building, a value based on the special investigation can be used.
2. In this equation a_i and T indicate the following values.

a_i : the numeric value obtained by dividing the total of fixed load and full cargo load of a portion that is borne by the part whose height is the basis for A_i of a building (within areas of heavy snow fall designated by the concerned government agency according to the provisos of the Ordinance, Article 86, Item 2, add fallen snow load) by the total of fixed load and full cargo load of the portion above ground of the building (within areas of heavy snow fall, add fallen snow load).

T : the numeric value of T described in the computing methods for R_t (Table and Figure 72).

Table and Figure 74

Standards for Designation of "Soft Ground Areas"
(1980 Construction Ministerial Notification No. 1793)

① 特定行政庁が規則で指定する「地盤が著しく軟弱な区域」を定める基準は、地盤が「Rtの算出方法」(図表72)に掲げる第3種地盤に該当する区域とする。

Key

1. The standards by which the concerned government agency designates the "areas whose ground is extremely soft and weak" that are prescribed by regulation are those areas belonging to the Type 3 ground described in the computing method for R_t (Table

and Figure 72).
(page 99)

Table and Figure 75
Famous Earthquakes in Japan

① 発 生 年 月 日 (西 歴)	② 地 震 名 又 は 発 生 地 名	M	③ 被 害 摘 要
④ 元 祿 5 (416)	⑤ 河内		
⑥ 推 古 7 (599)	⑦ 大和	7.0	⑧ 人家破壊
⑨ 天 武 12 (648)	⑩ 土佐など	8.4	⑪ 人家多く倒る。土佐の田苑12km ² 海となる。津波あり
⑫ 天 皇 11 (869)	⑬ 陸奥	8.6	⑭ 三陸地震 津波のため死者1,000人余
⑮ 仁 和 3 (887)	⑯ 京都、及び五畿七道	8.6	⑰ 死傷多し
⑱ 明 応 7 (1498)	⑲ 東海道全般	8.6	⑳ 津波あり、伊勢で家屋1,000棟 死者5,000人 鎌倉で崩死者200
㉑ 慶 長 16 (1611)	㉒ 三陸岬半	8.1	㉓ 崩死1,783 南部津軽で人馬崩死3,000余
㉔ 元 禄 16 (1703)	㉕ 江川及び東海道諸国	8.2	㉖ 壊家20,162軒 死者5,233
㉗ 宝 永 4 (1707)	㉘ 東海道、畿内、南海道、東山、西海両道の一部	8.4	㉙ 壊家29,000 死者4,900 土佐で津波20m
㉚ 文 化 1 (1804)	㉛ 出羽 (象潟)	7.1	㉜ 壊家5,500 死者333 象潟が干潟になる
㉝ 文 政 11 (1828)	㉞ 越後	6.9	㉟ 住家全壊9,808 半壊7,267 焼失1,204 死者1443
㊱ 弘 化 4 (1847)	㊲ 信濃越後	7.4	㊳ 善光寺大地震、壊家34,000 焼失3,500 死者12,000
㊴ 安 政 1 (1854)	㊵ 東海道	8.4	㊶ 流失家屋8,300 焼失300 死者1,000
"	㊷ 西日本	8.4	㊸ 住家全壊10,000 焼失6,000 流失15,000 半壊40,000 死者3,000
㊹ 安 政 2 (1855)	㊺ 江戸	6.9	㊻ 死者7,000 壊焼家14,346
㊼ 明 治 5 (1872)	㊽ 浜田	7.1	㊾ 死者600
24 (1891)	㊿ 美濃	8.4	㊽ 死者7,273 全壊80,000 その他142,177
27 (1894)	㊿ 出羽	7.3	㊾ 死者726
㊿ 明 治 29 (1896)	㊿ 三陸	7.6	㊾ 全、半壊流失10,617 死者27,122 津波の高さ25m
㊿ 大 正 12 (1923)	㊿ 関東南部	7.9	㊾ 全壊128,266 半壊126,233 焼失447,128 流失868 死者99,331 傷者103,733 行方不明43,476
㊿ 昭 和 2 (1927)	㊿ 丹後西北部	7.4	㊾ 全壊4,974 全焼2,651 死者3,017
5 (1930)	㊿ 伊豆北陸	7.0	㊾ 全壊住家2,141 死者259
8 (1933)	㊿ 三陸沖	8.5	㊾ 流失家屋4,086 死者2,986

① 発生年月日 (西 歴)	② 地震名又は 発生地名	M	③ 被 害 摘 要
58 1114 (1939)	⑤ 勿鹿半島	6.6	⑥ 全壊604
18 (1943)	⑥ 鳥取県	7.3	⑦ 全壊7,485 半壊6,158 全焼254 死者1,073 重傷6,153
19 (1944)	⑧ 東南海	8.3	⑨ 死者998 重傷2,135 住家全壊26,130 半壊46,950 流失3,059 全焼11
20 (1945)	⑩ 三河	7.1	⑪ 死者1,961 重傷896 住家全壊5,539 半壊11,706 非住家全壊6,603 半壊9,976
21 (1946)	⑫ 南海	8.1	⑬ 死者1,330 住家全壊9,070 半壊19,204 非住家全壊2,521 半壊4,283 流失1,451 焼失2,598
23 (1948)	⑭ 福井	7.2	⑮ 死者3,895 傷者16,375 全壊35,420 半壊11,449 焼失3,691
27 (1952)	⑯ 十勝沖	8.2	⑰ 家屋全壊815 半壊1,324 流失91 焼失14 死者28 傷者287 行方不明5
36 (1961)	⑱ 長岡	5.2	⑲ 死者5 全壊220 半壊465
37 (1962)	⑳ 宮城県北部	6.5	㉑ 全壊369 半壊1,542
39 (1964)	㉒ 新潟	7.3	㉓ 全壊1,960 半壊6,640
40 (1965)	㉔ 松代群発	⑳ エネルギ (6.3)	
43 (1968)	㉕ えびの(宮崎県)	5.7	㉖ 死者3 全壊368 半壊636
43 (1968)	㉗ 日向灘	7.5	㉘ 全壊2 半壊38 弱い津波
43 (1968)	㉙ 1968十勝沖	7.9	㉚ 死者・行方不明52 全壊673 半壊3,004
47 (1972)	㉛ 八丈島近海	7.0	㉜ (略)
47 (1972)	1972.12.4 ㉝ 八丈島東方沖	7.2	㉞ (略)
48 (1973)	1973.6.17 ㉟ 根室半島沖	7.4	㊱ 傷者26 小津波(根室1.5m)
49 (1974)	㊲ 1974伊豆半島沖	6.9	㊳ 死者・行方不明29 全壊46 半壊125 全半焼7
50 (1975)	㊴ 大分県中部	6.4	㊵ 全壊31 半壊90
53 (1978)	㊶ 伊豆大島近海	7.0	㊷ 死者25、傷者139、全壊94、半壊539
53 (1978)	㊸ 宮城県沖	6.7	㊹ (略)
53 (1978)	㊺ 宮城県沖	7.4	㊻ 死者27、傷者1227、全壊651、半壊5450

Keys

1. Date of occurrence (western year in parentheses).
2. Name of earthquake or place of occurrence
3. Extent of damage and suffering
4. Ingyō [reign name]
5. Kawachi
6. Suiko
7. Yamato
8. Residential houses were destroyed.
9. Tenmu
10. Tosa area
11. Many houses collapsed. Rice fields 12 square km in area absorbed by the sea in Tosa. Tidal waves occurred.
12. Jōgan
13. Mutsu
14. Dead--over 1,000 due to the earthquake and tidal waves in Sanriku.
15. Ninna
16. Kyoto, 5 provinces in the Kinai Region, and 7 major roads.
17. Dead and injured--many.
18. Meiō
19. Whole Tokaido Region
20. Tidal waves occurred. Houses destroyed in Ise--1,000. Dead in Ise--5,000. Dead in Kamakura--200.
21. Keichō
22. Sanriku and Ezo
23. Drowned--1,783. Dead people and dead horses in Nanbu and

Tsugaru--over 3,000.

- 24. Genroku
- 25. Edo and the provinces along the Tokaido Road.
- 26. Houses collapsed--20,162. Dead--5,233.
- 27. Hōei
- 28. Regions of Tokaido, Kinai, Nankaido, and parts of Tōsando and Saikaido Regions.
- 29. Houses collapsed--29,000. Dead--4,900. Tidal waves to a height of 20 meters occurred in Tosa.
- 30. Bunka
- 31. Dewa
- 32. Houses collapsed--5,500. Dead--333. A lagoon became a dry beach.
- 33. Bunsei
- 34. Echigo
- 35. Houses totally collapsed--9,808. Houses partially destroyed--7,267. Houses burnt--1,204. Dead--1,443.
- 36. Kōka
- 37. Shinano and Echigo
- 38. Zenkōji Great Earthquake. Houses collapsed--34,000. Houses burnt--3,500. Dead--12,000.
- 39. Ansei
- 40. Tokaido Region
- 41. Houses swept away--8,300. Houses burnt--300. Dead--1,000.
- 42. Western Japan
- 43. Houses totally destroyed--10,000. Houses burnt--6,000. Houses swept away--15,000. Houses partially destroyed--40,000.

- Dead--3,000.
44. Edo
 45. Dead--7,000. Houses destroyed or burnt--14,346.
 46. Meiji
 47. Hamada
 48. Dead--600.
 49. Mino
 50. Dead--7,273. Houses totally destroyed--80,000. Houses partially destroyed or burnt--142,177.
 51. Dewa
 52. Dead--726.
 53. Sanriku Region
 54. Houses totally destroyed, partially destroyed, or swept away--10,617. Dead--27,122. The tidal waves to a height of 25 meters occurred.
 55. Taishō
 56. Southern part of Kanto (Kanto Great Earthquake)
 57. Houses totally destroyed--128,266. Houses partially destroyed--126,233. Houses burnt--447,128. Houses swept away--868. Dead--99,331. Injured--103,733. Missing people--43,476.
 58. Shōwa
 59. Northwestern part of Tango
 60. Houses totally destroyed--4,974. Houses completely burnt--2,651. Dead--3,017.
 61. Izu and Hokuriku
 62. Residential houses totally destroyed--2,141. Dead--259.
 63. Offshore Sanriku

204

64. Houses swept away--4,086. Dead--2,986.

(page 100)

65. Ojika Peninsula

66. Houses totally destroyed--604.

67. Tottori Prefecture

68. Houses totally destroyed--7,485. Houses partially destroyed--6,158. Houses completely burnt--254. Dead--1,073. Seriously injured--6,153.

69. Eastern Nankaido region

70. Dead--998. Seriously injured--2,135. Residential houses totally destroyed--26,130. Residential houses partially destroyed--46,950. Residential houses swept away--3,059. Houses completely burnt--11.

71. Mikawa

72. Dead--1,961. Seriously injured--896. Residential houses totally destroyed--5,539. Residential houses partially destroyed--11,706. Non-residential buildings totally destroyed--6,603. Non-residential buildings partially destroyed--9,976.

73. Nankaido

74. Dead--1,330. Residential houses totally destroyed--9,070. Residential houses partially destroyed--19,204. Non-residential buildings totally destroyed--2,521. Non-residential buildings partially destroyed--4,283. Houses swept away--1,451. Houses burnt--2,598.

75. Fukui

76. Dead--3,895. Injured--16,375. Houses totally destroyed--35,420. Houses partially destroyed--11,449. Houses burnt--

- 3,691.
77. Offshore Tokachi
78. Houses totally destroyed--815. Houses partially destroyed--1,324. Houses swept away--91. Houses burnt--14. Dead--28. Injured--287. Missing--5.
79. Nagaoka
80. Dead--5. Houses totally destroyed--220. Houses partially destroyed--465.
81. Northern part of Miyagi Prefecture
82. Houses totally destroyed--369. Houses partially destroyed--1,542.
83. Niigata
84. Houses totally destroyed--1,960. Houses partially destroyed--6,640.
85. Matsushiro Series of Toremors
86. Total energy
87. Ebino (Miyazaki Prefecture)
88. Dead--3. Houses totally destroyed--368. Houses partially destroyed--636.
89. The Sea of Hyuga
90. Houses totally destroyed--2. Houses partially destroyed--38. Weak tidal waves occurred.
91. 1968 Tokachi Offshore Earthquake
92. Dead and missing--52. Houses totally destroyed--673. Houses partially destroyed--3,004.
93. Seas around Hachijojima Island
94. (Omitted)

95. Off Eastern Shore of Hachijojima Island
96. Off the shore of Nemuro Peninsula
97. Injured--26. Small tidal waves (to a height of 1.5 meters in Nemuro) occurred.
98. 1974 Earthquake off the Izu Peninsula
99. Dead and missing--29. Houses totally destroyed--46. Houses partially destroyed--125. Houses completely or partially burnt--7.
100. Central part of Oita Prefecture
101. Houses totally destroyed--31. Houses partially destroyed--90.
102. Seas around Izuoshima Island
103. Dead--25. Injured--139. Houses totally destroyed--94. Houses partially destroyed--539.
104. Off the shore of the Miyagi Prefecture
105. Dead--27. Injured--1,227. Houses totally destroyed--651. Houses partially destroyed--5,450.

(page 101)

(3) Permissible stress

As indicated in the principles of structural calculation, in the permissible stress calculation (elastic design), the stress occurring in the section of a part should not exceed the permissible stresses of the materials that compose the section.

Various kinds of materials differ in strength, hardness, tenacity, destruction characteristics, and other aspects in accordance with the nature of the material. Therefore, it is necessary to determine the permissible stress of a material

according to its characteristics. Roughly speaking, short-term stress is determined on the basis of the limit of a material's strength, that is the point at which it gives way; and long-term stress is a reduction of a material's short-term stress that takes into consideration fatigue of the material (Ordinance, Articles 89 through 94).

(a) Timber

Permissible stresses of timber are indicated in Table and Figure 76. Moreover, in the case of timber constantly exposed to moisture, the value will be reduced to 70 percent of that given in Table and Figure 76.

As for the permissible sinking stress of coniferous species, numeric values are determined separately in the direction of the fibers and the direction of force. As for the permissible buckling stress of compressible materials, different numeric values are determined depending on the effective length-and-width ratio (Ordinance, Article 89, Items 4 and 5).

Table and Figure 76
Permissible Stresses of Timber
(Ordinance, Article 89)

⑦ 木材の種類	許容応力度 ①	② 長期応力に対する許容応 力度 (単位 kg/cm ²)			③ 短期応力に対する許容応 力度 (単位 kg/cm ²)		
		④ 圧縮	⑤ 引張り又 は曲げ	⑥ せん断	④ 圧縮	⑤ 引張り又 は曲げ	⑥ せん断
⑧ 針葉樹	⑨ あかまつ、くろまつ 及びべいまつ	75	95	8	⑬ 長期応力に対する圧縮、 引張り、曲げ又はせん断 の許容応力度のそれぞれ の数値の2倍とする。		
	⑩ からまつ、ひば、ひ のき及びべいひ	70	90	7			
	⑪ つが及びべいつが	65	85	7			
	⑫ もみ、えぞまつ、と どまつ、べにまつ、 すぎ、べいすぎ及び スプルース	60	75	6			
⑭ 広葉樹	⑮ かし	90	130	14			
	⑯ くり、なら、よな及 びけやき	70	100	10			

Keys

1. Permissible stress
2. Permissible values for long-term stress (unit: kg/cm²)
3. Permissible values for short-term stress (unit: kg/cm²)
4. Compression
5. Pulling or bending
6. Shearing
7. Kind of wood
8. Coniferous trees
9. Japanese red pine, Japanese black pine, and Oregon pine.
10. Japanese larch, hiba arborvitae, Japanese cypress, and Port Orford cypress.
11. Japanese hemlock, and hemlock spruce.
12. Fir, silver fir, Nemuro fir, red fir, Japanese cedar, Western red cedar, and spruce.

13. Broadleaf trees
14. Oak
15. Japanese chestnut tree, Japanese oak, Japanese beech, and zelkova.
16. Twice the numeric value of the permissible long-term compressive, pulling, bending, or shearing stress.

(page 102)

Table and Figure 77

Special Permissible Stresses of Timber

(Ordinance, Article 94; 1980 Construction Ministerial Notification No. 1797)

② ③ ① ④ ⑤ ⑥ ⑦ ⑧ ⑨ ⑩ ⑪ ⑫ ⑬ ⑭ ⑮ ⑯ ⑰ ⑱ ⑲ ⑳ ㉑ ㉒ ㉓

めりこみの許容応力度は、めりこみ試験の結果に基づき定める場合のほか、その繊維方向と加力方向とのなす角度に応じて次に掲げる数値（基礎ぐい、水槽、浴室その他これらに類する常時湿潤状態にある部分に使用する場合においては、当該数値の70パーセントに相当する数値）とする。

① 10度以下の場合 建築基準法施行令（以下「令」という。）第89条第1項の表に掲げる圧縮の許容応力度の数値

② 10度を超え、70度未満の場合 ①と③とに掲げる数値を直線的に補間した数値

③ 70度以上90度以下の場合 次の表に掲げる数値

⑦ 木材の種類	⑧ 長期応力に対するめりこみの許容応力度 (単位 kg/cm ²)	⑨ 短期応力に対するめりこみの許容応力度 (単位 kg/cm ²)
⑪ ⑫ ⑬ ⑭ 針葉樹 ⑮ ⑯ ⑰ ⑱ 広葉樹	⑮ 30 ⑯ 25 ⑰ 20 ⑱ 40 ㉑ 35	⑲ 長期応力に対するめりこみの許容応力度の数値の2倍とする。

⑲ 圧縮材の座屈の許容応力度は、その有効細長比に応じて、次の表の式によって計算した数値とする。

㉑ $\lambda \leq 30$ の場合	$f_k = f_c$
㉒ $30 < \lambda \leq 100$ の場合	$f_k = f_c (1.3 - 0.01 \lambda)$
㉓ $\lambda > 100$ の場合	$f_k = \frac{0.3 f_c}{\left(\frac{\lambda}{100}\right)^2}$

(23) この表において、 λ 、 f_k 及び f_c は、それぞれ次の数値を表すものとする。
 λ 有効細長比
 f_k 圧縮材の座屈の許容応力度(単位 kg/cm²)
 f_c 令第89条第1項の表(図表76)に掲げる圧縮の許容応力度(単位 kg/cm²)

(24) 繊維方向の許容応力度は、強度試験に基づき定める場合のほか、次の表の数値(基礎ぐい、水槽、浴室その他これらに類する常時湿潤状態にある部分に使用する場合においては、当該数値の70パーセントに相当する数値)とする。

(27) 集成材の樹種	(28) 長期応力に対する許容応力度 (単位 kg/cm ²)			(29) 短期応力に対する許容応力度 (単位 kg/cm ²)		
	(30) 圧縮	(31) 引張り又は曲げ	(32) せん断	(30) 圧縮	(31) 引張り又は曲げ	(32) せん断
(11) あかまつ、くろまつ及びびいまつ	105	145	12	(37) 長期応力に対する圧縮、引張り、曲げ又はせん断の許容応力度のそれぞれの数値の2倍とする。		
(12) からまつ、ひば、ひのき及びべいひ	95	135	11			
(10) (33) 針葉樹 つが及びべいつが	90	125	10			
(34) もみ、えぞまつ、とどまつ、べにまつ、すぎ、べいすぎ及びスプルース	80	115	9			
(35) ラワン	100	130	10			
(14) (36) 広葉樹 みずなら、ふな、けやき、しおじ、たもかば、いたやかえで、にれ	100	150	12			

及びアビトン

- ② ③ りこみの許容応力度は、りこみ試験の結果に基づき定める場合のほか、
 ④ その繊維方向と加力方向とのなす角度に応じて次に掲げる数値（基礎ぐい、水
 ⑤ 槽、浴室その他これらに類する常時湿潤状態にある部分に使用する場合におい
 ⑥ こでは、当該数値の70パーセントに相当する数値）とする。
 ⑦ ⑧ ⑨
 ⑩ ⑪ ⑫ ⑬ ⑭ ⑮ ⑯ ⑰ ⑱ ⑲ ⑳ ㉑ ㉒ ㉓ ㉔ ㉕ ㉖ ㉗ ㉘ ㉙ ㉚ ㉛ ㉜ ㉝ ㉞ ㉟ ㊱ ㊲ ㊳ ㊴ ㊵ ㊶ ㊷ ㊸ ㊹ ㊺ ㊻ ㊼ ㊽ ㊾ ㊿

⑳ 集成材の樹種	㉑ 長期応力に対するめりこみの許容応力度 (単位 kg/cm ²)	㉒ 短期応力に対するめりこみの許容応力度 (単位 kg/cm ²)
㉓ ⑪ あかまつ、くろまつ及びべいまつ	30	
㉔ ⑫ ⑬ ⑭ ⑮ ⑯ ⑰ ⑱ ⑲ ⑳ ㉑ ㉒ ㉓ ㉔ ㉕ ㉖ ㉗ ㉘ ㉙ ㉚ ㉛ ㉜ ㉝ ㉞ ㉟ ㊱ ㊲ ㊳ ㊴ ㊵ ㊶ ㊷ ㊸ ㊹ ㊺ ㊻ ㊼ ㊽ ㊾ ㊿	25	
㉕ ⑳ ㉖ ㉗ ㉘ ㉙ ㉚ ㉛ ㉜ ㉝ ㉞ ㉟ ㊱ ㊲ ㊳ ㊴ ㊵ ㊶ ㊷ ㊸ ㊹ ㊺ ㊻ ㊼ ㊽ ㊾ ㊿	20	㉑ ㉒ ㉓ ㉔ ㉕ ㉖ ㉗ ㉘ ㉙ ㉚ ㉛ ㉜ ㉝ ㉞ ㉟ ㊱ ㊲ ㊳ ㊴ ㊵ ㊶ ㊷ ㊸ ㊹ ㊺ ㊻ ㊼ ㊽ ㊾ ㊿
㉖ ㉗ ㉘ ㉙ ㉚ ㉛ ㉜ ㉝ ㉞ ㉟ ㊱ ㊲ ㊳ ㊴ ㊵ ㊶ ㊷ ㊸ ㊹ ㊺ ㊻ ㊼ ㊽ ㊾ ㊿	40	
㉗ ㉘ ㉙ ㉚ ㉛ ㉜ ㉝ ㉞ ㉟ ㊱ ㊲ ㊳ ㊴ ㊵ ㊶ ㊷ ㊸ ㊹ ㊺ ㊻ ㊼ ㊽ ㊾ ㊿	35	㉑ ㉒ ㉓ ㉔ ㉕ ㉖ ㉗ ㉘ ㉙ ㉚ ㉛ ㉜ ㉝ ㉞ ㉟ ㊱ ㊲ ㊳ ㊴ ㊵ ㊶ ㊷ ㊸ ㊹ ㊺ ㊻ ㊼ ㊽ ㊾ ㊿

㉑ ㉒ ㉓ ㉔ ㉕ ㉖ ㉗ ㉘ ㉙ ㉚ ㉛ ㉜ ㉝ ㉞ ㉟ ㊱ ㊲ ㊳ ㊴ ㊵ ㊶ ㊷ ㊸ ㊹ ㊺ ㊻ ㊼ ㊽ ㊾ ㊿

Keys

1. Permissible stress of timber
2. Sinking
3. Besides cases when the permissible sinking stress is determined on the basis of the results of experiments concerning sinking, the numeric values of permissible sinking stresses are indicated below in accordance with the angle formed by the direction of fiber and the direction of force (when wood is used for water tanks, bathrooms, and other uses where wood is constantly exposed to moisture, the value is equivalent to 70 percent of the value shown).
4. (1) When the angle is less than or equal to 10 degrees, the numeric values of permissible sinking stress are the same as the permissible compressive stress indicated in the table in Ordinance, Article 89, Item 1. (Table and Figure 76)
5. (2) When the angle is greater than 10 degrees but less than 70 degrees, use the value of equivalent proportion between the two values of (1) and (3).
6. (3) When the angle is greater than or equal to 70 degrees but less than or equal to 90 degrees, the numeric values are indicated in the following table.
7. Kind of wood
8. Permissible value for long-term sinking stress (unit: kg/cm²)
9. Permissible value for short-term sinking stress (unit: kg/cm²)
10. Coniferous trees
11. Japanese red pine, Japanese black pine, and Oregon pine.
12. Japanese larch, hiba arborvitae, Japanese cypress, and Port

- Orford cypress.
13. Japanese hemlock, hemlock spruce, fir, silver fir, Nemuro fir, red fir, Japanese cedar, Western red cedar, and spruce.
 14. Broadleaf trees
 15. Oak
 16. Japanese chestnut tree, Japanese oak, Japanese beech, and zelkova.
 17. Twice the numeric value of permissible long-term sinking stress.
 18. Buckling of compressible materials
 19. Permissible buckling stress of compressible materials is obtained by calculating the following equations in accordance with the effective length-and-width ratio.
 20. Case where λ is less than or equal to 30.
 21. Case where λ is greater than 30 but less than or equal to 100.
 22. Case where λ is greater than 100.
- (page 103)
23. In this table, λ , f_k , and f_c indicate the following values.
 - λ : effective length-and-width ratio
 - f_k : permissible buckling stress of compressible materials
(unit: kg/cm²)
 - f_c : permissible compressive stress shown in the table in Ordinance, Article 89, Item 1 (Table and Figure 76). (unit: kg/cm²)
 24. Permissible stress of composite woods
 25. The direction of fiber
 26. Except cases when the permissible stress in the direction of fiber is determined on the basis of experiments concerning

strength, the numeric values are indicated in the following table (where woods are used for water tanks, bathrooms, and other uses where they are constantly exposed to moisture, the value is equivalent to 70 percent of that given below).

27. Kind of composite woods
28. Permissible stress for the long-term (unit: kg/cm²)
29. Permissible stress for the short-term (unit: kg/cm²)
30. Compression
31. Pulling or bending
32. Shearing
33. Japanese hemlock and hemlock spruce
34. Fir, silver fir, Nemuro fir, red fir, Japanese cedar, Western red cedar, and spruce.
35. Lauan
36. Mizunara (a kind of oak), Japanese beech, zelkova, shioji (a kind of sweet osmanthus), tamo, birch, maple, elm, and apiton.
37. Twice the numeric value of the permissible long-term compressive, pulling, bending, or shearing stress.
(page 104)
38. Numeric values are obtained by calculation based on ② in (A)
(19 through 23).
(page 105)
(b) Steel materials et cetera

Permissible stress of steel materials et cetera is provided in Ordinance, Article 90. In addition, it is regulated by the Construction Ministerial Notification based on Ordinance, Article 94.

Table and Figure 78
 Permissible Stress of Steel Material Et Cetera
 (Ordinance, Article 90)

⑧ 種類	② 長期応力に対する許容応力度 (単位 kg/cm ²)				③ 短期応力に対する許容応力度 (単位 kg/cm ²)			
	④ 圧縮	⑤ 引張り	⑥ 曲げ	⑦ せん断	④ 圧縮	⑤ 引張り	⑦ 曲げ	⑦ せん断
⑨ 一般構造用鋼材 溶接構造用鋼材	F/1.5	F/1.5	F/1.5	F/1.5√3	⑬ (長期応力に対する許容応力度) の、それぞれの数値の1.5倍 とする。			
⑩ 黒皮 ボルト	—	F/1.5	—	—				
⑫ 圧上げ	—	F/1.5	—	F/2				
⑬ リベット鋼	—	F/1.5	—	F/2				
⑭ 鋼	F/1.5	F/1.5	F/1.5	F/1.5√3				
⑮ 鉄	F/1.5	—	—	—				
⑧ 種類	② 長期応力に対する許容応力度 (単位 kg/cm ²)			③ 短期応力に対する許容応力度 (単位 kg/cm ²)				
	④ 圧縮	⑤ 引張り		④ 圧縮	⑤ 引張り			
⑰ せん断補強以外	⑱ せん断補強用	⑱ せん断補強用	⑱ せん断補強用	④ 圧縮	⑤ 引張り	⑤ 引張り		
							⑱ せん断補強用	⑱ せん断補強用
⑲ 丸鋼	F/1.5 (ただし、 ≤1,600)	F/1.5 (ただし、 ≤1,600)	F/1.5 (ただし、 ≤2,000)	F	F	F (ただし、 ≤3,000)		
⑳ 異形鉄筋	㉑ 径 ≤ 28mm	F/1.5 (ただし、 ≤2,200)	F/1.5 (ただし、 ≤2,200)	F/1.5 (ただし、 ≤2,000)	F	F	F (ただし、 ≤3,000)	
	㉒ 径 > 28mm	F/1.5 (ただし、 ≤2,000)	F/1.5 (ただし、 ≤2,000)	F/1.5 (ただし、 ≤2,000)	F	F	F (ただし、 ≤3,000)	
㉓ 溶接金網 (鉄線の径 ≥ 4mm)	—	F/1.5	F/1.5	—	F (ただし、 床版用に限る。)	F		

㉔ 注：Fは、鋼材等の種類・品質による許容応力度の基準強度 (kg/cm²) (昭和55年建設省告示第1794号)

Keys

1. Permissible stress
2. Permissible values for long-term stress (unit: kg/cm²)
3. Permissible values for short-term stress (unit: kg/cm²)
4. Compression
5. Pulling
6. Bending
7. Shearing
8. Kind
9. Steel materials for general structural use and steel materials for welding structural use
10. Bolt
11. Black skin
12. Finished
13. Rivet steel
14. Cast steel
15. Cast iron
16. The numeric value for each permissible stress is a value one and a half times the permissible value for long-term stress.
17. Other than for reinforcement against shearing.
18. For reinforcement against shearing.
19. Round steel
20. But
(page 106)
21. Deformed iron bar
22. The diameter is less than or equal to 28 mm.
23. The diameter is greater than 28 mm.
24. Welding metal mesh (the diameter of the metal wire is greater

than or equal to 4 mm.)

25. But, it is limited to those used for floor plates.

26. Note: F is a standard strength for permissible stress depending on the kind and quality of steel materials et cetera (unit: kg/cm²) (1980 Construction Ministerial Notification No. 1794)

Table and Figure 79

Permissible Bearing Stress of Steel Materials Et Cetera and Permissible Buckling Stresses of Steel Compressible Materials and Steel Bending Materials

(1980 Construction Ministerial Notification No. 1799)

① 支 座	② 支座の許容応力度は、次の表の数値 ((1)項及び(3)項において異種の鋼材等が接触する場合においては、小さい値となる数値)とする。	④ 長期応力に対する支座の許容応力度 (単位 kg/cm ²)	⑤ 短期応力に対する支座の許容応力度 (単位 kg/cm ²)
③	支 座 の 形 式		
⑥ (1)	すべり支承又はローラー支承の支承部に支座が生ずる場合その他これに類する場合	1.9F	⑦ 長期応力に対する支座
⑦ (2)	ボルト又はリベットによって接合される鋼材等のボルト又はリベットの軸部に接触する面に支座が生ずる場合その他これに類する場合	1.25F	の許容応力度の数値の1.5倍とする。

<p>② (3)</p>	<p>(1)及び(2)に掲げる場合以外 の場合</p>	$\frac{F}{1.1}$		
<p>⑬ F は、基準強度の数値 (単位 kg/cm²) を表す。</p>				
<p>11 (B) 圧縮材の座屈</p>	<p>⑫ 圧縮材の有効細長比と限界細長比との関係</p>	<p>⑭ 長期応力に対する圧縮材の座屈の許容応力度 (単位 kg/cm²)</p>	<p>⑮ 短期応力に対する圧縮材の座屈の許容応力度 (単位 kg/cm²)</p>	
	<p>⑮ λ ≤ Λ の場合</p>	$F \left\{ \frac{1 - \frac{2}{5} \left(\frac{\lambda}{\Lambda} \right)^2}{\frac{3}{2} + \frac{2}{3} \left(\frac{\lambda}{\Lambda} \right)^2} \right\}$	<p>⑯ 長期応力に対する圧縮材の座屈の許容応力度の数値の1.5倍とする。</p>	
	<p>⑯ λ > Λ の場合</p>	$\frac{18}{65} F \left(\frac{\lambda}{\Lambda} \right)^2$		
<p>⑰ F 基準強度 (単位 kg/cm²) λ 有効細長比 Λ 限界細長比 $\Lambda = \frac{4,800}{\sqrt{\frac{F}{1.5}}}$</p>				
<p>12 (C) 曲げ材の座屈</p>	<p>⑱ 曲げ材の座屈の許容応力度は、次の表の数値とする。ただし、令第90条に規定する曲げの許容応力度の数値(図表78)を超える場合は、その該数値を曲げ材の座屈の許容応力度の数値とする。</p>			
	<p>⑲ 曲げ材の種類及び曲げの形式</p>	<p>⑳ 長期応力に対する曲げ材の座屈の許容応力度 (単位 kg/cm²)</p>	<p>㉑ 短期応力に対する曲げ材の座屈の許容応力度 (単位 kg/cm²)</p>	
<p>㉒ 荷重面内に対称軸を有する 圧延形鋼及びプレートガー</p>		$F \left\{ \frac{2}{3} - \frac{4}{15} \left(\frac{1b}{i} \right)^2 \right\}$		

(1) 鋼その他これに類する組立材で、強軸周りに曲げを受ける場合	$\frac{900}{Af}$ 又は $\frac{lbh}{Af}$ のうち大きい数値	(28) 長期応力に対する曲げ
(26) 鋼管及び箱形断面材の場合、(1)に掲げる曲げ材で弱軸周りに曲げを受ける場合並びにガセットプレートで面内に曲げを受ける場合	$\frac{F}{1.5}$	材の座屈の許容応力度の数値の1.5倍とする。
(27) (3) みぞ形断面材及び荷重面内に対称軸を有しない材の場合	$\frac{900}{(lbh)} \frac{1}{Af}$	
(29) <ul style="list-style-type: none"> † 基準強度 (単位 kg/cm²) l b 圧縮フランジの支点間距離 (単位 cm) i 圧縮フランジと曲げ材のせいの6分の1とからなるT形断面のウェブ軸周りの断面2次半径 (単位 cm) C 次の式によって計算した修正係数 (2.3を超える場合には2.3とする) $C = 1.75 - 1.05 \left(\frac{M_2}{M_1} \right) + 0.3 \left(\frac{M_2}{M_1} \right)^2$ <p style="margin-left: 20px;">(この式において、M₂及びM₁は、それぞれ座屈区間端部における小さい方及び大きい方の強軸周りの曲げモーメントを表すものとする。)</p> <ul style="list-style-type: none"> A 限界細長比 h 曲げ材のせい (単位 cm) Af 圧縮フランジの断面積 (単位 cm²) 		

Keys

1. Bearing stress
 2. Permissible bearing stresses are indicated in the following table (when different kinds of steel materials et cetera are in contact in the case of 6-(1) and 8-(3), the permissible bearing stress will be the smaller of the alternatives).
 3. Form of bearing pressure
 4. Permissible long-term value for bearing stress (unit: kg/cm²)
 5. Permissible short-term value for bearing stress (unit: kg/cm²)
 6. (1) Where bearing stress occurs in a sill of a slide sill or roller sill, and other similar cases.
 7. (2) Where bearing stress occurs on a surface in contact with the axial part of bolts or rivets of steel materials et cetera that are connected by bolts or rivets, and other similar cases.
 8. (3) Cases other than 6-(1) and 7-(2).
 9. The numeric value are one and a half times the permissible long-term bearing stress.
- (page 107)
10. F indicates numeric value of standard strength (unit: kg/cm²)
 11. Buckling of compressible materials
 12. Relationship between the effective length-and-width ratio and the limited length-and-width ratio of compressible materials.
 13. Permissible long-term buckling stress of compressible materials (unit: kg/cm²)
 14. Permissible short-term buckling stress of compressive materials (unit: kg/cm²)
 15. Where λ is less than or equal to Λ .

16. Where λ is greater than Λ .
17. The numeric values are one and a half times the permissible long-term buckling stress of compressible materials.
18. F: standard strength (unit: kg/cm²)
 λ : effective length-and-width ratio
 Λ : limit length-and-width ratio
19. Buckling of bending materials
20. Numeric values of permissible buckling stress of bending materials are indicated in the following table. However, when the value indicated below exceeds the numeric values of permissible bending stress provided by Ordinance, Article 90 (Table and Figure 78), those provided by Article 90 are the values for permissible buckling stress of bending materials.
21. Kind of bending materials and form of bending
22. Permissible long-term buckling stress of bending materials (unit: kg/cm²)
23. Permissible short-term buckling stress of bending materials (unit: kg/cm²)
24. (1) When rolled section steel or plate girders possessing an axis of symmetry within the surface that receives load, or other similar assembling materials receive a bending force around its strong axis.
- (page 108)
25. The greater of $F \left\{ \frac{2}{3} - \frac{4}{15} \frac{(\frac{1b}{i})^2}{C\Lambda^2} \right\}$ or $\frac{900}{(\frac{1bh}{Af})}$.
26. (2) The case of steel pipe and box-shaped section materials when the bending materials listed in 24-(1) receive a bending

force around their weak axes, and when a gasetto plate receives a bending force within its surface.

27. (3) The case of channel section material and other bending materials that do not possess an axis of symmetry within the surface that receives load.

28. The numeric values are one and a half times the permissible long-term buckling stress of bending materials.

29. F: Standard strength (unit: kg/cm²)

ib: The distance between fulcrums of compressive flanges (unit: centimeters)

i: Sectional second degree radius of the circumference of the webb axis of a T-shaped section formed by a compressive flange and one-sixth of the height of a bending material (unit: centimeters)

C: Amended coefficient calculated by the following equation (when it exceeds 2.3, it must be 2.3).

$$C = 1.75 - 1.05 \left(\frac{M_2}{M_1} \right) + 0.3 \left(\frac{M_2}{M_1} \right)^2$$

In this equation, M₂ and M₁ indicate the smaller and the greater bending moments around the strong axis at the ends of the portion buckled respectively.

Λ: limit length-and-width ratio

h: height of bending material (unit: centimeters)

A_f: sectional area of a compressive flange (unit: cm²)

Table and Figure 80
 Standard Strength for Permissible Stress of Steel Materials
 Et Cetera
 (1980 Construction Ministerial Notification No. 1794)

① 鋼材等の種類及び品質		② 基準強度 (単位 kg/cm ²)	
③ 一般構造用鋼材	S S 41 S M 41 S M A 41 S T K 41 S T K R 41	⑤ 鋼材の厚さ ≤ 40mm	2,400
		⑤ 鋼材の厚さ > 40mm	2,200

④ 溶接構造用鋼材	S S 50	⑤ 鋼材の厚さ ≤ 40mm	2,800
		⑤ 鋼材の厚さ > 40mm	2,600
	S M 50 S M 50 Y S M A 50 S T K 50 S T K R 50	⑤ 鋼材の厚さ ≤ 40mm	3,300
		⑤ 鋼材の厚さ > 40mm	3,000
		S M 53	⑤ 鋼材の厚さ ≤ 40mm
		⑤ 鋼材の厚さ > 40mm	3,400
S S 55		3,800	
⑥ ポ ル ト		⑦ 黒 皮	1,900
		⑦ 仕 上 げ	2,400
⑨ リ ベ ッ ト 鋼			2,400
⑩ 鋳 鋼			2,400
⑪ 鋳 鉄			1,500
⑫ 丸 鋼	S R 24 S R R 24		2,400
	S R 30 S R R 40		3,000
⑬ 異 形 鉄 筋	S D 24 S D R 24		2,400
	S D 30		3,000
	S D 35		3,500
	S D 40		4,000
⑭ 溶接金網 (鉄線の径 ≥ 4mm)			3,000

⑮ S S 41、S S 50及びS S 55は、日本工業規格(以下「JIS」という)G 3101-1976(一般構造用圧延鋼材)に定めるS S 41、S S 50及びS S 55又はこれ

Keys

1. Kind and quality of steel materials et cetera
 2. Standard strength (unit: kg/cm²)
 3. Steel materials for general structural use
 4. Steel materials for welding structural use
 5. Thickness of steel materials
- (page 109)
6. Bolt
 7. Black skin
 8. Finished
 9. Rivet steel
 10. Cast steel
 11. Cast iron
 12. Round steel
 13. Deformed iron bar
 14. Welding metal mesh (the diameter of the iron wire is greater than or equal to 4 mm).
 15. SS41, SS50, and SS55 indicate the SS41, SS50, and SS55 specified in Japan Industrial Standards (JIS) G3101-1976 (rolled steel materials for general structural use) or other steel materials of a quality better than or equal to them. (page 110)
SM41, SM50, SM50Y, and SM53 indicate the SM41, SM50, SM50Y, and SM53 specified in JIS G3106-1977 (rolled steel materials for welding structural use) or other steel materials of a quality better than or equal to them. SMA41 and SMA50 indicate the SMA41 and SMA50 specified in JIS G3114-1977 (weather-resistant hot rolled steel materials for welding structural use) or other steel materials of a quality better than or

equal to them. STK41 and STK50 indicate the STK41 and STK50 specified in JIS G3444-1977 (carbon steel pipe for general structural use) or other steel materials of a quality better than or equal to them. STKR41 and STKR50 indicate the STKR41 and STKR50 specified in JIS G3466-1975 (square-shaped steel pipe for general structural use) or other steel materials of a quality better than or equal to them. SR24, SR30, SD24, SD30, SD35, and SD40 indicate the SR24, SR30, SD24, SD30, SD35, and SD40 specified in JIS G3112-1975 (bar steel for reinforced concrete structure) or other steel materials of a quality better than or equal to them. SRR24, SRR40, and SDR 24 indicate the SRR24, SRR40, and SDR24 specified in JIS G3117-1975 (regenerated bar steel for reinforced concrete structure) or other steel materials of a quality better than or equal to them.

(c) Concrete

As a rule the permissible stress of concrete is determined by the standard strength (F) for design. As for the permissible sticking stress, values verified by experiments and calculations can be used.

Where concerned government agencies have decided the upper limit of standard strength (F) for design by regulations based on regional characteristics, the value for F must be determined on the basis of those regulations (Ordinance, Article 91).

Table and Figure 81
Permissible Stress of Concrete

① 長期応力に対する許容応力度 (単位 kg/cm ²)				② 短期応力に対する許容応力度 (単位 kg/cm ²)			
③ 圧縮	④ 引張り	⑤ せん断	⑥ 付着	③ 圧縮	④ 引張り	⑤ せん断	⑥ 付着
F/3			⑦ (軽量骨材の場合は、6)				⑧ (長期応力に対する許容応力度のそれぞれ2倍の数値とする。)

Keys

1. Permissible long-term stress (unit: kg/cm²)
2. Permissible short-term stress (unit: kg/cm²)
3. Compression
4. Pulling
5. Shearing
6. Sticking
7. (In the case of light-weight aggregate, 6)
8. The numeric values are twice the permissible long-term stress.

(d) Welding

Table and Figure 82

Permissible Stress and Standard Strength for Vital Sections of Welded Joint

(Ordinance, Article 92; 1980 Construction Ministerial Notification No. 1794)

② 作業の方法		④ 長期応力に対する許容応力度 (単位 kg/cm ²)				⑤ 短期応力に対する許容応力度 (単位 kg/cm ²)				
		⑥ 圧縮	⑦ 引張り	⑧ 曲げ	⑨ せん断	⑥ 圧縮	⑦ 引張り	⑧ 曲げ	⑨ せん断	
① 許容応力度	⑩ 自動溶接装置等の設置その他建設大臣が高度の品質確保を認めた作業条件の場合	F/1.5		F/1.5√3		④ (長期応力に対する許容応力度のそれぞれの数値の2倍とする。)				
	⑪ 突合せ	F/1.5√3								
	⑫ その他	0.9F/1.5		0.9F/1.5√3						
	⑬ 突合せ	0.9F/1.5√3								
⑭ 溶接部の許容応力度の基準強度は、次の表の数値（異なる種類又は品質の鋼材を溶接する場合においては、接合される鋼材の基準強度のうち小さい値となる数値）とする。										
⑮ 基準強度 (F)	⑯ 鋼材の種類及び品質		⑰ 基準強度 (単位 kg/cm ²)							
	⑱ 一般構造用鋼材	SS41 SM41	⑲ 鋼材の厚さ ≤ 40mm		2,400					
		SMA41 STK41	⑲ 鋼材の厚さ > 40mm		2,200					
		⑳ 溶接構造用鋼材	SM50 SM50Y SMA50	⑲ 鋼材の厚さ ≤ 40mm		3,300				
			STK50 STKR50	⑲ 鋼材の厚さ > 40mm		3,000				
		SM53	⑲ 鋼材の厚さ ≤ 40mm		3,600					
			⑲ 鋼材の厚さ > 40mm		3,400					
	㉒ 丸	鋼		SR24 SRR24	2,400					
				SR30 SRR40	3,000					
	㉓ 異形鉄筋			SD24 SDR24	2,400					
SD30				3,000						
SD35				3,500						
SD40				4,000						
㉔ 注：JISの表示の意味については、(図表80) 参照。										

Keys

1. Permissible stress
2. Welding method
3. Form of joint
4. Permissible long-term stress (unit: kg/cm²)
5. Permissible short-term stress (unit: kg/cm²)
6. Compression
7. Pulling
8. Bending
9. Shearing
(page 111)
10. In case of installation of automated welding equipment and so forth or other welding methods certified by the Minister of Construction to maintain high quality of work.
11. End to end
12. Others
13. Other cases
14. The numeric values are twice the permissible long-term stress.
15. Standard strength (F)
16. The standard strength for permissible stress of a welded joint is indicated in the following table (when different kinds or qualities of steel materials are welded, the lowest standard strength of the welded steel materials).
17. Kind and quality of steel materials.
18. Standard strength (unit: kg/cm²)
19. Steel materials for general structural use
20. Steel materials for welding structural use

21. Thickness of steel material
22. Round steel
23. Deformed iron bar
24. Note: As for description of JIS, refer to Table and Figure 80.
(page 112)
(e) Connection by high-strength bolts

There are two kinds of connections by high-strength bolts: friction connection and pulling connection. In the case of the former, the permissible stress is the permissible shearing stress on the axial section, and in the case of the latter, the permissible pulling stress on the axial section (Ordinance, Article 92-2; 1980 Construction Ministerial Notification No. 1795).

Table and Figure 83
Permissible Stress and Standard Tension of
Connection by High-Strength Bolts

① 摩 擦 接 合	④ 種類	② 長期応力に対する許容せん断 応力度, f_{so} (単位 kg/cm^2)	③ 短期応力に対する許容せん断 応力度, f_{so} (単位 kg/cm^2)
	⑤ 一面せん 断	⑦ $0.3 T_o$ (基準張力)	⑥ (長期応力に対する許容せん 断応力度の数値の2倍とす る。)
⑥ 二面せん 断	⑦ $0.6 T_o$ (基準張力)		
	⑧ 高力ボルトが、引張り力とせん断力を同時に受けるときの摩擦接合部の高力ボ ルトの軸断面に対する許容せん断応力度 (f_{st}) は、下式による。 $f_{st} = f_{so} \left(1 - \frac{\sigma}{T_o} \right)$ (ここで、 σ は、高力ボルトに加わる外力による 引張応力度 (kg/cm^2) ⑩ 基準張力 (T_o) は、下表による。		
	⑪ 高力ボルトの品質	⑬ 高力ボルトの締付ボ ルト張力(単位 kg/cm^2)	⑭ 高力ボルトの基準張力 (単位 kg/cm^2)
	⑫ 高力ボルトの種類		
	(1) 1 種	⑮ 4,000以上	4,000
	(2) 2 種	⑮ 5,000以上	5,000
	(3) 3 種	⑮ 5,350以上	5,350
	⑯ 1種、2種及び3種は、日本工業規格 (以下「JIS」という) B1186-1979 (摩擦接合用高力六角ボルト・六角ナット・平座金のセット)に定める1種、 2種及び3種又はこれらと同等以上の品質を有する摩擦接合用高力ボルト、 ナット及び座金の組合せを表す。		

⑳ 引 張 接 合	⑪ 高力ボルトの品質	㉑ 長期応力に対する引張 りの許容応力度 (単位 kg/cm^2)	㉒ 短期応力に対する引張りの 許容応力度 (単位 kg/cm^2)
	㉓ 上掲、基準張力の表中 (1)項	2,500	㉔ 長期応力に対する引張りの 許容応力度の数値の1.5倍 とする。
	㉓ 上掲、基準張力の表中 (2)項	3,100	
㉓ 上掲、基準張力の表中 (3)項	3,300		

Keys

1. Friction connection
2. Permissible long-term shearing stress (f_{so}) (unit: kg/cm^2)
3. Permissible short-term shearing stress (f_{so}) (unit: kg/cm^2)
4. Kind
5. One-surface shearing
6. Two-surface shearing
7. (Standard tension)
8. The numeric values are twice the permissible long-term shearing stress.
9. The permissible shearing stress on the axial section of a high-strength bolt used in for a friction connection (f_{st}) when the high-strength bolt is simultaneously subjected to tensile force and shearing force is obtained by computing the following equation.

$$f_{st} = f_{so} \left(1 - \frac{\sigma_t}{T_0} \right)$$

Note that σ_t indicates the pulling stress due to an external force imposed on the high-strength bolt (unit: kg/cm^2).
10. Standard tension (T_0) is based on the following table.
11. Quality of high-strength bolt
12. Kind of high-strength bolt
13. Tension of a clamping bolt of a high-strength bolt (unit: kg/cm^2).
14. Standard tension of high-strength bolt (unit: kg/cm^2).
15. Type 1
16. Type 2
17. Type 3

18. Greater than or equal to
19. Type 1, Type 2, and Type 3 indicate the Type 1, Type 2, and Type 3 specified in JIS B1186-1979 (sets of high-strength hexagonal bolts, hexagonal nuts, and flat metal washers for use in friction connections) and other sets of high-strength bolts, nuts, and metal washers for use in friction connections of a quality better than or equal to them.

(page 113)

20. Pulling connection
21. Permissible long-term stress (unit: kg/cm²)
22. Permissible short-term pulling stress (unit: kg/cm²)
23. Item (1) of the standard tension in the table above.
24. Item (2) of the standard tension in the table above.
25. Item (3) of the standard tension in the table above.
26. The numeric values are one and a half times the permissible long-term pulling stress.

(f) Ground and pedestal piles

The permissible stresses of ground and pedestal piles are determined by a ground investigation using one (or more) of the ground investigation methods listed in (a) through (i) below, and based on Tables and Figures 85 and 86 (Ordinance, Article 93; 1971 Construction Ministerial Notification No. 111; the latest revision, 1978 Construction Ministerial Notification No. 1623).

- (a) Boring investigation
- (b) Standard interpenetration test
- (c) Static interpenetration test
- (d) Been test

- (e) Soil quality test
- (f) Physical probing
- (g) Flatboard loading test
- (h) Pile driving test
- (i) Pile loading test

When characteristics of the ground are clearly known and the type of ground is one of those listed in Table and Figure 84, the numeric value indicated in Table and Figure 84 can be used.

Table and Figure 84
Permissible Stress of Ground
(Ordinance, Article 93)

③ 地盤	① 長期応力に対する許容応力度 (単位 t/m ²)	② 短期応力に対する許容応力度 (単位 t/m ²)
④ 岩盤	100	⑭ 長期応力に対する許容応力度の それぞれの数値の2倍とする。
⑤ 固結した砂	50	
⑥ 土丹盤	30	
⑦ 密実な礫層	30	
⑧ 密実な砂質地盤	20	
⑨ 砂質地盤	5	
⑩ 堅い粘土質地盤	10	
⑪ 粘土質地盤	2	
⑫ 堅いローム層	10	
⑬ ローム層	5	

Keys

1. Permissible long-term stress (unit: t/m²)
2. Permissible short-term stress (unit: t/m²)
3. Ground
4. Rock bed

5. Compacted sand
6. Red clay ground
7. Dense conglomerate layer
8. Dense sandy ground
(page 114)
9. Sandy ground
10. Hard clay ground
11. Clay ground
12. Hard loam layer
13. Loam layer
14. The numeric values are twice the permissible long-term stress.

Table and Figure 85
 Method for Determining Permissible Stress of Ground
 (1971 Construction Ministerial Notification No. 111)

② 長期応力に対する地盤の許容応力度を定める場合	③ 短期応力に対する地盤の許容応力度を定める場合
(1) $q_a = \frac{1}{3} (\alpha C N_c + \beta \gamma_1 B N_r + \gamma_2 D_f N_q)$	$q_a = \frac{2}{3} (\alpha C N_c + \beta \gamma_1 B N_r + \frac{1}{2} \gamma_2 D_f N_q)$
(2) $q_a = q_t + \frac{1}{3} N' \gamma_2 D_f$	$q_a = 2q_t + \frac{1}{3} N' \gamma_2 D_f$

④ この表において、 q_a 、 α 、 β 、 C 、 B 、 N_c 、 N_r 、 N_q 、 γ_1 、 γ_2 、 D_f 、 q_t 及び N' はそれぞれ次の数値を表わすものとする。

⑤ q_a 地盤の許容応力度 (単位 1平方メートルにつきトン)

⑥ α 及び β 基礎荷重面の形状に応じて次の表に掲げる係数

⑦ 基礎荷重面の形状 ⑩ 係数	⑧ 円形	⑨ 円形以外の形状
α	1.3	$1.0 + 0.3B/L$
β	0.3	$0.5 - 0.1B/L$

⑪ この表において、 B 及び L は、それぞれ基礎荷重面の短辺又は短径及び長辺又は長径の長さを表すものとする。

⑫ C 基礎荷重面下にある地盤の粘着力 (単位 1平方メートルにつきトン)

⑬ B 基礎荷重面の短辺又は短径 (単位 メートル)

⑭ N_c 、 N_r 及び N_q 地盤の内部摩擦角に応じて次の表に掲げる支持力係数

(18) 支持力係数	(15) 内部摩擦角 0度	(16) 5度	(16) 10度	(16) 15度	(16) 20度	(16) 25度	(16) 28度	(16) 32度	(16) 36度	(16) 40度 以上
Nc	5.3	5.3	5.3	6.5	7.9	9.9	11.4	20.9	42.2	95.7
Nr	0	0	0	1.2	2.0	3.3	4.4	10.6	30.5	114.0
Nq	3.0	3.4	3.9	4.7	5.9	7.6	9.1	16.1	33.6	83.2

(19) この表に掲げる内部摩擦角以外の内部摩擦角に応じたNc、Nr及びNqは、表に掲げる数値をそれぞれ直線的に補間した数値とする。

(20) γ_1 基礎荷重面下にある地盤の単位体積重量又は水中単位体積重量 (単位 1立方メートルにつきトン)

(21) γ_2 基礎荷重面より上方にある地盤の平均単位体積重量又は水中単位体積重量 (単位 1立方メートルにつきトン)

(22) Df 基礎に近接した最低地盤面から基礎荷重面までの深さ (単位 メートル)

(23) q_t 平板載荷試験による降伏荷重度の2分の1の数値又は極限応力度の3分の1の数値のうちいずれか小さなもの (単位 1平方メートルにつきトン)

(24) N' 基礎荷重面下の地盤の種類に応じて次の表に掲げる係数

(19) 係数	(25) 地盤の種類 砂質土地盤のうち 密実なもの	(26) 砂質土地盤 (密実なものを除く)	(27) 粘性土地盤
N'	12	6	3

Keys

1. The permissible stress of the ground is determined on the basis of equations (1) and (2) in the table below.
 2. To determine the permissible long-term stress of the ground.
 3. To determine the permissible short-term stress of the ground.
 4. In this table q_a , α , β , C , B , N_c , N_r , N_q , γ_1 , γ_2 , D_f , q_t , and N' indicate the following values.
 5. q_a : permissible stress of the ground (unit: t/m^2)
 6. α and β : coefficients indicated in the following table in accordance with the shape of the loading surface of pedestals.
 7. Shape of the loading surface of pedestals
 8. Round shape
 9. Shapes other than round
 10. Coefficient
 11. In this table B and L indicate the longer diameter or dimension and the shorter diameter or dimension of the loading surface of a pedestal respectively.
 12. C : viscosity of the ground just beneath the loading surface of a pedestal (unit: t/m^2)
 13. B : the shorter dimension or diameter of the loading surface of a pedestal (unit: meters).
 14. N_c , N_r , and N_q indicate bearing force coefficients shown in the following table in accordance with the internal friction angle of the ground.
- (page 115)
15. Internal friction angle
 16. Degrees
 17. Greater than or equal to

239

18. Bearing force coefficient
19. In case of N_c , N_r , and N_q based on internal friction angles other than those listed in this table, the numeric value is proportionate to the known values.
20. γ_1 : unit volume weight or underwater unit volume weight of the ground beneath the loading surface of a pedestal (unit: t/m^3)
21. γ_2 : average unit volume weight or underwater unit volume weight of the ground above the loading surface of a pedestal (unit: t/m^3)
22. D_f : the distance between the lowest ground level close to the pedestal and the loading surface of the pedestal (unit: meters)
23. q_t : the smaller numeric value of one-half of the load at which the ground gives way in a flatboard loading test or one-third of the limit stress (unit: t/m^2).
24. N' : coefficient indicated in the following table below. Depends on the type of soil beneath the loading surface of the pedestal.
25. Type of ground
26. Among sandy soils, the dense type
27. Sandy soils (except for the dense type)
28. Clay soils

Table and Figure 86
 Method of Determining Permissible Bearing Force of Pedestal Piles
 (1971 Construction Ministerial Notification No. 111)

	③ 長期応力に対する地盤の許容支持力	④ 短期応力に対する地盤の許容支持力
(A)	$R_a = \frac{1}{3} R_u$	$R_a = \frac{2}{3} R_u$
(B)	$R_a = \frac{F}{5S+0.1}$	$R_a = \frac{2F}{5S+0.1}$

(C)	$R_a = q_p A_p + \frac{1}{3} R_f$	$R_a = 2q_p A_p + \frac{2}{3} R_f$
(D)	$R_a = q'_a A_p + \frac{1}{3} R_f$	$R_a = q'_a A_p + \frac{2}{3} R_f$

⑤ この表で、 R_a 、 R_u 、 F 、 S 、 q_p 、 A_p 、 R_f 、 q_a 及び q'_a は、それぞれ次の数値を表す。
 R_a 地盤の許容支持力 (単位、t)
 R_u くい载荷試験による極限支持力 (単位、t)
 F ハンマーの打撃エネルギー (単位、tm)
 S 基礎ぐいの最終貫入量 (単位、m)
 q_p 基礎ぐいの先端の地盤の許容応力度 (次の表の基礎ぐいの場合はそれぞれの式により計算した数値とし、その他の基礎ぐいではその基礎ぐいの施工方法に応じて、くい载荷試験の結果に基づき建設大臣の認めた数値とする。) (単位、t/m²)

⑥ 基礎ぐいの種類	⑦ 基礎ぐいの先端の地盤の許容応力度
⑧ 打込みぐい	$q_p = \frac{30\bar{N}}{3}$
⑨ セメントミルク工法による埋込みぐい	$q_p = \frac{20\bar{N}}{3}$
⑩ ベント工法、リバースサーキュレーション工法又はアースドリル工法による場所打ちぐい (以下「ベント工法等による場所打ちぐい」という。)	$q_p = \frac{15\bar{N}}{3}$

⑪ この表で、 \bar{N} は、基礎ぐいの先端付近の地盤の標準貫入試験による打撃回数の平均値 (60を超えるときは60とする。) (単位、回) を表す。

⑫ A_p 基礎ぐいの先端の有効断面積 (単位、m²)
 R_f 次の式により計算した基礎ぐいと其の周囲の地盤 (軟弱な粘性土地盤、軟弱な粘性土地盤の上部にある砂質土地盤及び地震時に液状化するおそれのある地盤を除く。以下この表において同じ。) との摩擦力 (単位、t)
 $R_f = (\frac{1}{5} \bar{N}_s L_s + \frac{1}{2} \bar{q}_u L_c) \phi$

⑬ この式で、 \bar{N}_s 、 L_s 、 \bar{q}_u 、 L_c 及び ϕ は、それぞれ次の数値を表す。
 \bar{N}_s 基礎ぐいの周囲の地盤のうち砂質土地盤の標準貫入試験による打撃回数 (打込みぐいでは50を超えるときは50とし、セメントミルク工法による埋込みぐい又はベント工法等による場所打ちぐいでは25を超えるときは25とする。)の平均値 (単位、回)
 L_s 基礎ぐいが其の周囲の地盤のうち砂質土地盤に接する長さの合計 (単位、m)
 \bar{q}_u 基礎ぐいの周囲の地盤のうち粘性土地盤の一軸圧縮強度 (打込みぐいでは20を超えるときは20とし、セメントミルク工法による埋込みぐい又はベント工法等による場所打ちぐいでは10を超えるときは10とする。)の平均値 (単位、t/m²)

- L_c 基礎ぐいとその周囲の地盤のうち粘性土地盤に接する長さの合計 (単位、m)
 ψ 基礎ぐいの周の長さ (単位、m)
- (14) 第2の表に掲げる式により計算した長期応力に対する地盤の許容応力度 (単位、 t/m^2)
 q'_s 第2の表に掲げる式により計算した短期応力に対する地盤の許容応力度 (単位、 t/m^2)

- (15) 摩擦ぐいの許容支持力は、次の表の(一)項若しくは(二)項の式 (基礎ぐいの周囲の地盤に軟弱な粘性土地盤、軟弱な粘性土地盤の上部にある砂質土地盤又は地震時に液状化するおそれのある地盤が含まれる場合は(二)項の式) により計算した基礎ぐいとその周囲の地盤との摩擦力又はくい体の許容応力のうちいずれか小さなものとする。

	(16) 長期応力に対する基礎ぐいとその周囲の地盤との摩擦力	(17) 短期応力に対する基礎ぐいとその周囲の地盤との摩擦力
(A))	$R_a = \frac{1}{3} R_u$	$R_a = \frac{2}{3} R_u$
(B))	$R_a = \frac{1}{3} R_r$	$R_a = \frac{2}{3} R_r$

(18) この表において、 R_a は基礎ぐいとその周囲の地盤との摩擦力を、 R_u 及び R_r は支持ぐいの欄の数値を表す。

Keys

1. The choice between the following two methods of the permissible bearing force of pedestal piles depends on the kind of pedestal piles.
2. (1) The permissible bearing force of a bearing pile is the smaller of the permissible bearing force of the ground or the permissible stress of a pile itself calculated according to the following equations (A) through (D). (Where the ground around the pedestal piles consists of either soft clay soils or soft clay underneath sandy soils and for soil that could liquefy in an earthquake, use equations (C) and (D) only.)
3. Permissible long-term bearing force of the ground
4. Permissible short-term bearing force of the ground
(page 116)
5. In this table R_a , R_u , F , S , q_p , A_p , R_F , q_a , and q'_a indicate the following values.

R_a : permissible bearing force of the ground (unit: t)

R_u : limit of bearing force obtained by the pile loading test
(unit: t)

F : striking energy of a hammer (unit: tm)

S : the depth of the final interpenetration of a pedestal pile
(unit: m)

q_p : the permissible stress of the ground at the end of a pedestal pile. (In the case of the pedestal piles listed in the following table, the numeric values for q_p are obtained by computing the equations in the table below. As for other kinds of pedestal piles, a numeric value is decided by the Minister of Construction based on the result of pile loading

tests according to the construction method of the pedestal pile.) (unit: t/m³)

- 6. Kind of pedestal pile
- 7. Permissible stress of the ground at the end of a pedestal pile.
- 8. Driven pile
- 9. Pile buried by the cement milk construction method.
- 10. Pile driven by the benoto, reverse circulation, or earth drill construction methods (hereafter these piles will be referred to as "piles driven by the reverse circulation construction method et cetera.")
- 11. In this table \bar{N} represents the average value of the number of impacts in the standard interpenetration test of the ground around the end of a pedestal pile. (When \bar{N} exceeds 60, it is 60.) (unit: repetitions)
- 12. A_p : effective sectional area of the end of a pedestal pile (unit: m²)

RF: friction force arising between a pedestal pile and the ground around it obtained by computing the following equation (except for the soft clay soils, or soft clay underneath sandy soils and for other soils that could liquefy in an earthquake. Hereafter in this table this exceptional condition applies to all cases of the ground around a pedestal pile.) (unit:t)

- 13. In this equation \bar{N}_s , L_s , \bar{q}_u , L_c , and ϕ represent the following values.

\bar{N}_s : the average number of impacts in the standard interpenetration test of sandy soils in the ground around pedestal piles. (In the case of driven piles, when the average number

of impacts exceeds 50 repetitions, it is 50. In the case of piles buried by the cement milk construction method and piles driven by the reverse circulation construction method et cetera, when the average number of impacts exceeds 25, it is 25.)

(unit: repetitions)

Ls: the total length of a pedestal pile in contact with sandy soil in the ground around it (unit: meters).

\bar{q}_u : the average value of the one-axis-compression strength of clay soil in the ground around the pedestal pile. (In the case of driven piles, when the average value exceeds 20, it is 20. In the case of piles buried by the cement milk construction method and piles driven by the reverse circulation construction method et cetera, when the average number exceeds 10, it is 10.) (unit: t/m²)

(page 117)

Lc: the total length of pedestal pile in contact with clay soil in the ground around it (unit: meters).

ϕ : the circumference of a pedestal pile (unit: meters).

14. q_a: permissible long-term stress of the ground calculated from the equations listed in the second table of Table and Figure 86 (unit: t/m²).

q'_a: permissible short-term stress of the ground calculated from the equations listed in the second table of Table and Figure 86 (unit: t/m²).

15. (2) The permissible bearing force of a friction pile is the smaller of the friction force arising between a pedestal pile and the ground around it or the permissible stress of a pile itself calculated according to the following equations (A)

- and (B). (Where the ground around the pedestal pile contains soft clays or soft clays beneath sandy soil and/or soil that could liquefy in an earthquake, use the equation of (B) only.)
16. Friction force arising between a pedestal pile and the ground around it to the long-term stress.
 17. Friction force arising between a pedestal pile and the ground around it to the short-term stress.
 18. In this table R_a represents the friction force arising from a pedestal pile and the ground around it, and R_u and R_F indicate the values shown in method (1) (5 and 12).

(4) Material strength

Material strength is used in calculations of the horizontal durability retained by each story. Material strength is supposed to be the calculated maximum stress (Ordinance, Articles 95 through 99).

(a) Timber

Table and Figure 87
Material Strength of Timber

248

(Ordinance, Article 95; 1980 Construction Ministerial Notification No. 1799)

① 織	② 種 類	③ 材料強度 (単位 kg/cm ²)		
		④ 圧 縮	⑤ 引張り又は曲げ	⑥ せん断
材 質	⑦ ⑧ 赤かまつ、くろまつ及びべいまつ	225	285	24
	⑨ 白かまつ、ひば、ひのき及びべいひ	210	270	21
	⑩ かつが及びべいつが	195	255	21
	⑪ とも、もろまつ、とこまつ、へにまつ、すき、べいすき及びスダース	180	225	18
向	⑫ かし	270	390	42
	⑬ くり、なら、ぶな及びけやき	210	300	30
⑭ 合89条2項(かた木のこみ栓等)・3項(基礎ぐい等)の特例が準用される。				
⑮ 材 成 材 強 の 度	⑯ 材 成 材 強 の 度	⑰ かりこみの材料強度 = 3 × (長期応力に対するかりこみの許容応力度)		
	⑱ 材 成 材 強 の 度	⑲ 圧縮材の座屈の材料強度 = (短期応力に対する圧縮材の座屈の許容応力度)		
⑮ 材 成 材 強 の 度	⑱ 材 成 材 強 の 度	⑳ 繊維方向の材料強度 = 3 × (長期応力に対する許容応力度)		
	㉑ 材 成 材 強 の 度	㉑ かりこみの材料強度 = 3 × (長期応力に対するかりこみの許容応力度)		
⑮ 材 成 材 強 の 度	㉒ 材 成 材 強 の 度	㉒ 圧縮材の座屈の材料強度 = (短期応力に対する圧縮材の座屈の許容応力度)		
	㉓ 材 成 材 強 の 度	㉓ 繊維方向の材料強度 = 3 × (長期応力に対する許容応力度)		

Keys

1. Direction of fiber
2. Kind
3. Material strength (unit: kg/cm²)
4. Compression
5. Pulling or bending
6. Shearing
7. Coniferous trees
8. Japanese red pine, Japanese black pine, and Oregon pine
9. Japanese larch, hiba arborvitae, Japanese cypress, and Port Orford cypress.

10. Japanese hemlock and hemlock spruce
 11. Fir, silver fir, Nemuro fir, red fir, Japanese cedar, Western red cedar, and spruce.
- (page 118)
12. Broadleaf trees
 13. Oak
 14. Japanese chestnut tree, Japanese oak, Japanese beech, and zelkova.
 15. The special provisions of Item 2 (nails in hardwoods et cetera) and Item 3 (pedestal piles et cetera) of Ordinance, Article 89 apply with necessary modifications.
 16. Sinking and buckling of compressible materials
 17. Material strength for sinking = $3 \times$ (permissible long-term sinking stress)
Material strength for buckling of compressible materials = (permissible short-term buckling stress of compressible materials)
 18. Material strength of composite woods
 19. Material strength in the direction of fiber = $3 \times$ (permissible long-term stress)
Material strength for sinking = $3 \times$ (permissible long-term sinking stress)
Material strength for buckling of compressible materials = (permissible short-term buckling stress of the compressible materials)

(b) Steel materials et cetera

Table and Figure 88

Material Strength of Steel Materials Et Cetera

(Ordinance, Article 96; 1980 Construction Ministerial Notification No. 1794)

① 種 類	② 材料強度 (単位 kg/cm ²)			
	③ 圧 縮	④ 引 張 り	⑤ 曲 げ	⑥ せん断
⑦ 一般構造用鋼材 溶接構造用鋼材 (*)	F	F	F	$F/\sqrt{3}$
⑧ 高力ボルト	—	F	—	$F/\sqrt{3}$
⑨ ボ ル ト	⑩ 黒 皮	—	F	—
	⑪ 仕 上 げ	—	F	$\frac{3F}{4}$
⑫ リベット鋼	—	F	—	$\frac{3F}{4}$
⑬ 鋳 鋼	F	F	F	$F/\sqrt{3}$
⑭ 鋳 鉄	F	—	—	—

① 種 類	② 材料強度 (単位 kg/cm ²)		
	③ 圧 縮	④ 引 張 り	⑤ せん断補強以外 ⑥ せん断補強用
⑰ 鋼・異形鉄筋 (*)	F	F	F (ただし、 $\leq 3,000$)

⑱ 溶接金網 (鉄線の径 ≥ 4 mm)	—	⑲ F (ただし、床版用に限る)	F
---------------------------	---	------------------	---

⑳ 基準強度 (F) は、許容応力度の基準強度の表 (図表80) に掲げる数値に同じ。
ただし、同表のJISに定められた上記※欄のものについては、実況に応じた数値又は、同表の数値の1.1倍以下の数値とすることができる。

㉑ 付：高力ボルトの材料強度の基準強度 (昭和55年建設省告示第1795号)

㉒ 高力ボルトの品質	㉓ 基準強度 (単位 1平方センチメートルにつきキログラム)
F8T	6,400
F10T	9,000
F11T	9,500

㉔ F8T、F10T及びF11Tは、JIS B 1186-1979 (摩擦接合用高力六角ボルト・六角ナット・平座金のセット) に定めるF8T、F10T及びF11T又はこれらと同等以上の品質を有する高力ボルトを表す。

Keys

1. Kind
2. Material strength (unit: kg/cm²)
3. Compression
4. Pulling
5. Bending
6. Shearing
7. Steel materials for general structural use
Steel materials for welding structural use
8. High-strength bolt
9. Bolt
10. Black skin
11. Finished
12. Rivet steel
13. Cast steel
14. Cast iron
15. Other than for reinforcement against shearing
16. For reinforcement against shearing
17. Round steel and deformed iron bars
18. But
(page 119)
19. Welding metal mesh (the diameter of the metal wire is greater than or equal to 4 mm).
20. But, it is limited to those used for floor plates.
21. Standard strength (F) is same as the numeric values indicated in the table of standard strength for permissible stress (Table and Figure 80). However, as for steel materials specified in JIS and marked with the symbol (*) in the table above,

F can be a numeric value based on the actual situation or up to 1.1 times the numeric values shown in the table (Table and Figure 80).

22. Appendix: Standard Strength for Material Strength of High-Strength Bolts

(1980 Construction Ministerial Notification No. 1795)

23. Quality of high-strength bolt

24. Standard strength (unit: kg/cm²)

25. F8T, F10T, and F11T indicate the F8T, F10T, and F11T specified in JIS B1186-1979 (sets of high-strength hexagonal bolts, hexagonal nuts, and flat metal washers for use in friction connections) or other sets of high-strength bolts, nuts, and metal washers possessing a quality better than or equal to them.

Table and Figure 89
 Material Strength for Bearing Pressure and
 Buckling of Compressible Materials
 (1980 Construction Ministerial Notification No. 1799)

① 支圧の材料強度	② 「短期応力に対する支圧の許容応力度」に準じて定める。	
③ 圧縮材の座屈の材料強度	④ 圧縮材の有効細長比と限界細長比との関係	⑤ 圧縮材の座屈の材料強度 (単位 1平方センチメートルにつきキログラム)
	⑥ $\lambda \leq \Lambda$ の場合	$F \left\{ 1 - \frac{2}{5} \left(\frac{\lambda}{\Lambda} \right)^2 \right\}$
	⑦ $\lambda > \Lambda$ の場合	$\frac{3}{5} F \frac{1}{\left(\frac{\lambda}{\Lambda} \right)^2}$
	⑧ F: 材料強度の基準強度 (kg/cm ²)	
	⑨ λ : 有効細長比	
	⑩ Λ : 限界細長比	
	$\Lambda = \frac{4,800}{\sqrt{\frac{F}{1.5}}}$	

Keys

1. Material strength for bearing pressure
2. It is determined in accordance with "permissible short-term bearing pressure stress."
3. Material strength for buckling of compressible materials
4. Relationship between the effective length-and-width ratio and the limit length-and-width ratio
5. Material strength for buckling of compressible materials (unit: kg/cm²).
6. Case where λ is less than or equal to Λ .
7. Case where λ is greater than Λ .
8. F: standard strength of material strength (kg/cm²)
9. λ : Effective length-and-width ratio

(page 120)

10. A: limit length-and-width ratio

(c) Concrete

Table and Figure 90
Material Strength of Concrete
(Ordinance, Article 97)

① 材料強度 (単位 kg/cm ²)			
② 圧縮	③ 引張り	④ せん断	⑤ 付着
F	F/10		21 ④ (軽集骨材の場合、18)
⑦ F は設計基準強度、令91条2項 (特定行政庁が定める上限の数値) が準用される。			

Keys

1. Material strength (unit: kg/cm²)
2. Compression
3. Pulling
4. Shearing
5. Striking
6. (In the case of light-weight aggregate, 18)
7. F is standard strength for design and Ordinance, Article 91, Item 2 (the upper limit of standard strength determined by the concerned government agency) applies with necessary modifications to F.

(d) Welding

Table and Figure 91

Material Strength of Vital Section of Welded Joint
(Ordinance, article 98; 1980 Construction Ministerial Notification No. 1794)

① 作業の方法	② 継目の形式	③ 材料強度 (単位 kg/cm ²)		
		④ 圧縮	⑤ 引張り	⑥ 曲げ
⑧ 自動溶接装置等の設置その他建設大臣が高度の品質確保を認めた作業条件の場合	⑨ 突合せ	F		$F/\sqrt{3}$
	⑩ その他	$F/\sqrt{3}$		$F/\sqrt{3}$
⑪ その他の場合	⑨ 突合せ	0.9F		$0.9F/\sqrt{3}$
	⑩ その他	$0.9F/\sqrt{3}$		$0.9F/\sqrt{3}$

⑫ 基準強度 (F) は、許容応力度の基準強度の表に掲げる数値に同じ。
ただし、同表のJISに定められた上記※欄のものについては、実況に応じた数値、又は、同表の数値の1.1倍以下の数値とすることができる。

Keys

1. Welding method
2. Form of joint
3. Material strength (unit: kg/cm²)
4. Compression
5. Pulling
6. Bending
7. Shearing
8. Cases involving the installation of automated welding equipment or other mechanical devices, and other welding methods certified by the Minister of Construction to maintain a high quality of work.
9. End to end
10. Others
11. Other cases

Chapter 3: Standards for the Construction of Healthy Cities:

(Regulations from the Architectural Standards Law)

SECTION I Part 1 Standards for Urban Structures

1. 1) Urban Planning and Architecture

Cities are a collection of people and buildings. It is there that people work, study, play, rest, live and carry on many different types of lifestyles. It may be said that in cities the base of these lifestyles is concentrated into a smaller area. Accordingly cities are a complicated combination political, economic, commercial, cultural, and consumer oriented factors. And so it is the goal of urban planning to provide order to the base of these lifestyles, and to see to it that the functions necessary to maintain the city will work smoother and on an ever more sophisticated level in the future. In this case the core urban function (area of greatest emphasis) must be seen as the life of its citizens, and not, as many past views have held, the economic functions of the city. The past tendancey to view urban planning soley from the economic functions of a city must be reflected upon. In fact this tendancey can be seen as one of the origins of present urban problems.

When establishing an urban plan it is necessary to properly grasp the political, economic, social , cultural and all aspects of the city's development over the next few years and few decades, and also to clearly know what form the city should take in the future. Then, based on the composition of the population (population, population by occupation, population density by area), business composition (industry, commerce agriculture, service industries, etc.) estimates of the scope of urbanization must be established so that a plan for the most rational use of land can be drawn up.

In this fashion the Land Use Plan (use of land and land capacity) will become the base of the Urban Plan. Using this as a base, concrete plans can be laid for roads, railroads, harbors, borderland, water supply and sewage, waste disposal facilities and all public facilities; also following this regulations can be established for the use and shape of individual structures.

2) Urban Planning Law and the Architectural Standards Law

Along with roads, bulidings are the most important factor in the composition of the style of a city. Also, since building are affixed to the land, it limits the use of the land and fixes the high level utilization of the proprty. To put it in another way, it is buildings that realize the Land Use Plan and create the form of a city. Accordingly, bulidings have a very important place in the execution of any urban plan. The Urban Planning Law and the Architectural Standards Law are the two pillars of regulations concerning cities and architecture.

The Urban Planning Law (old law) was promulgated in 1920 along with its sister law the Urban Land Building Law, precursor of the present Architectural Standards Law. Then in 1968 the law was completely revised (new law) to become the basis for regulations concerning the method of execution, costs, areas and districts authorization, limits on land use and buildings in specially designated areas, expropriation of land needed for each individual project, for the Urban Plan and urban planning operations.

The Architectural Standards Law supports the Urban Planning Law determining concrete limits to areas and districts required under the Urban Plan, as well as places restrictions on the form of buildings to be erected in town areas. Since these regulations deal with buildings as agroup, and are intended to preserve order for the structures as a

group, so these are called "all-embracing collective regulations (group regulations) or urban planning regulations.

Concerning these collective regulations, we will learn more about them in part two and beyond, but in the main it will be the following sort of information.

- (1) Regulations concerning the system of land use
- (2) Regulations concerning building lot and shape
 - a. Relation between lot and roads
 - Collective b. Proportion of building foundation area to lot area
 - Regulations and capacity proprotion
 - c. Height

- (3) Regulations concerning Fire Prevention Area Sysytem

Collective regulations, as the name suggests, are applicable to city land or future city land. The third chapter of the Architectural Standards Law deals with the lots, strucutre and building facilities of bulidings in urban plan areas, this chapter may be applied only to those areas.(Law 41-2). The contents of the restrictions on area and district in the realization of an urban plan are determined by the Architectural Standards Law to supplement the Urban Planning Law, and are as follows:

(1) Area use (First class restricted residential area, second class restricted residential area, residential area, neighboring commercial area, commercial area, semi-industrial area, industrial area, restricted industrial area)

(2) Special use area (special industrial area, educational-cultural area, small business-shop area, office area, amusement-recreation area, tourist area, special business area, public welfare area)

(3) Advanced area

- (4) High use area
- (5) Special town area
- (6) Fire prevention area, semi-fire prevention area
- (7) Beautiful sights area

In the determining of these areas and districts the opinion of generally related cities, towns, and villages will be heard before the city, county or prefectural governor authorizes them through the procedures determined in the Urban Planning Law. The procedures determined by the Urban Planning Law referred to here pass first through a discussion by the local deliberative assembly for urban planning (established in urban and local prefectures) and then in general receive authorization from the Minister of Construction (Urban Law chap. 2 part 2).

In addition to areas and districts from the Urban Planning Law that are also covered under the Architectural Standards Law there are:

- (1) Scenic areas

These areas are authorized when it is recognized as necessary for preserving the scenic beauty of a city.

- (2) Harbor supervision areas

These areas are authorized for the supervision and operation of harbors.

- (3) Parking lot and equipment areas, special preservation area for historic sites, special preservation areas for suburban borderlands, (Tokyo and Osaka), preservation areas for borderlands (urban planning district), transportation industry areas.

These are all areas in which it is possible to receive authorization. Also, in addition to these it is possible to limit the construction of buildings in order to provide land for urban facilities or town development projects covered under urban planning, like parks,

green areas, public squares, and other facilities and land organization projects.

SECTION II

Part 2: Building Restrictions for Roads

1. (1) Architecture and Roads

You cannot erect buildings in a place without roads. There are even roads for single houses in the middle of the mountains, in the old days post towns formed around joints in the roadways. Roads run up and down in cities, and lined up along them are buildings. It is safe to say that urban areas are formed of buildings and roads, and that the relation between buildings and roads is an intimate one.

Also, in addition to their original goal of providing communication lanes, roads in cities have come to have many different meanings. In other words:

(1) They contribute to the architectural environment in their role as empty spaces, thus providing paths for wind, lighting, and sunlight.

(2) They provide pipes and lines for water, gas, electrical supply, telephone and telegraph facilities.

(3) They have a role as evacuation routes in times of emergency, they help in fire-fighting, and they prevent the spread of fires.

(4) They are useful in ordering town districts and heighten the efficiency of urban functions.

Even in the Architectural Standards Law's collective regulations there are many limits provided for emphasizing roads and road related issues from this same point of view. Also, even with issues not directly connected to roads, eg. area usage, open space areas, etc. at the time of authorization for these things the present and future dispositions of roads will play a large role.

2. (2) Defintion of Roads

There are many regulations pertaining to roads in the third chapter of the Architectural Standards Law (buildings within urban planning areas). Accordingly, it is necessary to first define roads as the term is used in the Architectural Standards Law (Law 42)

The term road as used in the Architectural Standards Law has the condition of being wider than 4 meters as viewed from the perspective of sub-section (1). In other words, the following which are more than 4 meters wide will be considered roads (Law 41 part 1):

a. Roads in the Road Law (Law 41 part 1 #1)

The so-called public road; interstate, prefectural, town or village roads all come under this heading.

b. Roads defined by the Urban Planning Law, Land Zone Ordering Law, or the laws referring to the old Residential Land Composition Projects, or the Urban Redevelopment Law (Law 41 part 1 #2)

Roads determined by the Urban Planning, Urban Planning projects, zone ordering projects once completed come under the aegis of the Road Law, and receive their authorization by application to the preceding item a..

c. Roads that already existed when it came to application of the law's regulations.

Since it those roads within Urban Planning areas that come under the regulations of Chapter 3, when the decision on the Urban Plan area has been made, all roads of width more than 4 meters, with no distinction between public and private, will be considered roads.

d. Roads in Project plans (Law 41 part 1 #4)

Roads in project plans for new road construction or replacing old roads according to either the Road Law or the Urban Planning Law will

require special authorization from a Special Administrative Branch if the expected execution interval for the project is less than two years.

d. Private Roads Receiving Authorization from a Special Administrative Branch (Law 42 part 1 # 5)

Those who wish to build private roads that do not come under either the Road Law or the Urban Planning Law must receive authorization from a Special Administrative Branch as to the positioning of said road (within the limits applied by Order 144-3's standards).

The above a, b, c are already existing roads, whereas d and e are roads to be built in the future, but regardless of this, they all must meet the condition of being 4 meters or wider. The "expected roads" noted in districts under a District Organizing Plan or a Corridor Road Plan will be viewed as roads under Law 42 part 2, and the regulations of Law 44 will be applied to them. See (4) Building Restrictions within Roads.

However, from the point of view of the development and organization of urban roads in our nations cities, it is difficult to imagine negating all to the already existing roads that do not satisfy the 4 meters or above requirement, and since there are many cases of buildings crowded close to each other with little chance of reorganization, a relief clause exists for roads less than 4 meters that have the authorization of a Special Administrative Branch (Law 42 parts 2 and 3).

In this case two lines will be assumed to exist, they will be drawn from the middle of the road and considered as the borderline of the road (where a body of water or a ditch is on one side of the road the border will be drawn such that the assumed line of 4 meters length is drawn on the other side of the road) (see Diagram 186), then if in the future the already existing buildings should be replaced or moved, the 4 meters marked by the assumed lines will be respected, in extreme cases at least 2.7 meters must be provided (Diagram 187).

Diagram 185

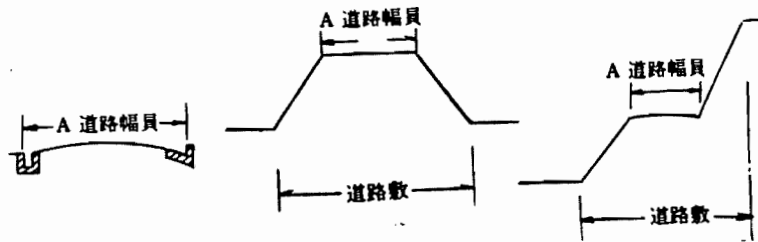

(3) The Relationship between Lots and Roads

In addition to the purposes of general transportation, building lots must be connected to roads without any hindrances to evacuation or fire-fighting. According to the Architectural Standards Law, lots must border on the street for at least 2 meters (road as defined in (2) as more than 4 meters width) (Law 43). (Diagram 189).

However if there is considerable open space around the building in question, and there are no obstacles from a safety point of view, then the 2 meter requirement need not apply (Law 43 part 1).

Diagram 189

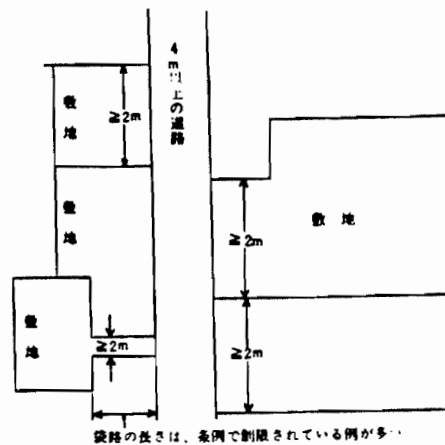

On the other hand it is hard to expect 2 meters exposure to the street to be enough for evacuating people from special structures (schools hospitals, theaters, moviehouses, department stores, hotels, housing projects, factories, parking garages, etc (Law 2 part 2), windowless buildings, large-scale bulidings(extended area of over 1000sqm.))

and so special restrictions may be appended to the regulations concerning these structures. (Law 43 part2)

Also, since no pedestrians are allowed on roads restricted to automobiles, it is not appropriate to consider these roads for the 2 meter requiremnet on lots. (Law 43 part 1)

In this way it is necessary for lots to border on the road for a certain distance, however if that road be a private road, the owner could decide of this own will to close it down or change it. In that event, the closing or changing of a private road, if this should cause a lot bordering on this road to become unacceptable to the law, then it is possible for a SpecialAdministrative Branch to limit or ban the closing or changing of said road. (Law 45)

4. (4) Building Restrictions within Roads

Since roads are there to provide for general transportation, naturally no objects that inhibit traffic will be allowed on the roads. This is covered under the section on Road Supervision in the Road Law, however, the Architectural Standards Law holds that regardless of public or private ownership of the road, no building activity may take place in the road (Law 44 part1).

(In accordance with Law 68 part 1 #4's regulations, in districts of a District Ordering Plan section of a Zone Plan or districts of a Corridor Ordering Plan, "expected roads" authorized by a Special Administrative Branch will be seen as roads by the definition per Law 42 part1 and these restictions on construction on the roads shall apply Law 68-4 part 4).

a. Objects Built on the Road or Protruding into Road Not Allowed

1. Buildings (depending on the defintion this will cover gates, and fences adjoined to the building) Law 2 part 1)

2. Supporting or Reinforcing Walls for Composing Lot

b. Structures Allowed to be Built on, or Protruding into, Roads

1. Underground structures
2. Public toilets, Police boxes and other structures that have benefits for the public but do not hinder traffic flow.
3. Arcades, pedestrian overpasses, and structures which receive permission from a Special Administrative Branch (Order 145).

5. (5) Wall or other Partition Lines

Since it is not allowed to construct buildings over the road border line, if that demarcation exists at least space for the road can be guaranteed. However, what if, for example, that space was used in a residential area to better the surroundings through the creation of a front yard, or if in order to keep the noise of passer-bys down a special walkway was erected in front of a store lot, or in the case of restricting buildings back beyond a certain line, in all these cases a Special Administrative Branch authorizes the Wall Line (law 46).

Authorization for Wall Lines is to be positively executed by a Special Administrative Branch, however, as regards the use of a given lot there are considerable restrictions on the rights related to this use, so when giving these authorizations it is necessary to first hear the interested parties and pass it through some form of deliberative assembly and other procedures that may be called for. (Law 46 part1-3).

In the case of Wall Line authorization:

1. Wall for a building or a column in its place (excluding the portion below surface level)
2. Wall or gate over 2 meter height (excluding the portion below surface level)

are not to be constructed (Law 47).

Diagram 190

Diagram 190

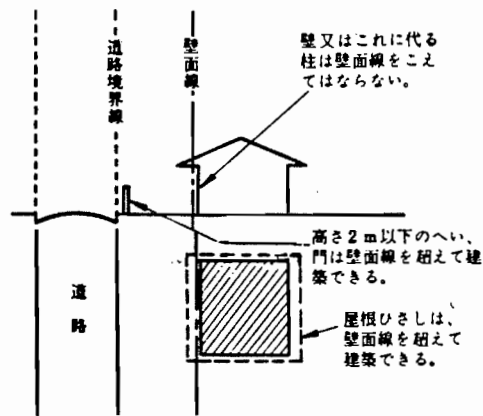

SECTION III Part 3 Land Use (Zoning)

(1) Meaning of a Zoning System

Cities are a collection of buildings for a variety of uses. If these buildings of such different uses were allowed to be constructed without any planning or order then the city would become confused and a problem for everyone, as well as resulting in a much lower efficiency level for urban functions. It is here, following a Land Use Plan that buildings of a similar use can be gathered together in their own district of urban land, and at the same time buildings of a use not compatible to that section may be excluded. This then is the purpose of a Land Use Plan; to provide a rational land use system for urban areas.

The advantages of gathering together similar use structures under a Land Use Plan are:

1. A peaceful environment can be maintained through the association of residential homes. (environmental preservation)
2. The collection of stores and offices will make daily life easier for citizens (service improvement).
3. The collection of manufacturing facilities will result in higher production efficiencies, and reduce the harmful influence of industrial pollution (advancement of efficiency). By keeping out high

return projects (commercial construction) a rise in land prices can be avoided.

(2) Categories of Land Use Districts and Construction Restrictions

a. Land Use District (zone)

The following are the eight categories of Land Use District (Urban Planning Law 8)

1. First Class Restricted Residential Areas
2. Second Class Restricted Residential Areas
3. Residential Areas
4. Neighborhood Commercial Areas
5. Commercial Areas
6. semi-Industrial Areas
7. Industrial Areas
8. Restricted Industrial Areas

The construction of Buildings with uses considered to be undesirable for each of these categories of land use is banned (Law 49). The outline for these conditions follows in Diagram 191 (for details of the law see legal classification chart 2).

Diagram 191

用途地域	建築できない建築物の用途の概要
第1種住居 専用地域	<p>住宅、兼用住宅〔令130-3条〕、共同住宅・寄宿舍・下宿、学校（大学・高専・専修学校・各種学校を除く）、図書館等、神社・寺院・教会等、養老院・託児所等、公衆浴場（個室付浴場業を除く）、診療所、巡査派出所・公衆電話所</p> <p>公益上必要な建築物（小規模の郵便局・地方公共団体支所・福祉施設等、近隣住区内公衆便所〔令130-4条1項〕、小規模の電報電話局・電気事業用変電所等・ガス事業用バルブステーション等・水道事業用ポンプ施設・公共下水道用ポンプ施設・都市高速鉄道停車場等〔令130-4条2項、昭45建告1836号〕）</p> <p>上記の建築物に附属するもの（大規模な車庫、畜舎（>15㎡）、一定の危険物の貯蔵・処理施設（別表第二は項6号・令</p>

以外のすべての建築物

	130-9条)などは、附属建築でも、不可(令130-5条))
第2種住居 専用地域	自動車車庫(>50㎡。都市計画決定のもの。附属車庫(令130-8条)を除く)、倉庫業倉庫、一定の危険物の貯蔵・処理施設(別表第二は項6号、令130-9条)、劇場・映画館・演芸場・観覧場、待合・料理店・キャバレー・舞踏場等、個室付浴場業、二層(令130-5条)を有する、ボーリング場・スケート場・水泳場、まあじゃん屋・ぱちんこ屋・射撃場等、ホテル・旅館、自動車教習所、畜舎(>15㎡)(令130-7条)、3層以上の部分を「第1種住居専禁止用途」に使う建築物(例外は、大学・高専・専修学校等、病院、福祉施設等、校務室・郵便局・警察署・保健所・消防署等、電報・電話局(令130-7-2条、昭52建告1422号))、「第1種住居専禁止用途」に使う部分が1,500㎡を超える大規模建築物(例外は、大学・高専・専修学校等、病院、福祉施設等、校務室・郵便局・警察署・保健所・消防署等、電報・電話局(令130-7-3条、昭52建告1422号))
住居地域	近隣商業地域内で禁止される建築物 工場(原動機使用の作業場>50㎡) 工場:別表第二は三号にかかげるもの(19種:略) 自動車車庫>50㎡[一部除外;令130-8条] 倉庫業を営む倉庫 危険物貯蔵庫〔政令指定:令130-9条〕
近隣商業地 域	商業地域内で禁止される建築物 劇場・映画館・演芸場・観覧場、待合・料理店・キャバレー・舞踏場、個室付浴場業の公衆浴場
商業地域	準工業地域内で禁止される建築物 工場(原動機使用の作業場>150㎡;日刊新聞の印刷所を除く) ただし、自動車修理工場>300㎡ 工場:別表第二は三号にかかげるもの(26種:略) 危険物貯蔵庫(政令指定:令130-9条)
準工業地域	工場:別表第二は一号にかかげるもの(29種:略) 危険物貯蔵庫(政令指定:令130-9条)
工業地域	ホテル・旅館、待合・料理店・キャバレー・舞踏場、個室付浴場業の公衆浴場、劇場・映画館・演芸場・観覧場、学校、病院
工業専用地 域	工業地域内で禁止される建築物 住宅、共同住宅・寄宿舎・下宿、物品販売業店舗・飲食店、図書館・博物館、ボーリング場・スケート場・水泳場、まあじゃん屋・ぱちんこ屋・射撃場
	注1:類似用途を含むものがある。 注2:指定工作物の制限については、第6節⑤を参照のこと。 注3:詳細には、法別表第2を参照のこと。

3. (3) Exceptional Construction Permissions

The above (2) deals with restrictions in principle for each of the land use districts, however a Special Administrative Branch can overrule these restrictions on land use area or district when it recognizes that there will be no threat to the welfare or hindrance to the convenience of the district or area, or when it cannot be helped in order to provide public benefits. When this is the case buildings that would in principle be restricted are allowed as exceptions (Law 48 part 1-8).

In such cases the Special Administrative Branch must request the attendance of interested parties at a hearing and take all views into consideration, furthermore, the concurrence of a deliberative assembly is also required before permission can be granted (Law 48 part 9).

4. (4) Special Use Districts

Authorizations for land use are there to see to it that there is at at least some system of land use in urban areas, but there are many areas in which these regulations are too general to make full use of particular regional characteristics, particular productive characteristics and the finer degrees of purification in certain areas, as well as maintaining an environment conducive to a fuller use of the available land. And so there is a system of special use districts to cover these areas and ensure the more effective utilization of the particular characteristics of regional production and land (Law 49).

The following are the eight categories of Special Land Use Districts (Urban Planning Law 8,9, same Order 3) and are to be established within normal Land Use Districts.

1. Special Industrial District
2. Educational-Cultural District
3. Small Store District

4. Office District
5. Public Welfare District
6. Amusement-Recreation District
7. Tourist District
8. Special Business District

The effectiveness of Special Land Use authorizations can be seen from the following example of the application of a Special Industrial District. In other words, within an Industrial Area or Restricted Industrial Area any kind of industrial manufacturing plant can be built, however heavy industry and precision manufacturing do not necessarily have the same kind of requirements as to land, also depending on the industries involved, the positioning of one plant next to the other could have an undesirable influence on the other, or even create a hazard. In this case it is certainly better to have similar industries grouped together to avoid such problems, and at the same time increase the convenience of the industries concerned. Also there are cities in which the regional industry, be it textiles, brewing, metalworking plants, etc are scattered throughout the city so that when authorizations on land use are made it is necessary to grant individual exceptional permission to each facility. Of course from the point of view of standardization or purification of land use or land use districts this is not a favorable phenomena but, for example when part of the production process of textiles takes place in the home as a cottage industry, and thus one part of a residential home is used for this purpose, which is not uncommon, it is thus possible to give authorizations recognizing that, limited to a particular model, construction of this sort may be allowed in residential districts.

A special feature of this form of authorization is that building restrictions in a Special Land Use District are determined by local

public bodies. However, these Special Land Use Districts come under the authorization of Land Use Areas, but according to regulations, if the Land Use restrictions are appended or relaxed then at least with regard to the Special portion, the ground work of the Land Use restrictions will not apply. Also, although here no distinctions has been made between urban, prefectural, or municipal bodies in the general designation "regional public body", in principle it is appropriate for the municipal-local authorities to codify the contents of the restrictions.

5. (5) The Position of Buildings for Special Uses

1. Wholesale markets

2. Creamatoriums

3. Animal pens, waste disposal facilities, garbage incineration facilities, and other disposal facilities,

are all necessary public facilities without which a city cannot function, but on the other hand which cannot be placed just anywhere. In other words the Urban Plan must be followed in order to determine the most suitable position for this kind of facility, then again in accordance with the plan new construction or additions called for must be built. (Law 51) However, in cases where a Special Administrative Branch recognizes that there are no problems with a proposal that has passed through discussion at a deliberative assembly it may give permission for building.

For new construction, additions or a change in major function of the facility within a certain specified model there are no particular limits on the position of the facility.

6. (6) Other

a. Measures for already existing buildings

The following is an outline of the scope of allowable additions and renovations on buildings that already existed at the time of Land Use authorizations but did not comply with those regulations (Order 137-4).

1. The area or extended area of the building after addition or renovation is within the proscribed building-to-lot proportion and capacity limits (Order 137).

2. The floor space after addition or renovation is less than 1.2 times that of the building at the time the standards were issued.

3. The floor space of workplace or shop is also less than 1.2 times that of the plant at the time the standards were issued.

4. In the case of a machine's output being the cause of original unacceptability, after renovation or addition the rated capacity for that machine's function will be 1.2 times that of the old machine.

b. Measures for a change in use

In the event of a change in the use of a building in a designated Land Use district or Land Use Area, that new use must be one allowed by those Land Use regulations (Law 87 part 2).

However, if that building was already used for a purpose contrary to Land Use regulations before the promulgation of those regulations, then its use may be changed to a similar use at a later date. (Law 87, Order 137-10)

SECTION IV Part 4 Relationship Between Building Height, Surface Area and Lot Surface Area

- 1. (1) Proportion of extended surface area to lot surface area (volume proportion)

The extended surface area of buildings (in the case of two structures on one lot the total surface area of both will be used) divided by the lot surface area, (commonly referred to as the volume capacity proportion) must be within the values proscribed by

Diagram 193. The idea here is to grasp urban density and land use rates through figures on building volume capacity and to order urban use facilities accordingly (Instead of using numbers for extended surface area, the Architectural Standards Law uses a foreign code for measuring volume capacity). (Law 52) If a building's lot faces a planned road or if that road should run through the lot (Law 42 part 1 #4 excepted), then with permission from a Special Administrative Branch that planned road can be counted as road running in front of the lot and figured into the capacity calculations (however that planned road's portion may not be counted in the volume capacity) (Law 52 part3).

Also, restrictions on volume capacity can, in the following cases, be relaxed by a Special Administrative Branch

1. When a considerable portion of the building is taken up by machine or equipment rooms (Law 52 part 4 #1).
2. When there are empty spaces, like parks, public squares or roads surrounding the building (Law 52 part4 #2).

Also, in the event of making additions to or renovating a building that already exceeded volume capacity regulations in a volume capacity district, with the exception of parking garages, will be allowed within specified limits (Order 137-5).

2. (2) Proportion of Building Base Area to Lot Area (Structure/Lot)

The building's base area divided by the lot area yields what is commonly known as the structure/lot proportion. Shrinking this figure simply means providing more lot area around a given building, and contrariwise, increasing the value of this proportion means increasing the density of buildings and shrinking the space between them.

Diagram 196

図表 196

建 べ い 率

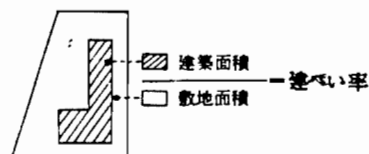

Accordingly, the structure/lot proportion, along with the previously mentioned volume capacity proportion and restrictions on building height are a decisive factor in determining the form of the city.

In accordance with the Architectural Standards Law, the structure/lot proportion is determined in the land Use Area regulations (and in the Urban Plan decisions) (Law 53 part 1), furthermore, even if it should be a fire prevention district, if the buildings in question are made of fire-resistant materials or located on a corner lot, then in order to provide a high level of land utilization restrictions on the structure/lot proportion may be relaxed (Law 53 part 3,4).

3. (3) Building Height in Restricted Residential Areas and Wall Positioning

In order to preserve a favorable environment for low level houses in a restricted residential area, and different from all other areas, an absolute height restriction of 10 meters has been established. Also, all walls and other partitions must be placed at least 1 meter from the boundary line of the property in accordance with authorizations by the Urban Plan (Law 54, 55).

There are no restrictions as to how far back a wall must be if there is no authorization for the district (by the Urban Plan). Also there is an exception clause written into Order 135-5's restrictions concerning the placement of objects on property. The absolute restriction on height may also be relaxed by a Special Administrative Branch when it is clear that no harm will come to the surrounding environment or when it is not possible to otherwise do without the structure in question. (Law 55 part 2 #1.2) Also, if the plan for the layout of the lot has over a specified amount of open space and the Special Administrative Branch recognizes that there is no threat to the low level residential environment, then the height restriction may be relaxed to 12 meters.

(for reference see Diagram 200).

4. (4) Height Restrictions According to Road Width

The objective of these restrictions is to see that by setting the height of buildings on each side of the road according to the width of that road, not only will the road itself receive a proper amount of sunlight and pass along enough wind, but the buildings themselves will receive enough sunlight and that the space between buildings will be sufficient for ventilation purposes. A line at a specified angle from the far border of the road in front of the building, commonly known as the incline restriction, contains the building in order to provide this sunlight and space (Law 56 part 1 # 1, Order 131-2 to 135-2).

Diagram 201 図表 201

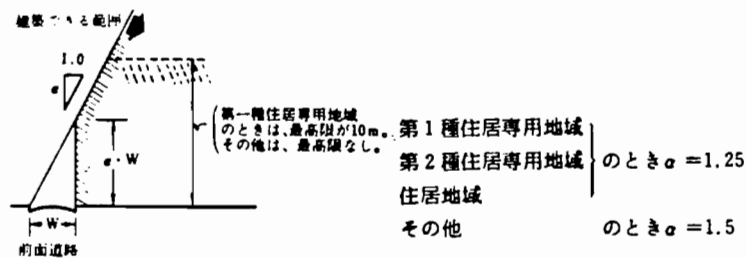

The front-facing road is a road that the building's lot faces, but the following are also to be considered front-facing roads (Order 131-2).

1. Zones that have become urban districts

Land arranged under execution of a Land Management Plan and other districts similarly made into urban districts can, with the authorization of a Special Administrative Branch can be excluded from the restriction system based on individual lots and dealt with in a system that treats districts as the unit, in other words the district itself is seen as one big lot, and thus only the roads at the border of the district would be seen as front-facing roads. Accordingly, all roads within the district would be exempt from the incline line

restriction.

2. Plan Roads

The Architectural Standards Law does not recognize a Plan Road as a road. However, on the one hand such roads may have easily removed structures of wood or steel built upon them up to 2 stories tall and without basements (with the authorization of urban or prefectural governor) but reinforced concrete structures must be set back past the road borders assigned under the Urban Plan (Urban Plan Law 53,54). Accordingly, in such cases if a Special Administrative Branch recognizes that there is no particular impediment the Plan Road may be considered a front-facing road and the restriction on height may be relaxed.

[1] When lot touches on 2 or more roads (Order 132)

When a building faces two or more roads then according to items 1 through 3 of Diagram 203, depending on which portion of the building faces which road, the front-facing road may be determined (postulated) (Order 132).

[2] When there is a park, public square, or water on the other side of the front-facing road (order 134)

The borderline on the other side of the park or square is to be considered the borderline adjacent to the front-facing road in the calculations for height restriction. It goes without saying that this will constitute a considerable relaxing of the restriction.

Diagram 205

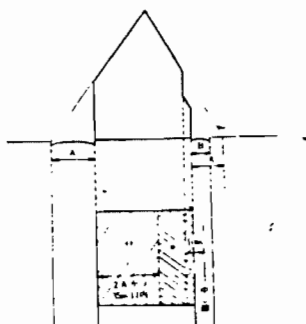

[3] When there is a Wall Line authorized for the other side of the front-facing road (Order 135)

This item will be dealt with the way as [2], it results in a relaxation of the height restriction.

[4] When there is a difference in the height of the front-facing road and lot (Order 135-2)

For the building height restrictions mentioned in this section, the height will be measured from the middle of the surface of the front-facing road (Order 2 part 1 # 5).

Here, when the difference in height between the building's lot and front-facing road is over 1 meter the following measures may be taken.

1. View the front-facing road as being in a position only one half of the height difference minus 1 meter or

2. If because of the particular shape of the land it is not possible to apply 1. then it must be dealt with by separate regulations of a Special Administrative Branch.

Diagram 206 & 207

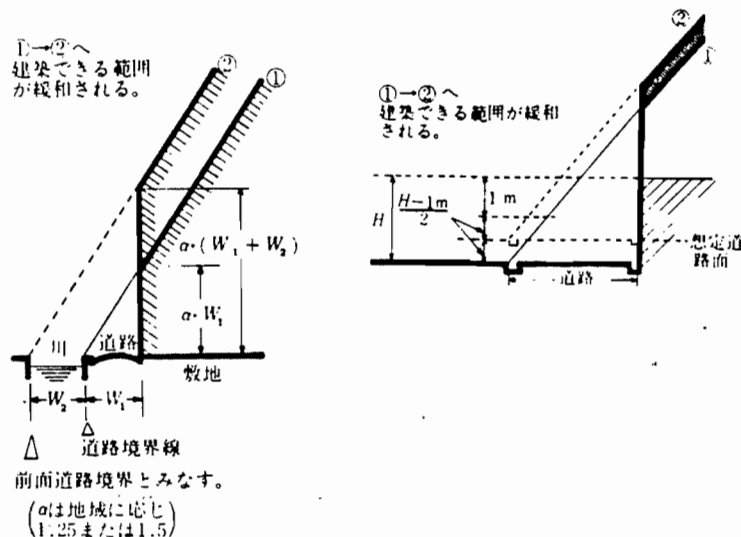

5. (5) Height Restrictions According to the Neighboring Lot Borderline

In the same way that the width of the front-facing road was used to determine a building height restricting incline line limit for the preservation of sunlight and air passage on the road, so the neighboring lot borderline will be used with an incline line to restrict the height of a given building (Law 56 part 1 # 2).

In accordance with Order 131-2 part 2, when a Plan Road is considered to be the front-facing road it is not necessary to think of an inclination line restriction from the neighboring lot borderline within that road (Order 135-3 part 1 # 3).

[1] Relaxation of neighboring lot borderline incline line restrictions if the lot borders on a park, public square, or water (Order 135-3 part 1 # 1).

[2] Relaxation of the neighboring lot borderline incline line restrictions when the ground level of the neighboring lot is lower than the first lot (Order 135-3 part 1 # 2).

Diagrams for Chapter 3

Diagram 183

1. Framework for Urban Plan
2. High rank plan, development, consolidation plan, etc.
3. Plan for use of national land (national-urban and prefectural-local)
4. Urban and prefectural (Basic Plan for Land Use)
5. Composite Development Plan for National Lands (national-local. urban prefectural. special areas)
6. Consolidation plan for capital area and regional areas, other
7. Authorization for district and area Urban Plans
8. Population, industry, culture and the state of other natural social conditions plus their future trends
9. Urban Plan (urban plan as defined by law)
10. Urbanization of districts and areas and adjustment of urbanization of districts and areas
11. Planned urbanization, regulations concerning development activity system of permission for development
12. Area or district
13. Use area or district, special use area or district, high level district, high utilization area, specially designated urban districts, fire prevention, semi-fire prevention areas, scenic areas and districts, beautiful sights area and district, parking or garage district, harbor supervision district, historical preservation districts, green area preservation districts, transportation business districts, productive green area districts, Preservation area for traditional structures
14. Stimulative areas and districts
15. Urban redevelopment stimulation districts and areas, land zoning stimulation districts and areas, urban residential district adjustment

stimulation districts and areas

16. Urban facilities

17. Transportation facilities (roads, high speed urban railroads, parking lots, automobile terminals, etc.)

18. Public open spaces (parks, green areas, public squares, cemeteries)

19. Supply and disposal facilities (water, electricity, gas, sewers, waste treatment plants, garbage incineration plants)

20. Waterways (rivers, canals)

21. Educational-cultural facilities (schools, libraries, research institutes)

22. Medical , social welfare facilities (hospitals, sanitoriums)

23. Markets, livestock pens and creamatoriums

24. District residential facilities

25. District Official department facilities

26. Transportation business

27. Public electrical and communication facilities, windbreaks, fire-prevention, flood prevention, sand prevention and tide prevention facilities.

28. Urban land development projects

29. Land zoning adjustment projects

30. New residential urban land development projects

31. Industrial districts structuring projects

32. Urban land redevelopment projects

33. New town base adjustment projects

34. Residential adjustment projects

35. Projected districts and areas for urban development projects

36. New residential urban land development projects, structuring of industrial districts, consolidation of foundation for new towns, residential facilities for on district, facilities for district official

and proposed districts for transportation industries

37. District planning

38. district plan, plan for regulation of roads

Diagram 184

1. Fundamental laws

2. law

3. purpose, main contents

4. supplemental information

5. Urban Planning Law

6. see (2)

7. National Land Utilization Plan Law

8. National land is a limited resource, it forms the base for living and producing activities and should be used for public benefit, should receive protection for maintaining the natural environment, and the natural, social, economic, and cultural conditions of a given district taken into consideration; the ideal of this law is to promote an even development of these lands to maintain the living environment and cultural health of the community.

9. The carrying out of the national land utilization plan (national-urban and prefectural-local) policies, basic plan for utilization of urban prefectural land (cities, agriculture, forests, nature parks, and natural preservation districts's policies, measures for urban utilization regulations (regulations for district or area authorization)

③ 都市計画に関連する他の法令

図表 184

A. ① 基本的な法律

法 (2)	目的、主な内容	備考 (4)
① 都市計画法	(参照) ⑤	
② 国土利用計画法	⑧ 国土は限られた資源であり、生活・生産等の活動基盤であるという基本認識に基づき、公共福祉優先、自然環境保全、自然・社会・経済・文化の地域的条件に配慮しつつ、健康で文化的な生活環境の確保と国土の均衡ある発展を図ることを理念とする法律	⑨ 国土利用計画（全国・都道府県・市町村）計画の策定、都道府県土地利用基本計画（都市・農業・森林・自然公園・自然保全の各地域指定）の策定、土地利用規制等の措置、土地取引規制措置（規制区域指定）などを行う。
③ 国土総合開発法	⑩ 国土の総合的利用・開発・保全・産業立地適正化を図る法律	⑪ 国土総合開発計画（全国・地方・都道府県・特定地域）の策定・促進を行う。
④ 首都圏整備法	⑬ 首都圏の整備に関する総合的な計画を策定し、秩序ある発展を図るための法律	⑫ 近郊整備地帯、都市開発区域を指定できる。 既成市街地内では、一定規模以上の工場、学校の新増設は禁止される。〔首都圏の既成市街地における工業等の制限に関する法律〕 都市開発区域内で都市計画決定による工業用地造成事業を施行できる。
⑤ 中京圏開発整備法	⑭ 首都圏整備法にはほぼ同じ	
⑥ 近畿圏開発整備法	⑮ 同上	

20⁷ その他
北海道開発法、東北開発促進法、北陸地方開発促進法、中国地方開発促進法、九州地方開発促進法、新産業都市建設促進法、自然環境保全法、工業用地開発促進法など

ろ 都市施設に関する法律

1182p

① 法	② 目的、主な内容	③ 備 考
④ 道路法	⑤ 道路網を整備するため、路線の指定、認定、管理、構造、保全等に関する事項を定めた法律	⑥ 道路の種類—高速自動車国道、一般国道、都道府県道、市町村道 道路の構造は道路構造令による。 道路の占用—電柱、電線、歩廊、地下街等を設けて使用する場合は、道路管理者の許可を要する。
⑦ 駐車場法	⑧ 都市における自動車の駐車施設を整備し、道路交通の円滑化、都市の機能の増進を図るための法律	⑨ 商業地域内に、都市計画の施設として、駐車場整備地区を指定できる。 ⑩ 路上駐車場、路外駐車場の設置、整備 ⑪ 条例により、延べ面積3,000㎡以上又は特定用途の建築物には一定規模(台数)の駐車施設を義務づけられる。 ⑫ 駐車場の構造、設備の基準(同法施行令)
⑬ 都市公園法	⑭ 都市計画法による公園又は緑地(都市公園)の設置、管理に関する法律	⑮ 都市公園内に設けられる建築物の建築面積は公園の敷地面積の2/100以下。
⑯ 下水道法	⑰ 主として市街地における下水を排除又は処理するため、公共下水道及び都市下水路の設置、管理の基準を定めた法律	⑱ 公共下水道とは、地方公共団体が設置する下水道で、下水を排除すべき区域の面積が20ヘクタール以上のもの又は終末処理場を有し、排水施設の相当部分が暗渠であるもの。
⑲ 水道法	⑳ 水道の布設、管理を適正、合理的ならしめるため、水質基準、施設基準、水道事業の認可基準等を定めた法律	
21 ⑳ その他		都市緑地保全法、港域法、河川法、無印給事業法、自動車ターミナル法、船隻法、地方官選任法、物産法、高速自動車国道法、日本道路公団法、地方道路法

(は) 都市の開発又は再開発に関する法律

法 律	目的、主 要 内 容	備 考
<p>① 新都市基盤 4 整備法</p>	<p>5 大都市周辺に新都市を建設するための基盤整備に必要な手法を定めた法律</p>	<p>6 〇道路、河川その他の根幹公共施設、一団地の住宅施設、福祉利便施設などを一体的に整備することを目標としている。 7 〇施行者は、地方公共団体・日本住宅公団・宅地開発公団など。 8 〇必要な土地整理、土地収用などについて定めている。</p>
<p>9 ② 土地区画整理法</p>	<p>10 健全な市街地を造成するため、土地区画整理事業を施行する場合の施行者、施行方法、費用の負担等を定めた法律</p>	<p>11 〇施行者は、個人・組合・市町村・日本住宅公団・宅地開発公社・地域振興整備公団など。 12 〇施行についての認可公告、組合設立の認可公告、事業計画の認可公告等があった日から、換地処分の公告がある日までは建築物その他の建築行為が制限される。 13 〇換地計画で、事業の施行の費用に充てるため一定の土地を保留地として定めることができる。 14 〇事業計画の内容及び技術的基準は、土地区画整理法施行規則に定められている。</p>
<p>15 ③ 都市再開発法</p>	<p>16 土地の高度利用と都市機能の更新を図るための市街地再開発事業の施行者、事業計画、権利変換計画等を定めた法律</p>	<p>17 〇旧市街地改造法と旧防災建築街区造成法とを統合整備した法律で、高度利用地区内において、建築物の適正高度利用と公共施設の整備を合せて行う再開発事業について規定している。 18 〇施行者は、個人・組合・地方公共団体・日本住宅公団・地域振興整備公団など。</p>
<p>19 ④ 新住宅市街</p>	<p>20 人口集中の著しい市街地の周辺</p>	<p>21 〇施行者は、地方公共団体・日本</p>

CONTINUES FROM PREVIOUS PAGE

<p>19 20 地開発法</p>	<p>20 21 に、新住宅市街地開発事業を施行する場合の調査、土地の買取請求、貸出、事業計画等を定めた法律</p>	<p>第3章 健全な街づくりのための基準 239 21 22 住宅公団・地方住宅供給公社・宅地開発公社・地域振興整備公団・一定の法人など。</p>
<p>26 住宅地区改良法</p>	<p>27 不良住宅が密集する地区を改良し、健全で文化的な住宅（改良住宅）を集中的に建設するため、住宅地区改良事業等を定めた法律</p>	<p>事業の施行区域の主な条件 25 イ）主要な公共施設が都市計画決定されていること ロ）1以上の住区（約1万人）を形成できること ハ）区域の大部分が住居専用地区内</p>
<p>28 大都市地域における住宅地等の供給の促進に関する特別措置法</p>	<p>29 首都圏・近畿圏・中部圏内の大都市圏域において、大量の住宅地供給と良好な住宅街区整備を促進することを目的とする法律</p>	<p>30 国・関係地方公共団体による宅地開発協議会を設ける。 31 都市計画に、上地区画整理促進区域・住宅街区整備促進区域を定める。 32 特定上地区画整理事業・住宅街区整備事業を推進する。 33 施行者は、個人・組合・地方公共団体・日本住宅公団・地方住宅供給公社など。</p>
<p>34 その他</p>	<p>公営住宅法、住宅金融公庫法、日本住宅公団法、宅地開発公団法、地域振興整備公団法、住宅供給公社法など。</p>	

10. Composite Development for National Lands Law
11. Law providing for the general use, development, protection, and seeing to the proper role for industry for national lands
12. Composite Development Plan for National Lands (national, local, urban and prefectural, and special area) and the stimulation and execution of policies thereof
13. Capital Consolidation Law
14. Law providing policies for the general plan for consolidation of the nation's capital and for orderly development
15. Consolidation of suburban belt and authorization of city development districts and areas. Within already established urban areas enlargement of factories and schools above a certain specified scale is banned. (Law concerning industry and other structures on already established urban lands in the capital and restrictions thereupon). It is possible to execute projects for structuring industrial areas according to urban plans in urban development districts and areas.
16. Midland Sphere Consolidation Law
17. Approximately the same as the Capital Consolidation Law
18. Osaka-Kyoto Sphere Consolidation Law
19. Same as above
20. Other, Hokkaido Development Law, North-east Development Stimulation Law, North Regions Development Stimulation Law, Midland Region Development Stimulation Law, Kyushu Region Development Stimulation Law, New Industrial Town Construction Stimulation Law, Natural Environment Preservation Law, Industrial Relocation Stimulation Law, etc.

B Laws Concerning Urban Facilities

1. Law
2. Purpose main contents
3. Supplemental information

4. Road Laws

5. This law determines matters pertaining to route authorization, recognition, structure, management and safety for the consolidation of a road network.

6. The categories of road - highway, interstate roads, urban and prefectural roads, and local roads-will be determined by the Road Construction Order. Road supervisors' permission is required for providing or using light or telephone poles, waterpipes, walkways, and underground arcades.

7. Parking Law

8. A law intended to increase the efficiency of urban roads, make traffic smoother, and to consolidate parking facilities for cars in cities.

9. This law can authorize consolidated parking districts as a facility of the Urban Plan within commercial areas.

10. the establishment and consolidation of off and on the road parking facilities.

11. Depending upon the clause, buildings with an extended floor area of over 3,000 sqm. or specially designated buildings will require parking facilities for a specified number of cars.

12. Standards for structure and equipment of a garage (same law, execution order).

13. Urban Park Law

14. Law concerning the establishment and supervision of parks and green areas(urban parks) according to the Urban Planning Law.

15. The surface area of structures built within the park must be less than 2/100 of the park lot area.

16. Sewage Law

17. Law that determines standards for the supervision and establishment of urban and public sewage routes for the removal and disposal of urban sewage.

18. Public sewage is sewage established by a regional public body, and sewage should be removed from areas or districts of over 20 hectares or else they should have a disposal plant, and a considerable portion of the drainage facilities are culverts.

19. Waterworks Law

20. Law which determines standards for the approval of waterwork projects standards for equipment, and standards for water quality so that rational and proper supervision of the dispensing of water can be obtained.

21. Other Urban Green Area Preservation Law, Harbor Law, River Law, Heat Supply Project Law, Automobile Terminal Law, Airport Law, Regional Railways Law, Tramway Law, National Highway Law, Japan Road Group Law, Regional Road Public Association Law

C. Laws Concerning Urban Development or Redevelopment

1. Law

2. Purpose main contents

3. supplemental information

4. New Cities Base Consolidation Law

5. Law determines procedures for consolidation of the bases for the construction of new cities around major urban centers

6. Roads, rivers and other trunk public facilities, residential facilities for a group, and social welfare facilities are all to be consolidated into one base, this is the goal of this law.

7. The executors are either regional public bodies, the Japan Residential Public Group, Residential Area Development Group, etc.

8. Determines necessary land organization and appropriation.

9. Land Zoning Organization Law

10. Law determines the financial burden and methods for the executor of zoning organization projects for the structuring of a healthier city.

11. The executor is either an individual, union, local town, the Japan Residential Public Group, Residential Development Public Group, Area Growth Consolidation Public Group, or others

12. Building restrictions take effect from the day the authorization is announced, the union is established, the project plan is authorized, until the day of moving in is announced.

13. According to the Substitute Land Plan, it is possible to preserve a specified amount of land to see to it that the financial expenses for project execution are sufficient.

14. The standards for contents and techniques for the project plan will be determined by the regulations of the Land Zoning Consolidation Law.

15. Urban Redevelopment Law

16. Law that determines rights substitution plan, project plan, so that the executor of the Urban Redevelopment Plan may work towards the renewal of urban functions and a higher utilization of land.

17. This is a law that consolidates the old Urban Renovation Law and the old Disaster Prevention Construction Composition Law and it regulates Redevelopment Projects in which both the consolidation of public facilities and proper high-level utilization of land in high-level utilization districts are combined into one set of regulations.

18. The executors are either individuals, unions, regional public bodies the Japan Residential Public Group, or Area Growth Consolidation Public Groups

19. New Residential Towns Development Law

20. Around cities with marked population concentrations the New Residential Towns Projects will be executed after research (survey), appropriation request, appropriation, in accordance with the project plan instituted by this law.

21. The executors may be individual, regional public bodies, the Japan Residential Public Group, the Regional Residential Dwelling Supply Public Association, Residential Development Public Group, Area Growth Consolidation Public Group, or other incorporated bodies specified by these regulations.

22. 23, 24, were skipped as this diagram continues directly from the previous page.

25. Main conditions for project execution districts

- a. major urban facilities are designated under the Urban Plan
- b. it be composed of more than one residential district (10,000 persons or over)
- c. the major part of the district or area be within a restricted residential district.

26. Residential District Renovation Law

27. this is a Law that provides for districts in which poor housing is concentrated, so that they may be renovated and turned into healthy and culturally acceptable areas through residential areas renovation projects.

28. Special Measure Law for Stimulating the supply of Housing in urban districts and areas

29. This law has as its goal the stimulation of the consolidation of good housing districts and increasing the volume of the housing supply for large urban districts in the Tokyo sphere, the Kyoto-Osaka sphere, and the Midlands sphere.

30. The establishment of a residential development assembly either on a national scale, or by concerned regional public bodies.

31. It determines residential town consolidation stimulation districts and land zoning consolidation stimulation districts according to the Urban Plan.

32. It encourages specially designated zoning consolidation projects and residential district consolidation projects.

33. The executors may be either individuals, unions, regional public bodies, the Japan Residential Public Group, Regional Residential Supply Public Association.

34. Other Public Management Residential Law, Residential Credit Finance Public Corporation Law, the Japan Residential Public Corporation Law, the Area Growth Consolidation Public Corporation Law, the Residential Supply Public Association Law.

Diagram 185

図表 185

1. A road width
2. A road width
3. A road width
4. road lot
5. road lot

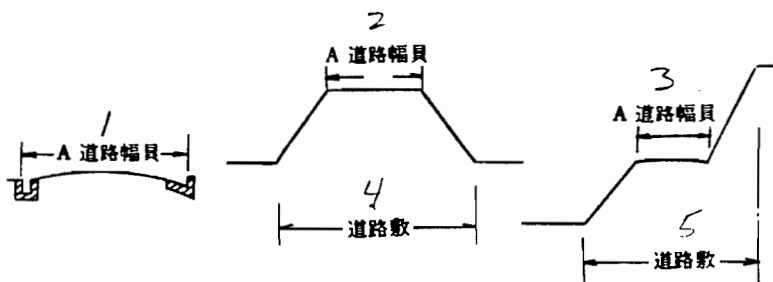

Diagram 186

図表 186

1. Center line of road
2. Borderline of road
3. Borderline of road
4. Center line of road
5. Borderline of road
6. Borderline of road

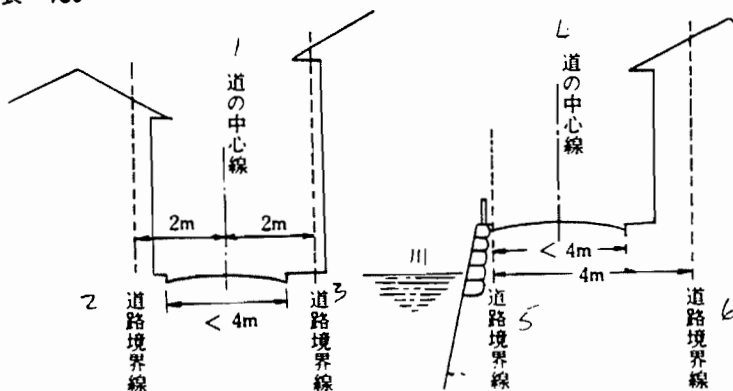

Diagram 187

1. Center line of road
2. Already existing structure
3. Structure built after authorization
4. Road authorized by Law 42 part 2

図表 187

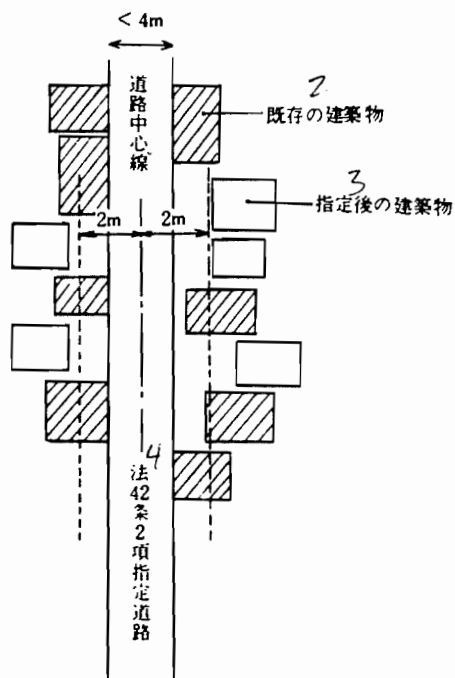

Diagram 188 Standards for Structure of Private Roads (Order 144-4)

1. Width, length and other conditions
2. In the case where both edges apply under Law 42
3. width greater than
4. Whichever of the following 1-5. can be applied
5. road
6. Case of width greater than 4 meters but less than 6 meters
7. When there are less than 35 meters
8. Where there are less than 6 meters, a blind road is not allowed
9. Case of width greater than 4 meters but less than 6 meters
10. road
11. Public square, park, room for cars to turn around, etc.
12. Case of
13. Case of a blind road
14. road
15. Case of width greater than 4 meters but less than 6 meters
16. Where there are less than 35 meters
17. " " " " "
18. " " " " "
19. Room for turning a car around as specified in Ministry Bulletin #1837
20. road
21. private road
22. Case of width greater than 6 meters
- 23 Left to individual
24. Cases 1-4 can be applied where the Special Administrative Branch recognizes that there are no obstacles to emergency evacuation or traffic.
25. Finishing of intersections, connections and curves

図表 188 私道の構造基準 (令111-4条)

<p>⑥ 両端が法定4条道路に通ずる場合</p>	<p>幅員 ≥ 4 m</p>
<p>① ① 幅員・延長などの条件</p>	<p>② 次の1~5のどれかに該当すること</p>
<p>③ 袋路状の場合</p>	<p>(1) 幅員 ≥ 4 m の場合</p> <p>(2) 幅員 ≥ 4 m の場合</p> <p>(3) 幅員 ≥ 4 m の場合</p> <p>(4) 幅員 ≥ 4 m の場合</p> <p>(5) 幅員 ≥ 4 m の場合</p> <p>11 広場・公園・自動車回車場などに通じていること。</p> <p>12 幅員 ≥ 4 m の場合</p> <p>13 幅員 ≥ 4 m の場合</p> <p>14 幅員 ≥ 4 m の場合</p> <p>15 幅員 ≥ 4 m の場合</p> <p>16 幅員 ≥ 4 m の場合</p> <p>17 幅員 ≥ 4 m の場合</p> <p>18 幅員 ≥ 4 m の場合</p> <p>19 幅員 ≥ 4 m の場合</p> <p>20 幅員 ≥ 4 m の場合</p> <p>21 幅員 ≥ 4 m の場合</p> <p>22 幅員 ≥ 4 m の場合</p> <p>23 任意</p> <p>(1)~(4)に準ずる場合で、特定行政庁が避難・通行上、支障なしと認定した場合。</p>
<p>④ 25 交叉部、接続部、屈曲部のすみ切り</p>	<p>(1) すみ切り (2等辺3角形)</p> <p>(2) すみ切り (2等辺3角形)</p> <p>(3) すみ切り (2等辺3角形)</p> <p>26 すみ切り (2等辺3角形)</p> <p>27 すみ切り (2等辺3角形)</p> <p>28 120°</p> <p>29 すみ切り (1)に同じ</p>
<p>⑤ 30 表面の仕上</p>	<p>31 砂利敷、その他ぬかるみとならない構造とすること。</p>
<p>⑥ 32 縦断勾配</p>	<p>(1) $\leq 12\%$</p> <p>33 (2) 段を設けない。</p> <p>100 ≤ 12</p>
<p>⑦ 34 排水施設</p>	<p>35 私道及び周辺敷地の排水に必要な、側溝などを設けること。</p>

26. Finishing (two sided, three conered shape)
27. " " " "
28. Finishing not required for an angle of over 120 degrees
29. Finishing (same as 26)
30. Surface finishing
31. Gravel, or some other surface that will not become muddy
32. Ramp inclination
33. No steps may be constructed
34. Drainage facilities
35. rainage ditches must be dug for the private road and the area around it.

Diagaram 189

1. Lot
2. Road 4 meters or wider
3. Lot
4. "
5. There are many examples of regulations in which the length of a blind road may be restricted.
6. Lot

Diagaram 190

- 1.Borderline for road
2. Wall line
3. The wall, or pillars in its place, may not exceed the height of the wall line.
4. road
5. A gate or fence of over the wall line height may be constructed as long as it is less than 2 meters high.
6. The eaves of a building may extend over the wall line.

Diagram 191 Outline of Building Restrictions within a Land Use District (Law 48 separate diagram 2

図表 189

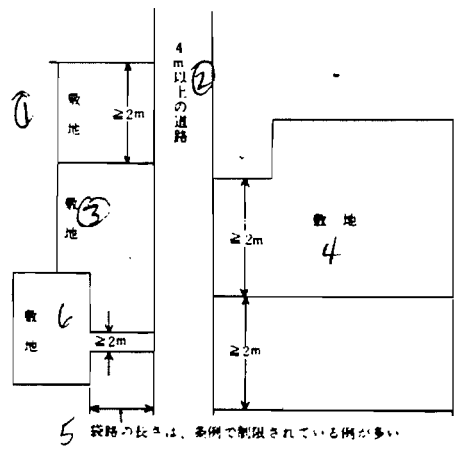

図表 190

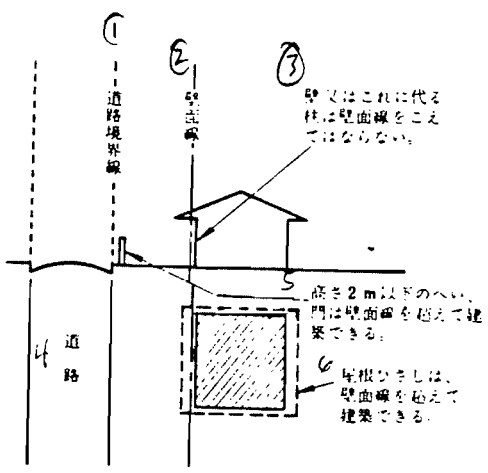

Diagram 191 Outline of Building Restrictions Within a Land Use District (Law 48 appended diagram # 2)

1. Zone
2. Outline of the Uses of Buildings That Cannot be Built
3. First class restricted residential areas
4. Homes, buildings also used as homes (Order 130-3), apartments, boarding houses, rented rooms, schools (universities, vocational high schools, special course schools excepted), diagnostic centers, , libraries, temples, churches, old persons homes, day-care centers, public baths (with the exception of individual booth baths), police boxes, public telephone booths, buildings required for public benefit, (small scale post offices, regional public bodies offices, public welfare facilities, public toilets near residential areas (Order 130-4 part 1), small scale telegraph, telephone offices, transformers for electric projects, valve stations for gas projects, pump facilities for waterworks, pump facilities for public sewage systems, lots for urban high speed trains, (Order 130-4 part 2, Ministry Bulletin # 1836, 1970) The additional construction of even facilities appended to the above structures (large scale garages, animal pens, storage for specified dangerous materials and their disposal facilities (see separate diagram # 2 section 3 part 6, Order 130-9) will not be permitted. (Order 130-5)
5. All other structures
6. Second class restricted residential area
7. Automobile garages (those greater than 50 sqm. , designated by Urban Plan, and attached garages (Order 130-8) are excepted), warehouses and industrial warehouses, Storage facilities for dangerous materials and facilities for their disposal (see separate diagram # 2 section 3 part 6, Order 130-9), theaters, tourist spots, movie houses, coffee shops and restaurants, cabarets and dancehalls, individual booth bathhouses,

図表 191

用途地域	2 建築できない建築物の用途の概要
3 第1種住居 専用地域	<p>4 住宅・兼用住宅〔令130-3条〕、共同住宅・寄宿舎・下宿、学校（大学・高専・専修学校・各種学校を除く）、図書館等、神社・寺院・教会等、養老院・託児所等、公衆浴場（個室付浴場業を除く）、診療所、巡査派出所・公衆電話所 公益上必要な建築物（小規模の郵便局・地方公共団体支所・福祉施設等、近隣住区内公衆便所〔令130-4条1項〕、小規模の電報電話局・電気事業用変電所等・ガス事業用バルブステーション等・水道事業用ポンプ施設・公共下水道用ポンプ施設・都市高速道路停車場等〔令130-4条2項、昭45建告1836号〕） 上記の建築物に附属するもの（大規模な車庫、畜舎（>15㎡）、一定の危険物の貯蔵・処理施設（別表第1項6号・令130-9条）などは、附属建築でも、不可〔令130-5条〕）</p> <p>5 以外のすべての建築物</p>
6 第2種住居 専用地域	<p>7 自動車庫（>50㎡、都市計画決定のもの。附属車庫〔令130-8条〕を除く）、倉庫業倉庫、一定の危険物の貯蔵・処理施設（別表第2項6号、令130-9条）劇場・映画館・演芸場・観覧場、待合・料理店・キャバレー・舞踏場等、個室付浴場業、工場〔令130-6条のものを除く〕、ボウリング場・スケート場・水泳場、まあじゃん屋・ぼらんこ屋・射的場等、ホテル・旅館、自動車教習所、畜舎（>15㎡）〔令130-7条〕、3階以上の部分を「第1種住居禁止用途」に使う建築物（例外は、大学・高専・専修学校等、病院、福祉施設等、税務署・郵便局・警察署・保健所・消防署等、電報・電話局〔令130-7-2条、昭52建告1422号〕） 「第1種住居禁止用途」に使う部分が1,500㎡を超える大規模建築物（例外は、大学・高専・専修学校等、病院、福祉施設等、税務署・郵便局・警察署・保健所・消防署等、電報・電話局〔令130-7-3条、昭52建告1422号〕）</p>
8 住居地域	<p>9 近隣商業地域内で禁止される建築物 工場（原動機使用の作業場>50㎡） 工場：別表第三項三号にかかげるもの（19種：略） 自動車庫>50㎡（一部除外〔令130-8条〕） 倉庫業を営む倉庫 危険物貯蔵庫（政令指定：令130-9条）</p>
10 近隣商業地 域	<p>11 商業地域内で禁止される建築物 劇場・映画館・演芸場・観覧場、待合・料理店・キャバレー・舞踏場、個室付浴場業の公衆浴場</p>
12 商業地域	<p>13 準工業地域内で禁止される建築物 工場（原動機使用の作業場>150㎡；日刊新聞の印刷所を除く） ただし、自動車修理工場>300㎡ 工場：別表第三項三号にかかげるもの（26種：略） 危険物貯蔵庫（政令指定：令130-9条）</p>
14 準工業地域	<p>15 工場：別表第三項一号にかかげるもの（29種：略） 危険物貯蔵庫（政令指定：令130-9条）</p>
16 工業地域	<p>17 ホテル・旅館、待合・料理店・キャバレー・舞踏場、個室付浴場業の公衆浴場、劇場・映画館・演芸場・観覧場、学校、病院</p>
18 工業専用地 域	<p>19 工業地域内で禁止される建築物 住宅、共同住宅・寄宿舎・下宿、物品販売業店舗・飲食店、図書館・博物館、ボウリング場・スケート場・水泳場、まあじゃん屋・ぼらんこ屋・射的場</p>

20 注1：類似用途を含むものがある。
 21 注2：指定工作物の施設については、第6節③を参照のこと。
 22 注3：詳細には、別表第2を参照のこと。

factories (Or r 130-6 items excepted), bowling alleys, skating rinks, swimming pools, mah joong parlors, amusement centers, target ranges, hotels, inns, driving schools, animal pens (15 sqm. and up) (Order 130-7) the portion over 3 stories of a building used for " a purpose banned in the restrictions of a first class restricted residential area"(exceptions to this are universities, high schools (vocational and special course) hospitals, public welfare facilities, tax o-fices, post offices, police headquarters, health centers, fire stattions, telegraph and telephone offices, (Order 130-7-3, Ministry Bulletin 1422, 1977)

8. Residential areas

9. Buildings banned in neighborhood commercial districts, factories (workshops using drive mechanisms with a floorspace of over 50 sqm.), factories: those covered under separate diagram # 2 section 3 part 3 (approx. 19 categories), Automobile garages over 50 sqm. (one section excepted; Order 130-8), warehouses managed by the warehouse industry, storage facilities for dangerous materials (government authorization: Order 130-9)

10. Neighborhood commercial areas

11. Buildings banned within commercial districts, theaters, movie houses, tourist spots, coffee shops and restaurants, cabarets and dance halls, public booths with individual booths attached

12. Commercial areas

13. Buildings banned within semi-industrial areas, factories (those with workshops using drive mechanisms over 150 sqm. ; daily newspaper printing presses excluded, however in the case of an auto repair shop a workflow of over 300 sqm. , factories : those covered under the separate diagram # 2 section 3 part 3 (approx. 26 categories), storage facilities for dangerous materials (government order authorization:

Order 130-9)

14. semi-Industrial areas

15. factories : those covered under the separate diagram # 2 section 6 part 1 (approx. 29 categories), storage facilities for dangerous materials (government order authorization: Order 130-9)

16. Industrial areas

17. hotels, inns, coffee shops and restaurants, cabarets and dance halls, public baths with individual booths attached, theaters, movie houses, tourist spots, schools, hospitals

18. Restricted industrial areas

19. Buildings restricted within industrial areas, homes, apartments, boarding houses and rented rooms, retail item stores, diners, libraries, museums, bowling alleys, skating rinks, pools, mah jong parlors, target ranges, and amusement centers.

20. note 1. including those structures of similar use

21. note 2. see part 6 (5) concerning restrictions on the authorization of building materials

22. note 3. for details refer to the Law separate diagram # 2

Diagram 192 Relationship between the Use of a Building and Its Land Use District (zone)

1. Note: In this diagram O indicates an approved structure, and X indicates a structure that is excluded in principle. However, even within this X classification there are attached and small scale structures that are allowed so it is best to refer to the separate headings for detailed checks.)

2. First class restricted residential
3. Second class restricted residential
4. Residential
5. Neighborhood commercial

建築物の用途と用途地域の関係

① 注：この表で、○は許容されるもの、×は原則的に禁止されるものを示す。ただし、×のうちでも、小規模であること、附属のものであることなどによって、許容されるものもあるので、詳細には、関係条文でチェックのこと。

	2	3	4	5	6	7	8	9
	住	住	住	商	商	工	工	工
	種	種	種	業	業	業	業	業
	住	住	住	業	業	業	業	業
	専	専	居	業	業	業	業	業
10 住宅・共同住宅・寄宿舎・下宿	○	○	○	○	○	○	○	×
11 一定の兼用住宅（店舗付・事務所付）	○	○	○	○	○	○	○	×
12 学校（大学・高専・各種学校を除く）	○	○	○	○	○	○	×	×
13 大学・高専・各種学校	×	○	○	○	○	○	×	×
14 図書館	○	○	○	○	○	○	○	×
15 神社・寺院・教会	○	○	○	○	○	○	○	○
16 養老院・荘園所・診療所	○	○	○	○	○	○	○	○
17 公衆浴場（個室付浴場業を除く）	○	○	○	○	○	○	○	○
18 個室付浴場	×	×	×	×	○	○	×	×
19 送客係出所・公衆電話所・その他公益上必要な小規模建築物等	○	○	○	○	○	○	○	○
20 ゴーリング場・スケート場・水泳場	×	×	○	○	○	○	○	×
21 まあじゅん屋・ぼらんこ屋・射的場	×	×	○	○	○	○	○	×
22 オテル・旅館	×	×	○	○	○	○	×	×
23 自動車教習所	×	×	○	○	○	○	○	○
24 産舎	×	×	○	○	○	○	○	○
25 自動車車庫≦50㎡	×	○	○	○	○	○	○	○
26 自動車車庫>50㎡	×	×	×	○	○	○	○	○
27 自動車倉庫	×	×	○	○	○	○	○	○
28 劇場・映画館・演芸場・観覧場	×	×	×	×	○	○	×	×
29 待合・料理店・キャバレー・舞踏場	×	×	×	×	○	○	×	×
30 病院	×	○	○	○	○	○	×	×
31 物品販売業店舗・飲食店	×	×	○	○	○	○	○	×
32 事務所	×	×	○	○	○	○	○	○
33 博物館	×	○	○	○	○	○	○	×
34 ①工場 令130-2条の小工場	×	○	○	○	○	○	○	○
35 ②" ①③～5以外の工場	×	×	○	○	○	○	○	○
36 ③" 法別表第4第1号、2号の工場	×	×	×	○	○	○	○	○
37 ④" 法別表第4第1号、2号の工場	×	×	×	×	×	○	○	○
38 ⑤" 法別表第4第1号の工場	×	×	×	×	×	○	○	○

6. Commercial
7. semi-Industrial
8. Industrial
9. Restricted industrial
10. Homes, apartments, boarding houses, rented rooms
11. Specified structures also used for homes (shops, offices)
12. Schools (excluding universities, vocational and special course high schools)
13. Universities, vocational and special course high schools
14. Libraries
15. Temples, monasteries, and churches
16. Old persons' homes, day care centers, diagnostic centers
17. Public baths (excluding those with individual booths attached)
18. Public baths with individual booths attached
19. Police boxes, public telephone booths, other small scale structures needed for public benefit
20. Bowling alleys, skating rinks, swimming pools
21. Mah jong parlors, amusement centers, target ranges
22. Hotels, inns
23. Driving schools
24. Animal pens
25. Automobile garages under 50 sqm.
26. " " over 50 sqm.
27. Warehouse industry warehouses
28. Theaters, movie houses, tourist spots
29. Coffee shops, restaurants, cabarets, dancehalls
30. Hospitals
31. Retail stores and diners

32. Offices
33. Museums
34. (1) factories Order 130-6 small factories
35. (2) " factories other than (1), (3)-(5)
36. (3) " Law separate digram # 2 section 3 part 2, 3 factories
37. (4) " Law separate diagram # 2 section 5 part 2, 3 factories
38. (5) " Law separate diagram # 2 section 6 part 1 factories

Diagram 193 Limits to the Volume Capacity Proportion (Law 52)

1. Category of area
2. Volume capacity proportion (whichever is lower, (1) or (2))
3. (1) Value determined for that district
4. (2) Value dependent of front-facing road (when width is less than 12 m.)
5. First class restricted residential area
6. Whichever figure has been determined by the Urban Plan for that district
7. Width of the widest front-facing road x 4/10
8. Second class restricted residential area
9. Whichever of these figures has been detremined for ~~that~~ district by hte Urban Plan
10. Residential area
11. Whichever of these figures has been determined for ~~that~~ district by the Urban Plan
12. Neighboring commercial areas, semi-industrial areas, industrial areas and restricted industrial areas
13. Same as the above
14. Width of the widest front-facing road x 6/10
15. Note: in an area authorized by a Special Administrative Branch this will be 4/10
16. Commercial areas
17. Whichever of these values has been determined for ~~that~~ district by

図表 193

① 地域の種類	② 容積率 [(1)又は(2)のうち、小さい数値以下]	
	(1) その地域について定められる数値	(2) 前面道路による数値 (幅員<12mの場合)
① ⑤ 第1種住居専用地域	5/10、6/10、8/10、10/10、15/10、20/10のうち、その地域について、都市計画で定められた数値	⑦ [幅員最大の前面道路の幅員(m)] × 4/10
② ⑥ 第2種住居専用地域	10/10、15/10、20/10、30/10のうち、その地域について、都市計画で定められた数値	
③ ⑩ 住居地域	20/10、30/10、40/10のうち、その地域について、都市計画で定められた数値	
④ ⑫ 近隣商業地域 準工業地域 工業地域 工業専用地域	同 ⑬ 上	⑭ [幅員最大の前面道路の幅員(m)] ⑮ × 6/10 (注) (注：特定行政庁の指定区域内では、4/10とする。)
⑤ ⑯ 商業地域	40/10、50/10、60/10、70/10、80/10、90/10、100/10のうち、その地域について、都市計画で定められた数値	
⑥ ⑰ 用途地域の指定のない区域 (都市計画・区域内)	40/10	

⑲備考：建築物の敷地が容積率の異なる2以上の地域にわたる場合は、それぞれの地域の部分ごとに算出した延べ面積の限度の合計が、その敷地全体についての延べ面積の限度となる。この場合、実際に建築物をどの地域の部分に建築するかは任意である〔法53条2項〕。

20 容積率V₁の地域！ 容積率V₂の地域



22 この敷地に建築できる延べ面積F_Aは、

$$F_A = (S_1 \times V_1) + (S_2 \times V_2)$$
 である。
 23 従って、この敷地の容積率の限度Vは、

$$V = \frac{F_A}{S_1 + S_2} = \frac{(S_1 \times V_1) + (S_2 \times V_2)}{S_1 + S_2}$$
 となる。

the Urban Plan

18. Districts or areas with no Land Use authorization (within the areas and districts of the Urban Plan)
19. Supplemental information : In the case where buildings lot sits on the border between two areas of differing volume capacity restriction, the parts of the lot that fall in each district should be calculated with their respective formulas and totalled to give the extended surface area, similarly the limits should be totalled to give the limit for the entire lot. In this case it is up the individual which portion of the lot he wishes to erect his building on. (Law 53part 2).
20. Volume capacity proportion district
21. Surface area
22. The extended surface area of this lot that can be built on is ...
23. Accordingly, the volume capacity proportion for this lot is...

Diagram 194 The Proportion between Extended Surface Area and Lot surface Area (volume capacity proportion)

1. Volume capacity proportion = $\frac{\text{extended surface area T}}{\text{lot surface area S}}$
2. Lot surface area S
3. Floor space area (3 to 5 stories)
4. " " " (1 to 2 stories)
5. Extended surface area

Diagram 195

1. An Example of Volume Capacity Proportion of a Building
2. The proportion of extended surface area to lot surface area is 20/10 (volume capacity proportion of 200%)
3. Case where the entire lot is built upon
4. Case where one-half of the lot is built upon
5. The proportion of extended surface area to lot area is 50/10 (volume

図表 194

延べ面積の敷地面積に対する割合 (容積率)

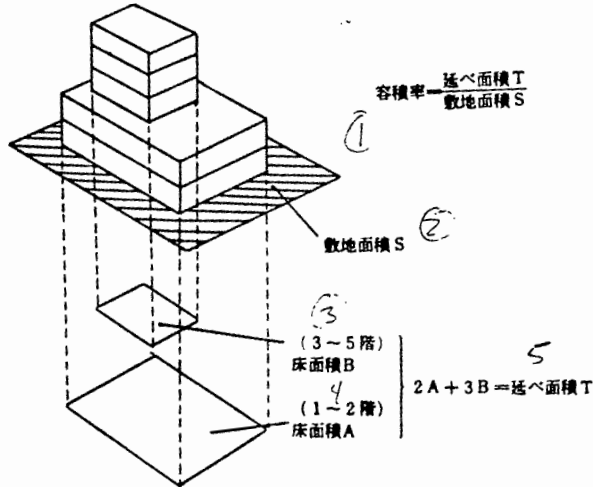

図表 195

① 建築物の容積率の例

③ 敷地一帯に建築する場合

④ 敷地の半分に建築する場合

② 延べ面積の敷地面積に対する割合 1% (容積率 200%)

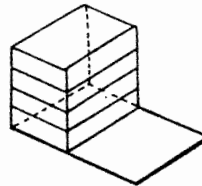
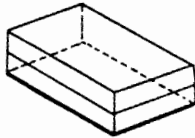

⑤ 延べ面積の敷地面積に対する割合 1% (容積率 500%)

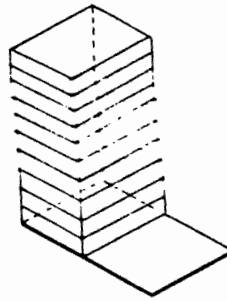
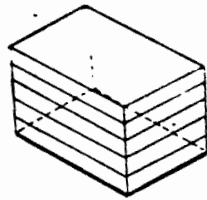

capacity proportion is 500%)

305

Diagram 196 Structure to Lot Proportion

1. Building foundation area
2. Lot surface area
3. Structure/lot proportion

Diagram 197 Limits for the Structure/Lot proportion (Law 53)

1. Conditions for the lot
2. General lot
3. Corner lot authorized by a Special Administrative Branch
4. Area classification
5. Fire resistant structure in a fire prevention district
6. General lot
7. Corner lot authorized by a Special Administrative Branch
8. First class restricted residential area, Second class restricted residential area, restricted industrial area
9. Whichever of these figures is determined by the Urban Plan
10. Residential areas, semi-industrial areas, industrial areas
11. Neighborhood commercial areas, commercial areas
12. Areas with no Land Use Plan authorization (within the districts or areas of the Urban Plan)
13. no restrictions
14. " "
15. Police boxes, public toilets, public walkways and other similar facilities
16. Structures in parks, public squares, roads, that have no hindrances to safety or fire fighting or hygiene, have no restrictions (Law 53 part 4 # 2,3)
17. Supplemental information : In the case where a building's lot sits

図表 196

建 べ い 率

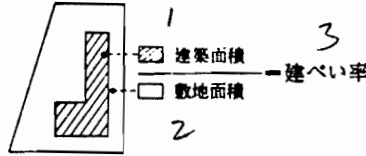

図表 197

建 べ い 率 の 限 度 (法53条)

地域区分 ⁴	敷地の条件等 ¹	② 一般の敷地	③ 特定行政庁の指定する角地等	
			防火地域内の耐火建築物	一般の敷地
第1種住居専用地域 第2種住居専用地域 工業専用地域	3/10, 4/10, 5/10, 6/10のうち、都市計画で定める数値 ⁹ (※)	※+1/10	※+1/10	※+2/10
住居地域 ¹⁰ 準工業地域 工業地域	6/10	7/10	7/10	8/10
近隣商業地域 ¹¹ 商業地域	8/10	9/10	制限なし ¹³	制限なし ¹²
用途地域の指定のない地域 (都市計画区域内) ¹²	7/10	8/10	8/10	9/10

15 ○ 巡査派出所、公衆便所、公共歩廊その他これに類するもの
 16 ○ 公園、広場、道路、川その他これらに類するものうちにある建築物で、安全上、防火上及び衛生上支障がないもの
 17 備考(1): 建築物の敷地が、建べい率の限度の異なる2以上の地域にわたる場合は、それぞれの地域の部分ごとに算出した建築面積の限度の合計が、その敷地全体についての建築面積の限度となる。この場合、実際に建築物をどの地域の部分に建築するかは任意である〔法53条2項〕。

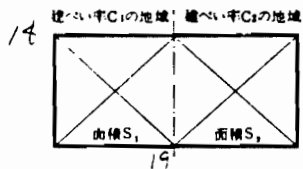

20 この敷地に建築できる建築面積B_xは、

$$B_x = (S_1 \times C_1) + (S_2 \times C_2)$$
 である。
 21 従つて、この敷地の建べい率の限度Cは、

$$C = \frac{B_x}{S_1 + S_2} = \frac{(S_1 \times C_1) + (S_2 \times C_2)}{S_1 + S_2}$$
 となる。

22 備考(2): 敷地が、防火地域とその他の地域にわたる場合、敷地内のすべての建築物が耐火建築物であれば、その敷地全体が、防火地域内にあるものとする〔法53条5項〕。

23 下図のうちでは、③がこれに該当する。

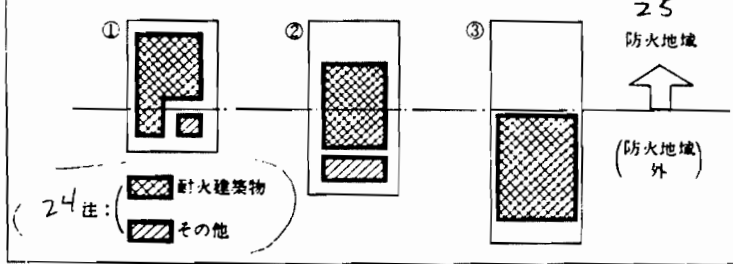

on the border between two areas of differing structure/lot proportion restrictions, the parts that fall in each area should be calculated with their respective formulas and totalled to give the limit for the entire lot. in this case it is up to the individual where he wants to erect his building (Law 53 part 2).

18. Area of structure/lot proportion C_1 , area of structure/lot proportion C_2

19. Area S_1 , area S_2

20. The surface area of the portion of this lot that can be built on is...

21. Accordingly, the structure/lot proportion limit of this area is ...

22. Supplemental information (2): In the case where part of the building's lot is in a fire prevention district and the other part in some other district, and the entire building is made of fire resistant materials, then the entire lot will be considered within a fire prevention district.

(Law 53 part 5)

23. Of the following diagrams, (3) corresponds to this situation.

24. Note: fire resistant structure, other

25. fire prevention area

26. Outside a fire prevention district

Diagram 198 An Example of Allowable Building Area by Structure/lot Proportion

Diagram 199 A Case Where the Setting Back of an Outer Wall (or Column) Is Not Necessary (Order 135-5)

1. Sphere of restriction











2. 1 meter or 1.5m. depending upon authorization

3. Lot borderline

4. Road

5. If the total length of the outer wall (column)'s center lines $(a+b+c+d)$ is less than 3 meters then..

6. (2) If there is a shed or similar structure with a height less than

	3%	
	3%	
	3%	
	3%	
	3%	

図表 199

外壁（又は柱）をセットバックしなくてもよい場合 [令135-5条]

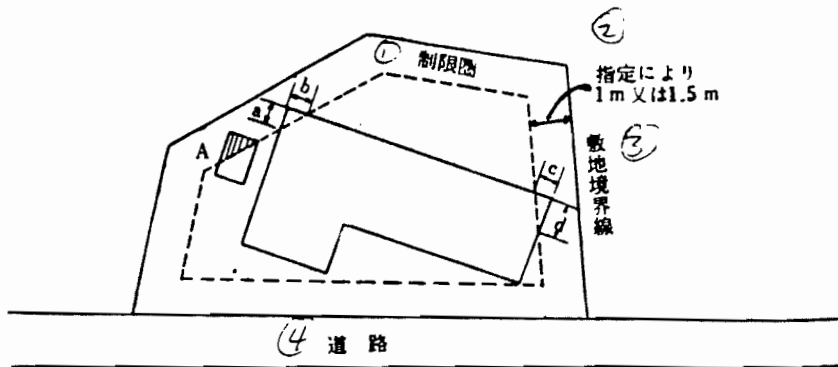

- 5. 1. 外壁（柱）の中心線の長さの合計（ $a + b + c + d$ ）が3m以下の場合
- 6. (2) 物置等の用途のもの(A)で、軒高が2.3m以下、床面積が5㎡以下の場合

less than 2.3 meters and floor space of less than 5 sqm....

Diagram 200 Standards for the Relaxation of Height Restrictions
(10m. to 12m.) in a First Class Residential Restricted Area

1. Required open space on the lot
2. The case of a lot for which the maximum structure/lot proportion has been determined.
3. $\frac{\text{open space area}}{\text{lot area}}$ greater than or equal to $(1-C) + 1/10$
4. Note: Since this example assumes that the lot has been built on to the maximum allowable structure/lot proportion limits, it assumes the minimum amount of open space.
5. This is the case of a lot without a determined maximum structure/lot proportion.
6. $\frac{\text{open space area}}{\text{lot area}}$ greater than or equal to $1/10$
7. Scale of the lot
8. Lot area greater than or equal to 1500sqm., however, it is possible for a Special Administrative Branch to determine regulations for the 750 sqm. to 1500sqm. range.

Diagram 201 Incline Line Height Restriction from the Front-facing Road

1. The scope in which building is permitted
2. Front-facing Road
3. In a first class restricted residential area the height limit is 10 meters, in all other areas there is no restriction on height.
4. First class restricted residential area, Second class restricted residential area, residential area, in all these cases $a = 1.25$.
5. In other cases $a = 1.5$
6. Note: Whenever one building crosses the boundary between two districts, the restrictions of each district apply to each section of

図表 200

第1種住居専用地域内の高さの限度緩和(10m→12m)に関する基準(令130-10条)

① 所要の敷 地内空地	② 建ぺい率の最高限度(C) が定められている敷地の 場合	④ $\frac{\text{空地面積}}{\text{敷地面積}} \geq (1-C) + 1/10$ 注：これは、建ぺい率の限度一杯に建築した場合 の空地面積に「敷地面積の1割」を上乘せし たものを、最低限度としているものである。
	③ 建ぺい率の最高限度が定 められていない敷地の場 合	⑥ $\frac{\text{空地面積}}{\text{敷地面積}} \geq 1/10$
敷地の 規模	敷地面積 $\geq 1500\text{m}^2$ ただし、特定行政庁は規則で、750 m^2 以上1500 m^2 未満の範囲で別に定めるこ とができる。	

図表 201

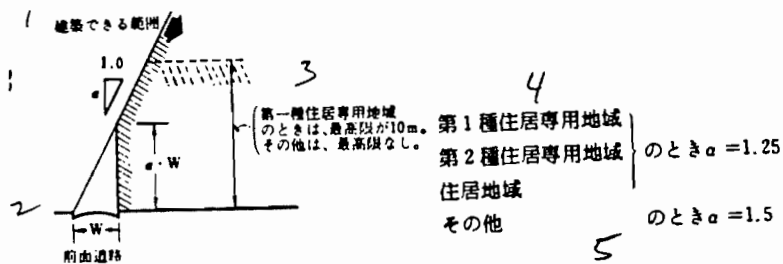

⑥ 注：建築物が制限の異なる地域にわたる場合は、それぞれの地域内に
ある建築物の部分には、それぞれの制限による。

of the building .

Diagram 2o2 Application of Regulations when a Building Crosses the
Borderline between Two Districts with Differing Incline Line Restrictions
(Law 56 part 2)

1. Note: This is also dealt with in part 1 # 1-3 of the same law's
restrictions(Part 4 section (4)-(6) of this book).

2. When a building crosses the borderline between two districts or
areas, the restricitons of those areas will apply to the respective
parts of the building. The following examples are provided for concrete
reference.

3. Note: Although this is not a cross sectional diagram, there are
incline lines to be drawn from the upper and lower neighboring lots, and
so the actual required shape of the building is more complex than it
appears here.

4. Road

5. Neighboring lot

6. Commercial district

7. Residential district

8. Neighboring lot

9. " "

10. Road

11. Commercial district

12. Residential district

13. Scope in which construction is permitted

14. Commercial district

15. Scope of construction allowed in a commercial district

16. Cross section b - b'

17. Scope of construction allowed in residential district

図表 202 建築物が斜線制限の異なる2以上の地域・地区にわたる場合の適用(法56条2項)

① (注: この取扱いは、同条1項1号~3号の制限(本書の第4章④~⑥)について共通である。)

② 建築物が斜線制限の異なる2以上の地域・地区にわたる場合、それぞれの地域・地区内にある「建築物の部分」について、その地域・地区の制限が適用される。

具体的には、下の例を参考にすること。なお、この図には、法56条1項2号の制限も併記してある。

③ (注: 断面に示してないが、上下の隣地寄りの部分には、上・下の隣地境界線からの斜線制限も作用するので、建築物は複雑な形態となる。)

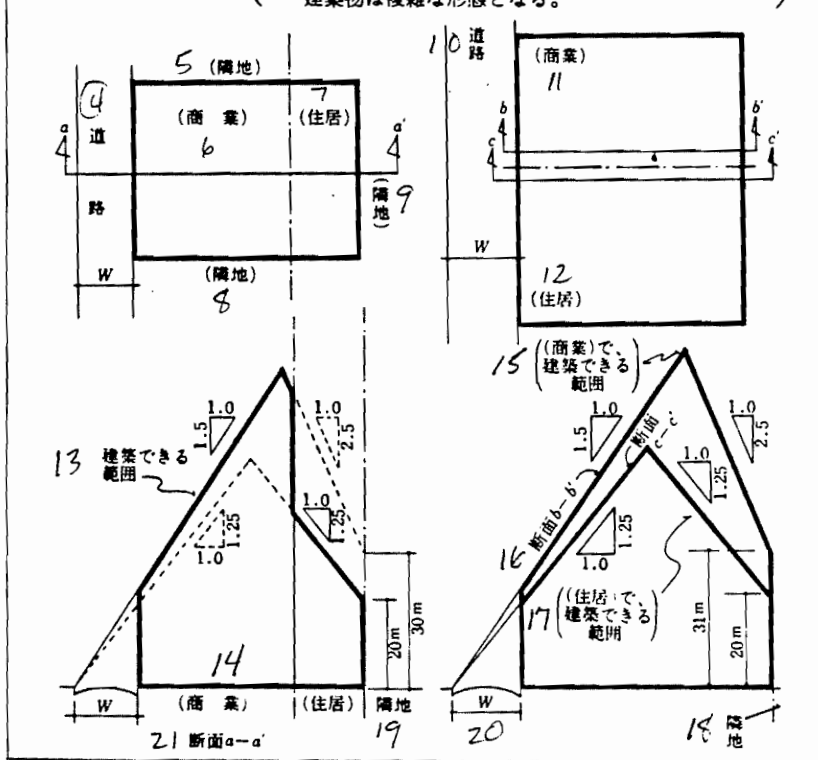

18. Neighboring lot
19. Residential district
20. Neighboring lot
21. Cross section a - a'

Diagram 203 Width of Front-facing Road (Order 132)

1. Section of structure
2. Front-facing road
3. Measured from the borderline of the widest front-facing road, the A part must be within twice the width or 35 meters. While the B part must be over 10 meters from the center line of the other front-facing road.
4. All front-facing roads will be seen as having the width of the widest front-facing road.
5. For parts other than those covered in (1), they (C) must also be within twice the width or 35 meters from the borderline of their respective front-facing roads.
6. The small width front-facing roads will be seen as having the width of the big front-facing roads.
7. Parts (D) other than those covered under (1) and (2)
8. Only the front-facing roads that touch on these parts will be considered front-facing roads.

Diagram 204 The Order of Assumptions for Front-facing Roads
(Order 132)

1. 2 x A or less than 35 meters
2. 2 x B or less than 35 meters
3. 2 x C or less than 35 meters
4. 2 x D or less than 35 meters

Diagram 205 In the Case Where There Are Roads in Front of and Behind the Lot (Order 132)

図表 203

前面道路の幅員 [令132条]

	① 建築物の部分	② 前面道路
①	幅員の最大な前面道路の境界線から、その幅員の2倍以内で、かつ、35m以内の部分④、その他の前面道路の中心線から10mを超える部分⑤	すべての前面道路が、幅員の最大な前面道路の幅員があるとみなす。
②	①以外の部分のうち、それぞれの前面道路の境界線から、その幅員の2倍以内で、かつ、35m以内の部分⑥	幅員の小さい前面道路は、幅員の大きい前面道路の幅員があるとみなす。
③	①、②以外の部分⑦	接する前面道路のみを前面道路とする。

図表 204

前面道路想定順序 [令132条]

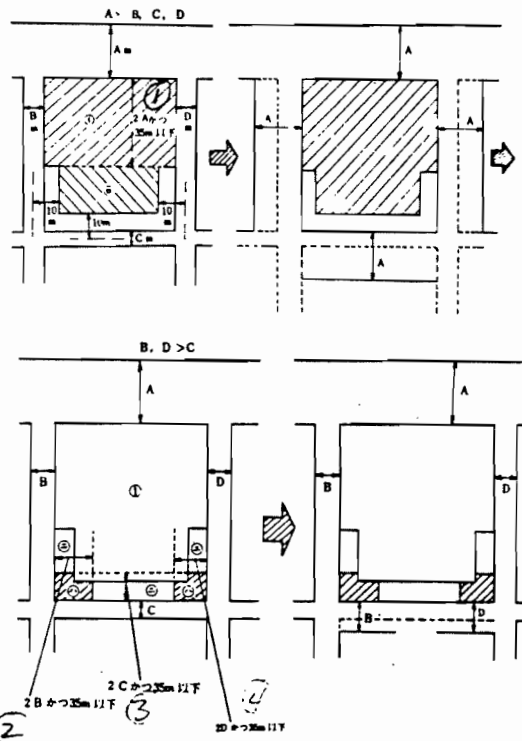

図表 205

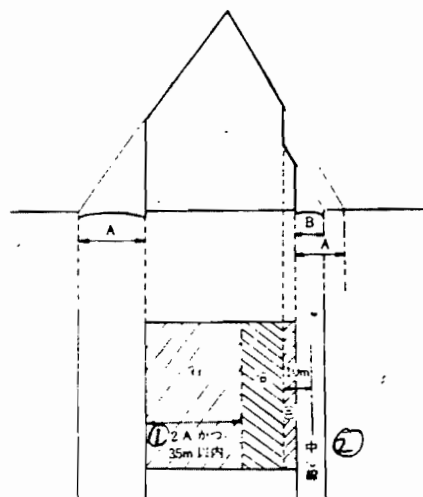

1. 2 x A or within 35 meters
2. Center line

Diagram 206 Dealing with the Case in Which the Otherside of a Front-facing Road is a Park, Public square, or Body of Water (Order 134)

1. The scope in which construction is permissible (1) to (2) can be relaxed.
2. Road
3. Borderline of road
4. To be viewed as borderline of front-facing road
5. Depending upon the area, a may be 1.25 or 1.5
6. Note : Rivers are not viewed as bodies of water, but rather as walls.

Diagram 207 Dealing with the Case in Which There is a Height Difference Between the Front-facing Road and Lot (Order 135-2)

1. The scope in which construction is permissible (1) to (2) can be relaxed.
2. Road
3. Assumed road level

Diagram 208 Incline Line Height Restriction from the Neighboring Lot Borderline(Law 56 part 2 # 1)

1. The scope in which construction is permissible
2. " " " " "
3. Borderline of neighboring lot
4. Second class restricted residential area) in the case of
5. Residential area
6. In other cases
7. Note 1 : There is an absolute limit on building height in a first class restricted residential area and the restriction from this diagram do not apply.
8. Note 2 : If a building crosses the boundary between two districts

図表 206

前面道路の反対側に公園、広場、水面などがある場合の扱い〔令134条〕

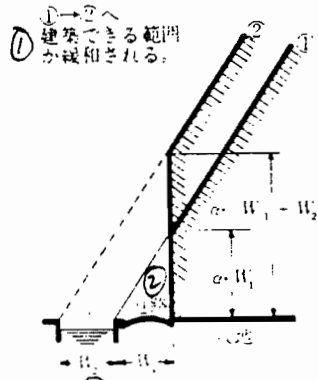

① ①→②へ建築できる範囲が緩和される。

④ ② 道路境界線
前面道路境界線となる

⑤ (令134条に規定)

図表 207

敷地と前面道路に高低差がある場合の扱い〔令135-2条〕

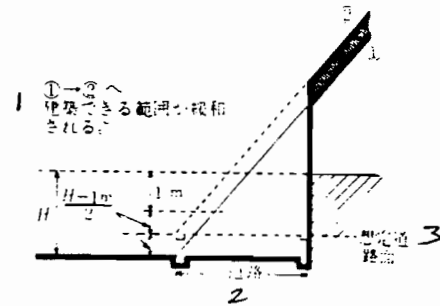

① ①→②へ建築できる範囲が緩和される。

⑥ 注：川などの水面でなく、「壁面線」でも同じ。

図表 208

隣地境界線からの高さの斜線制限
〔法56条1項2号〕

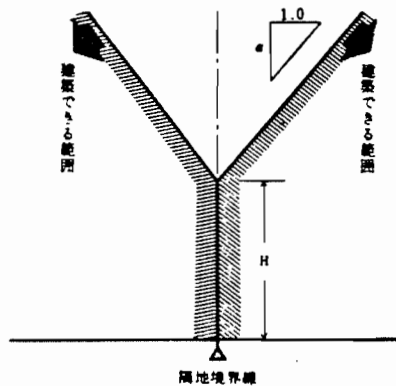

第2種住居専用地域 住居地域	のとき	H=20m $\alpha=1.25$
その他のとき		H=31m $\alpha=2.5$

図表 208 ① 隣地境界線からの高さの斜線制限
 ② [法56条1項2号]

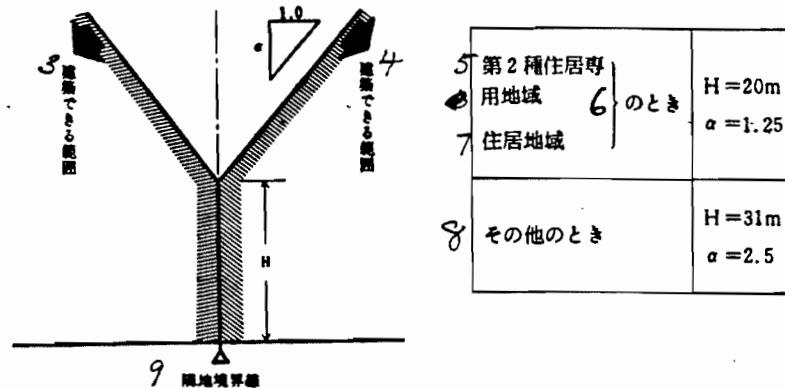

- 10 注1：第1種住居専用地域については、絶対高の制限が10mであり、この図示の制限は適用されない。
- 11 注2：建築物が制限の異なる地域にわたる場合は、それぞれの地域内の建築物の部分は、それぞれの制限による〔法56条2項〕。(図表202参照)

図表 209 隣地境界線からの斜線制限の種類 [令135-3条]
 ① (敷地が公園・広場・水面等に接する場合)

② 管理上の境界内であれば、自由に建築できる範囲

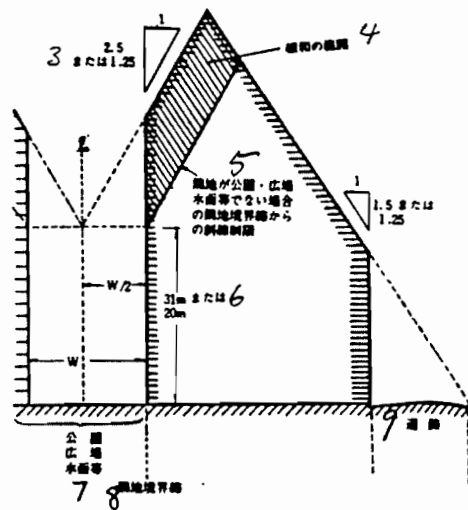
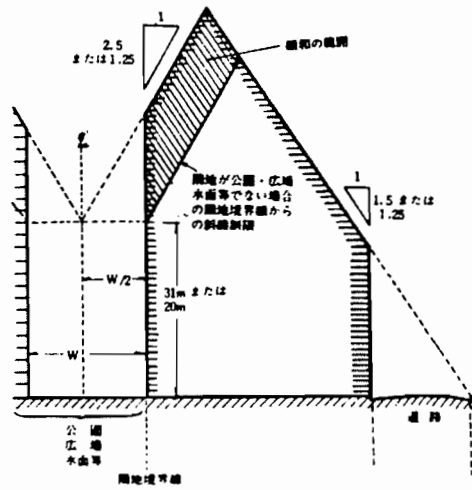

Diagram 208

1. incline line height restriction drawn from the neighboring lot
2. Law 56 part 1 # 2
3. scope in which construction is permissible
4. " " "
5. second class restricted residential
6. in the case of
7. residential area
8. in other cases
9. neighboring lot borderline
10. Note: The absolute height restriction in first class restricted residential areas is 10 meters, thus the restrictions mentioned here do not apply.
11. Note: In the event one lot lies in two different administrative districts each section of the lot shall be covered by the restrictions of the district in which it falls (Law 56 part 2). (see Diagram 202)

Diagram 209 Relaxation of the Incline Line Restriction Drawn from the Neighboring Lot (Order 135-3)

1. When the lot touches on a park, public square, or body of water
2. scope in which construction is permissible within capacity ratio restrictions
3. 2.5 or 1.25
4. scope of the relaxation
5. incline line restriction if lot does not border on park, public square or body of water
6. 31 m or 20 m
7. park, public square, or body of water



図表 210

隣地境界線からの斜線制限の緩和〔令135-3条〕
 (隣地との高低差が著るしい場合)

容積率の限度内にあれば自由に建築できる範囲

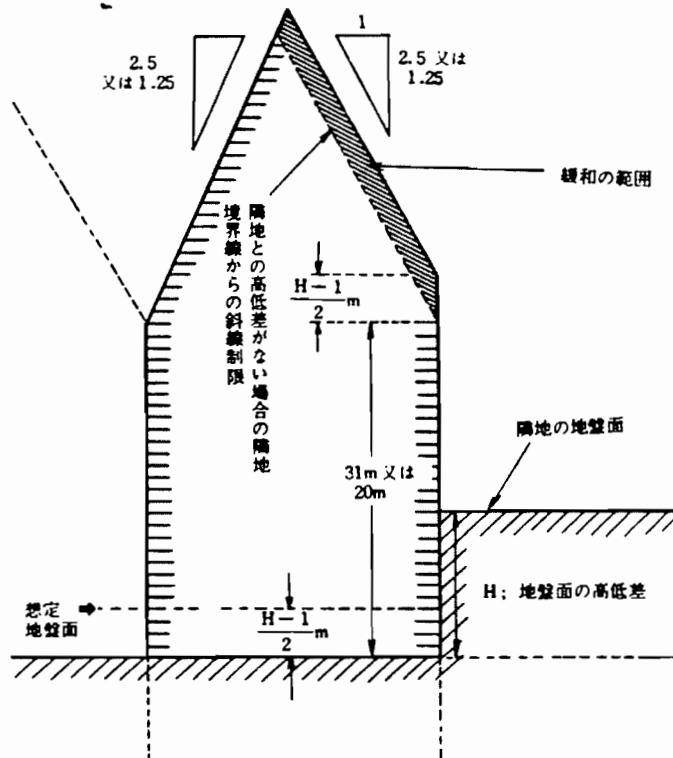

with differing restrictions, then each part of the building will conform to the restrictions of its respective district (Law 56 part 2) (see diagram 202).

Diagram 209 Relaxation of the Incline Line Restriction Drawn from the Neighboring Lot (Order 135-3) (In the case where the lot borders on a park, public square, or a body of water)

- 1. This is the scope of permissible construction, as long as it is within the volume capacity restrictions.
- 2. 2.5 or 1.5
- 3. Scope of relaxation
- 4. This is the incline line restriction drawn from the neighboring lot if that lot is not a park, public square, or body of water.
- 5. 1.5 or 1.25
- 6. 31 meters or 20 meters
- 7. Park, public square, or body of water
- 8. Neighboring lot borderline
- 9. Road

Diagram 210 Relaxation of Incline Line Restriction Drawn from the Neighboring Lot (Order 135-3) (In the case where there is a noticeable difference in height between lots)

- 1. This is the scope of permissible construction, as long as it is within the volume capacity restrictions.
- 2. 2.5 or 1.25
- 3. " "
- 4. Scope of relaxation
- 5. Incline line restriction from neighboring lot when there is no difference in height.
- 6. 31 meters or 20 meters
- 7. Ground level of neighboring lot

8. Difference in ground level heights
9. Assumed ground level
10. Note : It is possible for a Special Administrative Branch to determine separate restrictions for dealing with special ground formations.

図表 210

隣地境界線からの斜線制限の緩和 [令135-3条]

① (隣地との高低差が著しい場合)

② 容積率の限度内にあれば自由に建築できる範囲

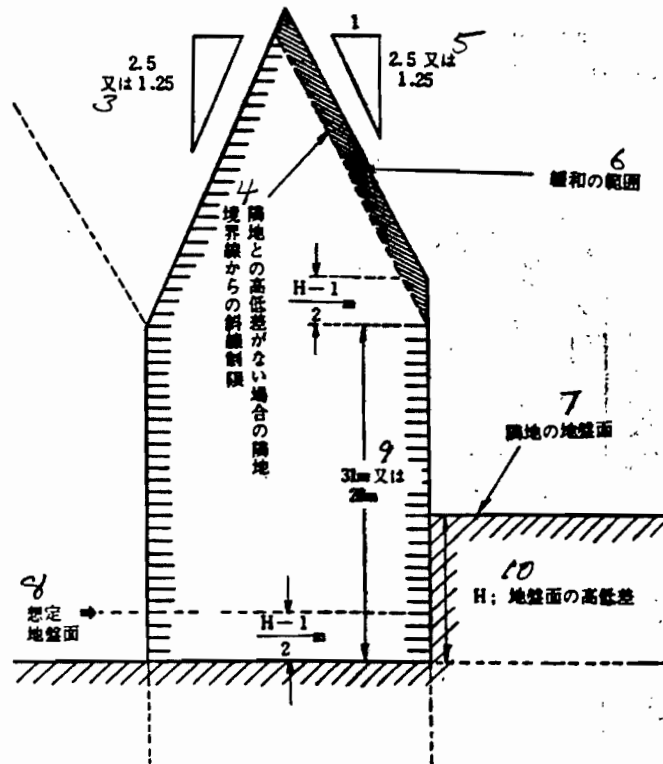

[1] 注：特定行政庁は、地形の特殊性に基づいて、規則で別の取扱いを定めることができる。

8. neighboring lot borderline

323

9. road

Diagram 210 Relaxation of Incline Line Height Restriction Drawn from Neighboring Lot

1. when there is an obvious height difference in the ground level of the two lots
2. scope in which construction is permissible within capacity ratio restrictions
3. 2.5 or 1.25
4. incline line height restriction when there is no clear difference in the ground levels of the two lots
5. 2.5 or 1.25
6. scope of relaxation
7. ground level of neighboring lot
8. imaginary ground level
9. 31 m or 20m
10. difference in ground level heights
11. Note: Based on special land forms, a Special Administrative Branch may determine a different handling of these restrictions.

Diagram 211 Incline Line Height Restriction from the Northern Borderline (Law 56, Order 135-4)

1. first class restricted residential areas
2. second class restricted residential area
3. scope of relaxation when N is the level of a body of water or road
4. scope of permissible construction
5. scope of relaxation when N is the level of a body of water or road
6. excluding 1 to 3 in the separate table of authorizations #3-2 (see

6. Chapter 3 Part 6

Incline Line Height Restrictions for the North Side of First and Second Class Restricted Residential Areas

In particular, there is a restriction established to preserve a good residential environment in these areas. It restricts the incline height from the borderline on the other side of the front facing road from the northern sides of these lots. Also, the relaxation of these restrictions in the case of a lot bordering on a body of water or other open space has been dealt with in the preceding parts 4 and 5 (Law 56, part 1 # 3). In the same way, a borderline within a plan road viewed as a front-facing road will not be considered here.

Figure 211 · Incline Line Height Restriction from the Northern Border (Law 56, Order 135-4)

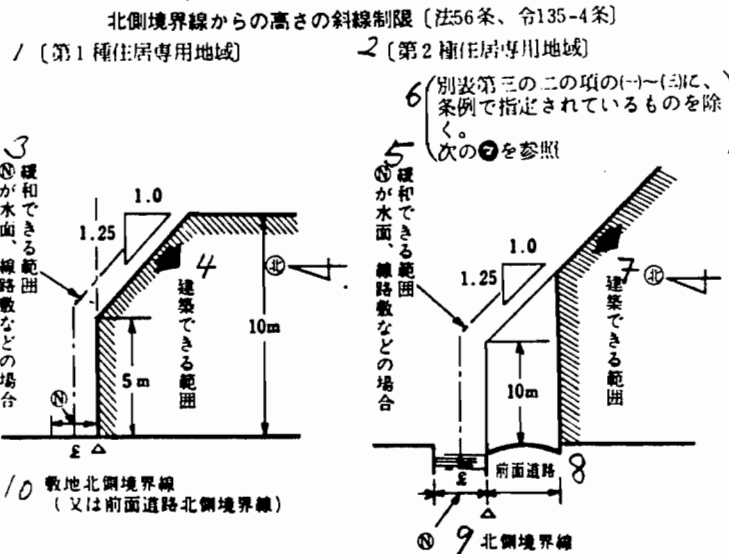

11 注: 建築物が、制限の異なる地域にわたる場合は、それぞれの地域内にある建築物の部分
は、それぞれの制限による(法56条2項)。(図表202参照)

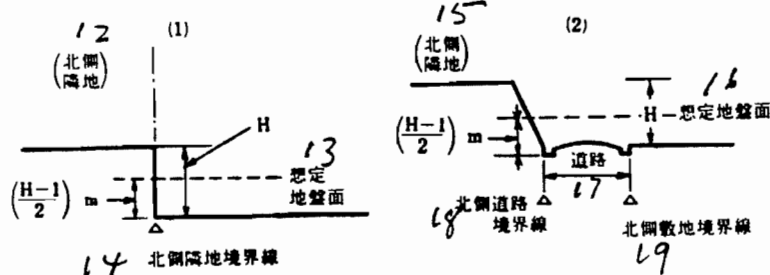

7 Part 7

Height Restrictions for Shade for Middle to High Level Buildings

The intensification of urban land use through middle and high level buildings has advanced hand in hand with the recent rise in urban land density and price increases. As a result of this, there have dev

図表 212 日影による中高層建築物の高さの制限 [法56-2条]

① 地方公共団体が条例で指定する「対象区域」 内の日影規制対象建築物と日影が規制される 水平面(「対象区域」外とその建築物の敷地内 を除く)	② 冬至日の真太陽時による8:00am~ 4:00pm(北海道の区域内では、9:00 am~3:00pm)の間における 日影時間の制限			
	③ 条例で指定 する日影時 間の制限の 区分	④ 水平面A		⑤ 水平面B
		⑥ 北海道 時間	⑦ 北海道 時間	⑧ 北海道 時間
8 一 第一種住居専用地域 制限対象の建築物 10 高さ>7m または、 地上3階以上の 建築物 11 敷地境界線 12 日影規制される 水平面A 13 日影規制される 水平面B 14 平均地盤面 >5m >5m >10m の部分	(一)	<3	<2	<1.5
	(二)	<4	<3	<2.5
	(三)	<5	<4	<2.5
19 二 第二種住居専用地域 制限対象の建築物 20 高さ>10m の建築物 21 敷地境界線 22 日影規制される 水平面A 23 日影規制される 水平面B 24 平均地盤面 >5m >5m >10m の部分	(一)	<3	<2	<1.5
	(二)	<4	<3	<2.5
	(三)	<5	<4	<2.5
26 三 工業専用地域 または、 工業地域 制限対象の建築物 25 平均地盤面 >5m >5m >10m の部分	(一)	<4	<3	<2.5
	(二)	<5	<4	<2.5

- 27 注1: 「平均地盤面」とは、その建築物が周囲の地面と接する位置の平均の高さにおける水平面をいう。
- 28 注2: 同一敷地内に、2以上の建築物があるときは、これらは1つの建築物とみなされて、日影規制が適用される[法56-2条2項]。
- 29 注3: 敷地が道路、川、海等に接する場合、敷地と隣地に著しい高低差がある場合等、特別の条件のある場合についての緩和措置は図表215参照。
- 30 注4: 「対象区域」外にある建築物(高さ>10m)でも、冬至日に「対象区域」内に日影を生じさせるものは、「対象区域」内の建築物と見なされて、日影規制が適用される。
- 31 注5: ①制限対象(上表の図参照)の建築物が日影時間の制限の異なる区域の内外にわたる場合、又は、②冬至日に対象区域のうち当該建築物がある区域外の土地に日影を生じさせる場合にはそれぞれ制限対象建築物が日影を生じさせる各区域内にあるものとして、日影規制を適用する[令135-4-3条]。

7. scope of permissible construction
8. surface of road
9. northern borderline
10. northern borderline of lot (or northern border facing road)
11. Note: when a single lot falls between two districts with different restrictions then each section of the lot shall be covered by the rules of the district in which it falls (Law 56 part 2) (see Diagram 202)
12. northern lot
13. imaginary ground level
14. northern borderline
15. northern lot
16. imaginary ground level
17. road
18. northern road borderline
19. lot's northern boundary

Diagram 212 Shade Related Height Restrictions for Middle and High Level Buildings (Law 56-2)

1. Level surface area shade restrictions designated for "Shade districts" authorized by local public bodies
2. full sun at winter solstice 8:00 to 4:00 (in Hokkaido 9:00 to 3:00) shade time restrictions
3. division of shade time restrictions authorized in the regulations
4. level surface area A
5. level surface area B
6. Hokkaido
7. "
8. first class restricted residential area
9. building that is object of shade restrictions
10. roof height, roof height greater than 7m or more than 3 stories

11. lot boundary line
12. level surface area restricted by shade time A
13. " " " " " " B
14. average ground level, portion between 5m and 10m, portion greater than 10m
15. time
16. "
17. "
18. "
19. second class restricted residential area
20. building that is object of shade restrictions
21. lot boundary line
22. level surface area restricted by shade time A
23. " " " " B
24. height over 10m
25. average ground level, portion between 5m and 10m, portion greater than 10m
26. residential areas, neighboring commercial area, semi-industrial areas and districts
27. Note 1 : "average ground level" indicates the average height of the land surrounding the building on all sides.
28. Note 2 : When there are more than buildings on a single lot then so far as the shade restrictions are concerned they will be treated as one building (Law56-2 part 2).
29. When the lot either borders on a road, river, ocean, or when there is a clear difference in height between two neighboring lots, special measures are used to relax the restrictions. (see Diagram 215)
30. Note 4 : Even buildings outside the "shade restriction" district

will be covered by these regulations when over 10m height and conforming to the conditions of the restrictions.

31. Note 5 : (1) when a lot falls between two districts of different shade restriction regulations or (2) when, on winter solstice the shade from a building in a shade restriction district falls on buildings outside the district, then in both cases the entire area concerned will be covered by the restrictions in the original district (Order 135-4-3).

Diagram 213 Time Chart for Shade Restrictions (example)

1. planned building

2. Note: lines for 30 minute intervals have been abbreviated.

Diagram 214 Chart for Shade Time Classification (example)

1. 2 hrs. shade

2. 3 hrs. shade

3. 4 hrs. shade

4. 5 hrs. shade

5. planned building

6. Note: 1.5 hrs. and 2.5 hrs. should be abbreviated

Diagram 215 Relaxation of the Shade Related Height Restriction (Order 135-4-2)

1. In the event a lot borders on a road, body of water, or railroad bed then the boundary will be seen to be at one half of of the width of these structures (Order 135-4-2). Note: If this lot in question borders on a park or some other open area to needs sunlight then this relaxation will not be allowed. a. In the case of the roads width being less than 10m

2. lot boundary

3. " "

4. road (or body of water or railroad bed)
5. opposite side border line
6. relaxation (5m position)
7. " (10m position)
8. lot boundary
9. cross-section of A-A'
10. lot boundary line
11. relaxation of lot boundary line
12. opposite edge boundary line
13. shade restriction surface area
14. first class restricted residential 1.5m/other 4.0m
15. first 5m position
16. relaxed 5m position
17. first 10m
18. relaxed 10m
19. b. In the case of the roads width being greater than 10m
sub diagram 1 closed format
20. road width
21. 10m line (before relaxation)
- 212 5 m line (before relaxation)
23. 10m line (after relaxation)
24. 5m line (after relaxation)
25. lot
26. relaxed lot boundary
27. sub diagram 2 spread direction format
28. 10m line
29. direction of spread
20. 5m line
31. lot

32. when road width is greater than 10m this equals 5m
33. relaxed boundary line
34. 5m line (after relaxation)
35. 10m lune (after relaxation)
36. road width
37. the post relaxation 5m and 10m lines in sub diagram 1 are closed while those in sub diagram 2 are not closed.
38. This shape of the border lines was determined by the position of the lot boundaries according to a formal interpretation of the law. It results in the scattered pattern of sub diagram 2.
39. Since the relaxation only involved moving the opposite side border line in sub diagram 1, it retains its closed shape.
40. The strict interpretation of sub diagram 2 has given way to an abbreviated interpretation.
41. According to the format in sub diagram 2, if the road should run from East to West it would result in a broad relaxation of restrictions and a small lot might be completely shaded by the 10m relaxation .
42. The reason for displaying both of these formats together is that Special Administrative Branches encourage only the first format outlined in sub diagram 1.
43. In the event that the average height of a given lot is more than 1m less than that of a neighboring lot, then the level surface area of the lot will be determined by the formula $\frac{\text{height difference} - 1\text{m}}{2}$.
(Order 135-4-2)
44. lot average level surface area
45. shade restriction surface area first class restricted residential
1.5m other 4.0m
46. average ground level

図表 213

時刻別日影図 (例)

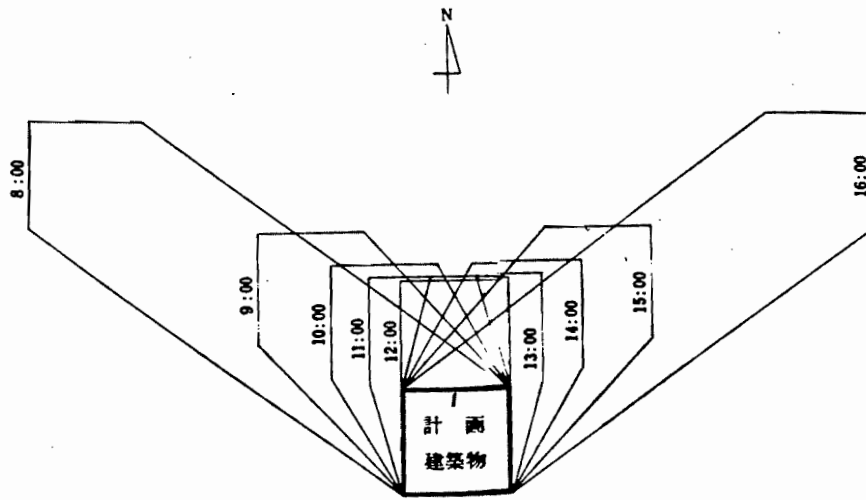

図表 214

等時間日影線図 (例)

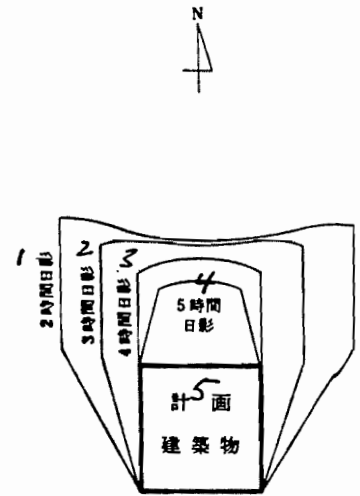

2 注: 各太陽時の中間 (30分) については、省略。

6 注: 1.5時間、2.5時間については、省略。

図表 215

- ① 敷地が、道路・水面・線路敷などに接する場合: それらの幅の $1/2$ だけ、敷地境界線が外側にあると見做す。〔令135-4-2条1項1号〕
- 注: 公園など日照が必要な空地に接する場合などは、この緩和の対象とならない。
- イ、道路巾は $W < 10m$ の場合

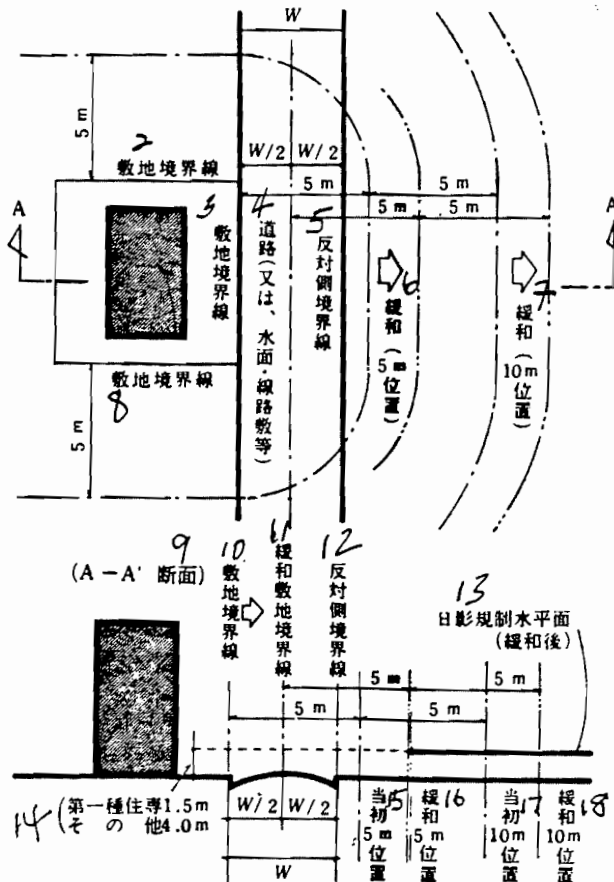

19

ロ、道路巾員 $W \geq 10m$ の場合

図1. 閉鎖方式

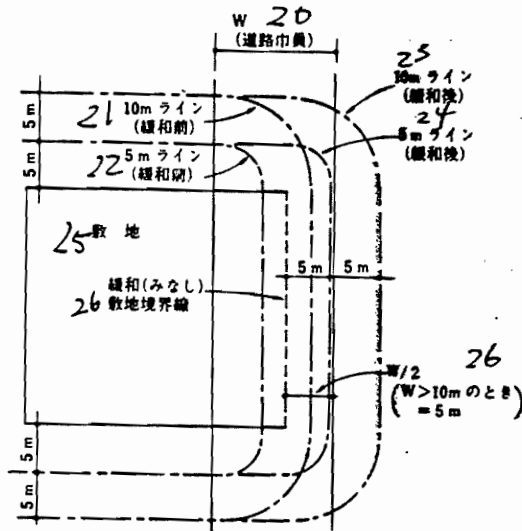

27

図2. 発散方向方式

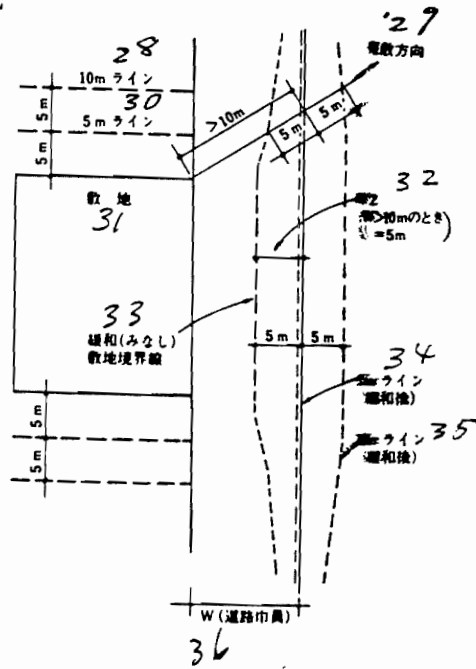

- 37 備考 図1では、緩和後の5mライン・10mラインは、閉鎖しているが、図2では、これらの線は閉鎖していない。
- 38 図2では、正式な法解釈に基づく、発散方向による敷地境界線のみなし方（位置の定め方）をしたために、このような形となったものである。
- 39 図1では、単純に敷地境界線を前面道路の反対側境界線の側にも移動したために、5mライン・10mラインが閉鎖する形となったものである。いわば、
- 40 図2の厳密解（答）に対し、簡略解（答）といってよい。
- 41 図2の方式では、かりにこの道路が東西に走っているとすると、東西方向の規制が大巾に緩和される結果、小さい敷地に細分された場合、複合日影により、建築物のすきまからの日照が妨げられるおそれがある。（すきま日照は、とくに、10mライン規制の狙いと考えられる）
- 42 これが二図を併記した理由であるが、ちなみに、図1の方法を勧奨している特定行政庁もあるようである。

② 敷地（平均地盤面）が、隣地又は隣地に接続する土地（日影の生ずるもの）の地盤面より1m以上低い場合：敷地（平均地盤面）は、「その高低差-1m）/2」だけ高い位置にあるものと見做す。〔令135-4-2条1項2号〕

44 イ 敷地の平均地盤面

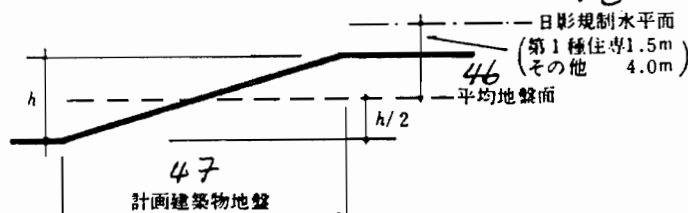

48 □ 高低差のある隣地に接する場合の規定地盤面

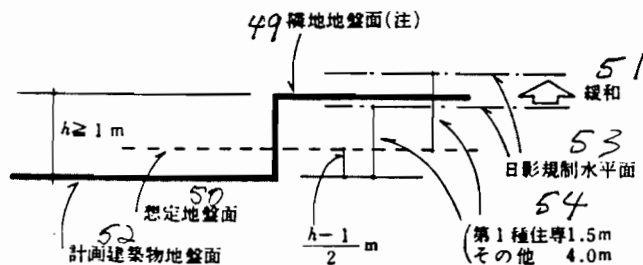

55 注：隣地に建築物がないときは、その「地盤面」は平均地表面とする。

56 ハ 高低差のある隣地の接続土地に対する規定地盤面

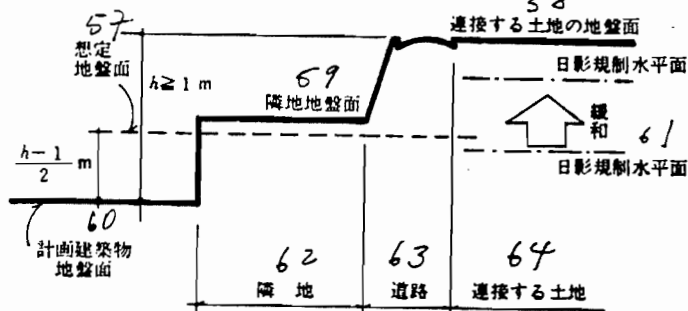

65 注：道路・河川等を隔てている場合も、「接続」に含まれる。
接続する土地に建築物がないときは、その「地盤面」は平均地表面とする。

47. planned building's base
48. b. ground level surface area restrictions for lots with pronounced height differences
49. neighboring lot ground level (note)
50. imaginary ground level
51. relaxation
52. planned building's base area
53. shade restriction level area
54. first class restricted residential district 1.5m other 4.0m
55. Note: if there is no structure in the neighboring lot then use the average ground level area.
56. c. Ground level regulations when there are a series of connected lots with height differences
57. imaginary ground level
58. base area of connected lots
59. neighboring lot base level
60. base area of planned building
61. relaxation shade restriction level
62. neighboring lot
63. road
64. connected lot
65. Note: In the case of lots split by roads or rivers, they are still considered connected. If there is no structure in the neighboring lot then use the average ground level area.

Diagram 216 Standards for Scale and Open Spaces in Lots for Buildings
Designed under a Common Plan's Framework (Order 136)

1. lot's necessary open space
2. in the case of lots with a maximum structure/lot ratio already

developed continual disputes over the spatial relationships of buildings not only in the larger urban areas, but also in cities throughout the nation. In this respect, the sunlight problem has been called the biggest problem, however, in reality, it is just a problem of sunlight than the fact that the problems of over crowded urban areas have come to be represented by the role of struggles over sunlight rights.

Since it would not necessarily be best to restrict building to lowlevel structures in crowded areas to regulate sunlight, in this section we will deal exclusively with middle and high level buildings and treat the regulations therein prescribed as the solution to this problem.

Since shade is created by middle and high level buildings blocking the sun, and depends on the height, shape, position, etc. of the building, and these will differ from building to building, and since the height and position of the sun will change with time (and depending on the angle of the building, season, and time) it cannot be denied that the influence of these factors is difficult to grasp.

First in this chapter we will take up the question of these restrictions in First class, Second class and regular Residential Areas Neighborhood Commercial Areas and semi-Industrial Areas Then we will establish standards for the surface areas to be covered under the shade time restrictions according to the particular characteristics of the area (in other words, how much area should be guaranteed sunlight), and then use the amount of sun at the winter solstice as a standard time framework for all relevant calculations.

The full sun time will be taken to mean the time the sun crosses the meridian, and when that differs from noon standard time the following formula will be used to determine the new value.

full sun time = central standard time + average time difference + $\frac{L - 135^{\circ}}{15^{\circ}}$

Note: L is the latitude of the given area

Concretely speaking, the sunlight restriction system outlined in this section will be applied to various districts by the local public groups, furthermore discrepancies in the shade time limits will be dealt with by the rules thus authorized (Law 56-2).

8. Other (Misc.)

(1) High Level Districts

A high level district is designated within a zone and its purpose is either to protect the towns' environment or to stimulate land use. The contents of these regulations determined by the Urban Plan are either to restrict the height of buildings within the district (absolute height limit) or to establish a minimum height or to do both depending on the case at hand (Urban Planning Law 8, 9; Law 58).

(2) High Use District

As concerns urban land within zoning districts, particularly when there is a need for either improving urban functions or rationalizing land use, the high use district may be established under the authority of the Urban Plan. This sets limits, both high and low, on the capacities of lots as well as setting structure/lot ratios and the position of walls within the lots (Urban Planning Law 9 part 11). This type of district is different from all others in that a specified degree of land use is required as a duty of all those building within its boundaries. This restriction is determined on a district to district basis by the Urban Plan (Law 59, Urban Planning Law 8, #2e).

The cases in which the above restrictions on land use do not apply are as follows.

1. If the structures are to be built of wood, steel framed, or of concrete blocks, and are easily breakdownable 2 or less storied buildings.

assembled from concrete blocks, and are of a construction which is easy to breakdown, and of two or less stories (basements not allowed).

2. Public toilet facilities, policemen patrol boxes, or other structures deemed necessary from the point of view of public welfare.

3. Schools, train stations or other structures deemed necessary from the point of view of public welfare that have received authorization from a Special Administrative Branch.

In the event of an open space on a given lot touches on the front-facing road, then where the Special Administrative Branch determines that there is no threat to Traffic, Safety, Fire-fighting, Hygiene then the incline line height restriction will not be applied.

(3) Special Examples for General Design Urban Structures

Structures that will improve the state of urban environmental facilities, for example the construction of a fountain, gardens, sidewalks, etc. in an open space, when their shape and style accord with their surroundings and they are opened to the public, are very desirable for crowded urban areas.

Where these open spaces and lot surface areas conform to the standards established in Diagram 216, and pose no threat either to traffic, safety, fire fighting, or hygiene, and can be shown to be beneficial to the urban environment, then with the permission of a Special Administrative Branch, the restrictions on land use capacity (Law 52 part 1,2) and the height restrictions for first class restricted residential areas (Law 55 part 1) and the incline line height restriction (Law 56) may be relaxed (Law 59-2).

1 所要の 敷地内 空地	2 建ぺい率の最高限度 (C) が定められている敷地の場 合	3 建ぺい率の最高限度 (C) 〔法53条〕	4 空地面積 / 敷地面積
		$C \leq 5/10$	$\geq (1-C) + 1.5/10$
		$5/10 < C \leq 5.5/10$	$\geq 6.5/10$
		$5.5/10 < C$	$\geq (1-C) + 2/10$
	5 建ぺい率の最高限度が定められていない敷地の場合		$\geq 2/10$
6 敷地 の最 低規 模	7 地域・区域	8 敷地面積の 規模 (㎡)	9 特定行政庁が規則で、別に定める 場合の数値の範囲 (㎡)
	第1種住専 10	$\geq 3,000$	$1,500 \leq \text{数値} < 3,000$
	第2種住専・住居・準工・工 業・工専 12	$\geq 2,000$	$1,000 \leq \text{数値} < 2,000$
	近隣商業・商業 14	$\geq 1,000$	$500 \leq \text{数値} < 1,000$
	用途地域未指定 16	$\geq 2,000$	$1,000 \leq \text{数値} < 2,000$

determined

3. structure/lot ratio maximum value (Law53)
4. open space area/lot area
5. in cases where the structure/lot ratio is undetermined
6. smallest scale of lot
7. area district
8. scale of lot surface area
9. separate values from a scope determined by Special Administrative Branch
10. first class restricted residential area
11. value
12. second class restricted residential area, residential area, semi-industrial, industrial, restricted industrial area
13. value
14. neighborhood commercial, commercial areas
15. value
16. area of unspecified land use
17. value

Diagram 217 Chart of Shape Restrictions

1. zone
2. first class restricted residential areas
3. second class restricted residential areas
4. residential areas
5. neighborhood commercial areas
6. commercial areas
7. semi industrial areas
8. industrial areas
9. restricted industrial areas

Diagram 216 Standards for Open Spaces and and Lots in General
Design Urban Structures (Order 136)

↓ 所要の 敷地内 空地	3 建ぺい率の最高限度(C) 〔法53条〕		4 空地面積 / 敷地面積
	2 建ぺい率の最高限度 (C) が定められている敷地の場 合	$C \leq 5/10$	$\geq (1-C) + 1.5/10$
		$5/10 < C \leq 5.5/10$	$\geq 6.5/10$
		$5.5/10 < C$	$\geq (1-C) + 2/10$
5 建ぺい率の最高限度が定められていない敷地の場合			$\geq 2/10$
6 敷地 の最 低規 模	7 地域・区域	8 敷地面積の 規模 (㎡)	9 特定行政庁が規則で、別に定める 場合の数値の範囲 (㎡)
	第1種住専 10	$\geq 3,000$	11 $1,500 \leq \text{数値} < 3,000$
	第2種住専・住居・準工・工 業・工専 12	$\geq 2,000$	13 $1,000 \leq \text{数値} < 2,000$
	近隣商業・商業 14	$\geq 1,000$	15 $500 \leq \text{数値} < 1,000$
	用途地域未指定 16	$\geq 2,000$	17 $1,000 \leq \text{数値} < 2,000$

(4) Special Districts

In construction plans for improving urban areas that use blocks, or even "super blocks" as a unit of planning for a synthesized, integrated district section, it is not always best to stick to the restrictions established for individual lots, furthermore, since the number of these sorts of projects can be expected to increase in the future a "special district" classification has been created to deal with this sort of problem.

There are separate classifications for restrictions on capacity, height, outer walls (or columns) determined in these districts. Also, it is possible to skip over the first and second restrictions enumerated in this section's 1-7 (Urban Planning Law 8, 9 ; Law 60).

(5) Conclusion

The major articles covering capacity, height, structure/lot ratios are basically covered in the following summation of the restrictions listed in this section.

図表 217

		形 態 制 限 一 覧									
用途地域		1	2	3	4	5	6	7	8	9	10
制限項目	制限項目	第1種住居 専用地域	第2種住居 専用地域	住居 地域	近隣商 業地域	商 業 地 域	準工業 地 域	工業 地 域	工業専 用地域	用途地域の指定 のない地域(都 市計画区域内)	
12 容積率(%) (注2)	12	※ 50, 60 80, 100 150, 200	※ 100, 150 200, 300	※ 200, 300, 400	※ 400, 500 600, 700 800, 700 1000	※ 200, 300, 400	※ 30, 40 50, 60	※ 70	※ 400		
13 建ぺい率(%)	13	※ 30, 40, 50, 60	60	80	60	70					
14 斜 線 制 限	15 前面道路斜線 (勾配)	1.25 1			1.5 1						
	16 隣地斜線 (立ち上がり +勾配)	—	20M + $\frac{1.25}{1}$		31M + $\frac{2.5}{1}$						
	17 北側斜線 (立ち上がり +勾配)	5M + $\frac{1.25}{1}$	10M + $\frac{1.25}{1}$ (注3)	—	—						
18 高さの 限度	18	10M (注4)	—	—	—						
19 敷地境界線からの 壁面後退	19	※1M ※1.5M	—	—	—						

- 20 注1：※印を付けた制限は都市計画で定めるものを示す。
- 21 注2：前面道路の幅員によるものについては、図表193参照。
- 22 注3：日影規制対象区域内を除く。
- 23 注4：特定行政庁が認めたものは、12m。

10. areas of unspecified land use
11. item of restriction
12. capacity (note 2)
13. structure/lot ratio
14. incline line restriction
15. incline line drawn from front-facing road
16. lot boundary incline line
17. northern border incline line
18. height restriction
19. setting back of outer wall from lot boundaries
20. Note 1 : ✖ symbol indicates the restriction is determined by the Urban Plan
21. Note 2: See Diagram 193 concerning the width of roads
22. Note 3: with the exception of buildings within a shade restrictiob district.
- 23/ Note 4 : Special Administrative Branches Recognize 12m.

Diagram 218 Incline Line Restrictions Drawn from a Front-facing Road or Neighboring Lot's Boundary

1. (neighboring commercial areas, commercial areas, semi-industrial areas, restricted industrial areas and industrial areas)
2. open space in which no construction is permitted
3. neighboring lot incline line
4. road incline line
5. open space in which no construction is permitted
6. road width
7. building
8. "

218

前面道路及び隣地境界線からの斜線制限

1 (近隣商業、商業、準工業地域、工業専用、工業の場合)

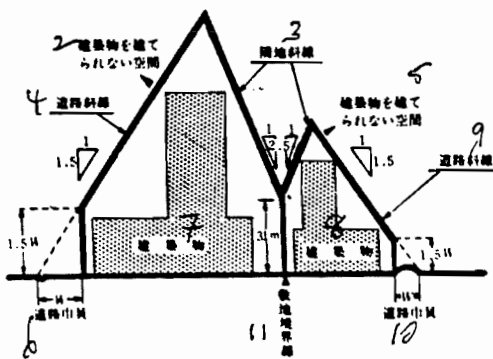

CHAPTER III**SECTION V FIRE ZONES**~~Chapter 3 Section 5~~ Fire-proof DistrictsPart 1 Definition of the Fire-proof District System

As concerns fires, the first thing is to see to it that they never start, but if a fire should by some unfortunate circumstance break out, then naturally the most important thing is to stop in its early stages before serious damage can occur. At the same time it is essential that in the event of an emergency evacuation must take place swiftly and safely. The essential points concerning these matters have already been covered in Chapter 2, and have nothing to do with the position of the building. Regulations are determined by the use and scale of a given building.

In addition there are regulations established to see to it that once a fire has broken out in one building it does not spread to neighboring structures. These regulations are designed to cover groups of buildings and are an important feature of urban fire fighting planning; they comprise the fire fighting area system.

In other words, where the concentration of buildings is greatest in the heart of a city these regulations will stimulate the construction of fire resistant structures. Also, in the area between the heart of the city and its suburbs the semi fire fighting district designation will work to encourage the use of fire resistant materials and structures wherever possible.

Fire fighting districts and semi fire fighting districts are designated by urban or municipal governments with the approval of prefectural governors (Urban Planning Law 8, 9)

There is also a system of regulations restricting the construction of roofs and walls in areas outside the boundaries of fire fighting and semi fire fighting districts (including areas outside of urban plans). They are authorized by a Special Administrative Branch.

(Law 22-24)

(2) Construction Restrictions Within Fire Fighting and semi Fire Fighting Districts

a. Restrictions on buildings within a fire fighting district (Law61)

Diagram 219

1 対 象	構 造
③ 階数が3以上又は延べ面積が100㎡を超える建築物 ①	4 耐火建築物 5
② その他の建築物 6	③を除く 耐火建築物又は簡易耐火建築物 7
⑧ 1 外壁及び軒裏が防火構造で延べ面積50㎡以内の平家建附属建築物 ⑨ 2 主要構造部が不燃材料で造られた卸売市場の上家又は機械製作工場の類 ⑩ 3 不燃材料で造り又はおおわれた高さ2mを超える門及びへい ⑪ 4 高さ2m以下の門及びへい	12 制限なし

Also, the major parts of structures like signs, advertizment towers, structures built on roofs or taller than 3 meters must be made of non combustibile materials (Law 66).

b. Restrictions on buildings in semi fire fighting districts (Law 62).

Diagram 220

1 対 象	構 造
③ 地階を除く階数が4以上又は延べ面積が1,500㎡を超える建築物 ①	4 耐火建築物 5
⑦ 地階を除く階数が3又は延べ面積が500㎡を超え1,500㎡以下の建築物 ②	④を除く 耐火建築物又は簡易耐火建築物 6
①、②以外の木造建築物 ⑧	⑨ 外壁及び軒裏で延焼のおそれのある部分 10 防火構造
③	⑪ 高さ2mを超える附属の門又はへいで延焼のおそれのある部分 不燃材料で造るか、おおう。 12

9. road incline line
10. road width
11. lot borderline

Diagram 219

1. object
2. structure
3. buildings with over three stories or an extended surface area of over 100 sqm.
4. however (3) is excepted
5. fire resistant structures
6. other buildings
7. fire resistant or partially fire resistant buildings
8. Houses or their attached structures, outer walls and eaves made of fire proof materials
9. machine rooms or markets whose major parts are made of non-combustible materials
10. gates and fences either made of non-combustible materials or over 2 meters height
11. gates and fences over 2m tall
12. no restrictions

Diagram 220

1. objetc
2. structure
3. excluding the ground floor, structures with over 4 stories or an extended suface area of over 1,500 sqm.
4. however, this excludes machine rooms of markets whose major parts are made of non-combustible materials

Diagram 219

1 対 象		構 造 2
3 ①	階数が3以上又は延べ面積が100㎡を超える建築物	4 ただし、 5 耐火建築物
②	その他の建築物 6	③を除く 7 耐火建築物又は簡易耐火建築物

8 9 10 11	<p>8 1 外壁及び軒裏が防火構造で延べ面積50㎡以内の平家建附属建築物</p> <p>9 2 主要構造部が不燃材料で造られた卸売市場の上家又は機械製作工場の類</p> <p>10 3 不燃材料で造り又はおおわれた高さ2mを超える門及びへい</p> <p>11 4 高さ2m以下の門及びへい</p>	12 制限なし
--------------------	--------------------------------------------------------------------------------------------------------------------------------------------------------	------------

Diagram 220

対 象		構 造 2
1	地階を除く階数が4以上又は延べ面積が1,500㎡を超える建築物	ただし、主要構造部が不燃材料で造られた卸売市場の上家又は機械製作工場の類を除く。 耐火建築物
2	地階を除く階数が3又は延べ面積が500㎡を超え1,500㎡以下の建築物	耐火建築物又は簡易耐火建築物
①、②以外の木造建築物	外壁及び軒裏で延焼のおそれのある部分	10 防火構造
3	高さ2mを超える附属の門又はへいで延焼のおそれのある部分	不燃材料で造るか、おおう。

5. fire resistant buildings
6. fire resistant or partially fire resistant structures
7. excluding the ground floor, buildings with either 3 stories or over 500 but under 1,500 sqm.
8. wood structures other than (1) and (2)
9. outer walls or eaves for which there is a threat of a fire's spreading
10. fire proof structure
11. attached gate or wall for which there is a threat of a fire's spreading
12. build from non-combustible materials

Diagram 221

1. fire fighting district
2. semi-fire fighting district
3. fire fighting district
4. area with no specified authorization
5. " " "
6. semi-fire fighting district
7. fire wall
8. building falls under fire fighting restrictions
9. building falls under semi-fire fighting restrictions
10. building falls under no restrictions

Diagram 222 Scope of Alterations and Additions on Already Existing Buildings (Order 137-7, 137-8)

1. case of fire fighting district
2. case of semi-fire fighting district

1. Roofs-- if not fire resistant, structures must use non-combustible materials in building roofs (Law 63)
2. Entrance to an outer wall-- in sections where there is a chance of fire spreading, a fire door or some other fire fighting equipment must be provided (Law 64).
3. Outer wall on lot borderline-- the wall can be built on the borderline only if it is of fire resistant materials (Law 65).
3. Other
 - a. Measures in the event that the lot sits between a fire fighting district or semi fire fighting district and some other district

In the event of a lot that straddles a fire fighting or semi-fire fighting district, then, with the exception of those lots with a fire wall dividing the lot from the district, the entire lot must strictly conform to the requirements of the fire fighting district (Law 67).

Diagram 221

図表 221

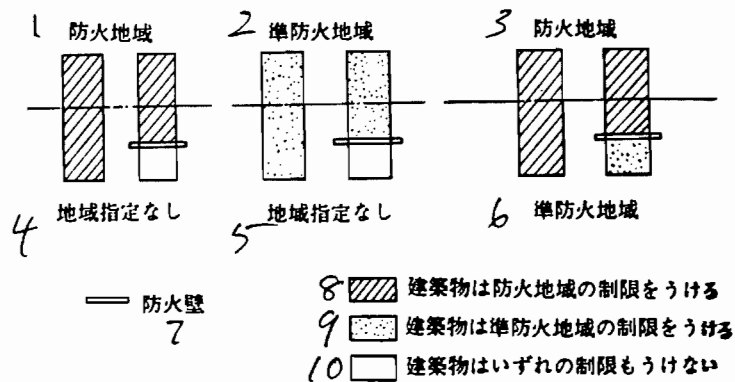

- b. Measures for already existing structures

In the event of expanding or re-modeling a building which was already standing at the time of the fire fighting or semi fire fighting district designation, and which does not comply with the provisions set forth in part 2 of this section (Law 61 or 62 part 1) the

図表 221

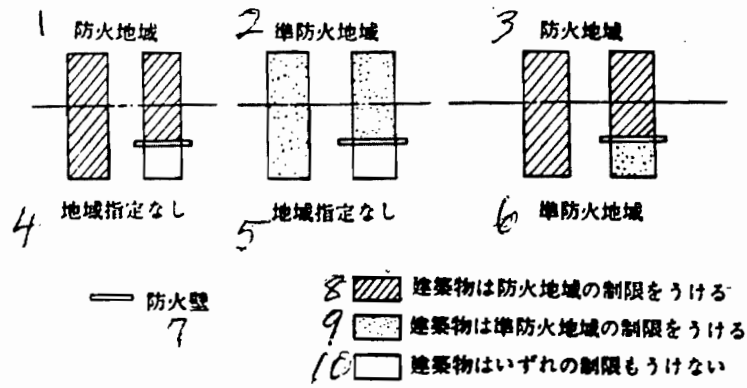

222

1 防火地域の場合	2 準防火地域の場合
① 増・改築部分の床面積の合計は 3 50㎡以下かつ、基準時[令137条] の延べ面積の合計以下	① 4 増・改築部分の床面積の合計は 50㎡以下
② 増・改築後の階数は2以下かつ、 延べ面積は500㎡以下	② 6 増・改築後の階数は2以下
7 ③ 増・改築部分の外壁及び軒裏は、耐火構造又は防火構造とする。	

set forth in part two of this section (Law 61, 62 part 1) the following list shall be used to determine the scope of such repaations. However if said structure is made of wood, then either a fire wall will be constructed around the property or the inside and eaves of the building will be redone with fire proof or fire re-istant materials (Order 137-7, 137-8).

Diagarm 222 The Scope for Remodeling or Expanding Already Existing Structures (Order 137-7, 137-8)

1 防火地域の場合	2 準防火地域の場合
① 増・改築部分の床面積の合計は50㎡以下かつ、基準時(令137条)の延べ面積の合計以下	① 増・改築部分の床面積の合計は50㎡以下
② 増・改築後の階数は2以下かつ、延べ面積は500㎡以下	② 増・改築後の階数は2以下
③ 増・改築部分の外壁及び軒裏は、耐火構造又は防火構造とする。	

SECTION VI

Seciton 6 District Planning

(1) What is a District Plan ?

The district plan and boreder road organizational paln are grouped together under the name "district plan", however each has its own unique thinking behind it. It was created as a part of the 1980 legal reorganization and is in fact part 7 of the Urban Planning Law. It is intended to supplement the previous years' macro approach to urban planning as well as the tendancey to view buildings and lots as the units for enacttment of laws for organizing the urban environment (the collective regulations of the Architectural Standards Law).

They are located in section 7 of the third chapter in the Architectural Standards Law, under the district planning heading #68-2, 68-5-4.

The contents of the various parts of the district plan that deal with the structure, facilities, and use of lots of buildings in either a district plan district or a border road reorganization

3. floor surface area of altered or added portion less than 50 sqm.
and less than extended floor surface area at standard time (Order 137)
4. floor surface area of altered or added area less than 50 sqm.
5. after additions or alterations building has 2 floors or less and
and extended surface area of less than 500 sqm.
6. after additions or alterations building has 2 or less stories
7. the eaves or outer walls of added or altered portion be made of
non-combustible or fire proof materials

Diagram 223 Outline of the District Planning System

1. subject of decision
2. city town village
3. decision procedure
4. depending on the procedures of the present Urban Plan
5. plan items
6. district or area
7. district plan district
8. district reorganization plan (considered as one section of the
district noted to the left)
9. contents
10. plan concerning the organization of the district
11. objective of the district plan
12. plan for the protection, development, and organization of
district plan districts
13. it is necessary to determine the following items.
14. scale and positioning of district facilities
15. restrictions on building use, maximum values for the buildings'

a district plan district or a border road reorganization district may be limited by restrictions determined at the municipal level (where it is in the interest of proper urban functions or insuring a wholesome urban environment) (Law 68-2).

In the case of laying roads in these districts, the position and scale of these roads will be determined by the authorizations of Law section 42 part 1 #5 (Law 68-3).

Also, under specified conditions, a Special Administrative Branch can authorize a proposed road plan for the location and scale of roads through the application of Law 44 (Restrictions on structures within roads) (Law 68-4).

2. (2) District plan : district reorganization plan

The system of district planning is taken from the West German model of urban planning. It was adapted from the District Details Plan section of the 1960 Federal Construction Law (Bundesbaugesetz). This law constrains the landowner and developer (this same law is also used as a basis for a Land Use Plan (Flachennutzungsplan) which constrains public bodies but not citizens) the plan covers almost all land with a development potential and it can be said that almost no wild development takes place.

Our nation's district planning system may be considered a start with its regulations and encouragement policies, however it is expected that with the addition of policies for directly aiding the development of planned districts the system will spread throughout the country in the future.

Diagram 223 Outline of the District Planning System

図表 223

決定主体		2 市 町 村	
決定手続		4 現行の都市計画決定の手続による(案作成時に土地所有者等の意見を求める)	
5 計 画 事 項	6 区域	7 地区計画区域	8 地区整備計画区域 (左の区域の一部でも可)
	9 内 容	11 地区の整備に関する方針 1. 地区計画の目標 2. 地区の整備、開発及び保全の方針地区整備計画区域 (一部について定める場合)	13 次の事項のうち必要なものを定める。 14. 地区施設の配置及び規模 21.5 建築物等の用途の制限、建築物の延べ面積の敷地面積に対する割合の最高限度、又は最低限度、建築物の建築面積の敷地面積に対する割合の最高限度、建築物の敷地面積、又は建築面積の最低限度、壁面の位置の制限、建築物等の高さの最高限度又は最低限度、その他建築物等に関する事項で政令で定めるもの 31.6 土地の利用の制限に関する事項で政令で定めるもの
17 制限等		18 な し	19.1 届出、勧告制度 (都法58-2条) (当該行為に着手する30日以前に届出、計画不適合について市町村長が設計の変更その他必要な措置を執ることを勧告) 20.2 開発許可の基準 (都法33条) 21.3 市町村の条例に基づく制限 (法68-2条) (建築物の敷地内は用途に関する事項) 22.4 道路位置指定に関する特例 (法68-3条) (道路の位置の指定は計画に即して行う) 23.5 予定道路の指定 (法68-4条)
24 整備主体		25 建築を行う者、開発行為を行う者又は市町村	
26 助成措置		27 1. 土地に関する権利の処分に関する斡旋その他の措置	
28 地区計画対象区域		29 1. 市街地開発事業等の事業が行われる又は行われた土地の区域 2. 今後市街化する土地の区域で不良な街区の環境が形成される恐れのある地域 3. 現に良好な居住環境が形成されている土地の区域	

extended floor surface area, maximum values for structure/lot ratio, surface area of lots, positions and restrictions on walls, maximum and minimum height restrictions, and other items determined by government order

16. restrictions on land use determined by government order
17. restrictions
18. none
19. system for reporting and warning (Urban Planning Law 58-2)
20. standards for approval of development (Urban Planning Law 33)
21. restrictions based on city, town and village ordinances (Law 68-2)
(items concerning the use of buildings on a given lot)
22. special examples of the authorization of the positioning of roads (Law 68-3) (the authorization for positioning roads comes from the Urban Planning Law)
23. authorization for reserved roads (Law 68-4)
24. subject of organization
25. the builder or city, town, village behind the development
26. assistance measures
27. mediation concerning the disposition of land rights
28. district that is the object of the district plan
29. districts in which urban renewal projects are taking place
30. districts in which there is the fear of damage to the environment resulting from further urbanization.
31. districts in which there is already a good residential environment

Diagram 223 (there is a mistake in the original numbering) Outline of the Framework for Border Roads Organization

1. authorization for border roads organization
2. governors authorization, approval of the Minister of Construction,

図表 223

決定主体	4 市 町 村	
決定手続	現行の都市計画決定の手続による(案作成時に土地所有者等の意見を求める)	
5 区域	6 7 地区計画区域	8 地区整備計画区域 (左の区域の一部でも可)
9 内容	10 地区の整備に関する方針 1.11 地区計画の目標 2.12 地区の整備、開発及び保全の方針地区整備計画区域 (一部について定める場合)	13 次の事項のうち必要なものを定める。 14.1 地区施設の配置及び規模 2.15 建築物等の用途の制限、建築物の延べ面積の敷地面積に対する割合の最高限度、又は最低限度、建築物の建築面積の敷地面積に対する割合の最高限度、建築物の敷地面積、又は建築面積の最低限度、壁面の位置の制限、建築物等の高さの最高限度又は最低限度、その他建築物等に関する事項で政令で定めるもの 3.16 土地の利用の制限に関する事項で政令で定めるもの
17 制限等	18 な し	19.1 届出、勧告制度 (都法58-2条) (当該行為に着手する30日以前に届出、計画不適合について市町村長が設計の変更その他必要な措置を執ることを勧告) 20.2 開発許可の基準 (都法33条) 21.3 市町村の条例に基づく制限 (法68-2条) (建築物の敷地内は用途に関する事項) 22.4 道路位置指定に関する特例 (法68-3条) (道路の位置の指定は計画に即して行う) 23.5 予定道路の指定 (法68-4条)
24 整備主体	25 建築を行う者、開発行為を行う者又は市町村	
26 助成措置	27 1. 土地に関する権利の処分に関する斡旋その他の措置	
28 地区計画対象区域	29 1. 市街地開発事業等の事業が行われる又は行われた土地の区域 2.30 今後市街化する土地の区域で不良な街区の環境が形成される恐れのある地域 3.31 現に良好な居住環境が形成されている土地の区域	

3. (3) Plan for the Reorganization of Border Roads

The Plan for Reorganization of Border Roads was born along with regulations concerning the Law Concerning Border Roads Running Off of Trunk Road Lines (1980 Law #34). The main goal of this is to designate certain trunk lines that carry the most traffic and are the noisiest around residential areas as "border roads" and thus provide for measures to reduce the noise level based on the Border Road Reorganization Plan's premise that the border road and its environment should be considered as a unified body. In this sort of area environmental reorganization both regulatory and assistance measures are employed, the regulatory measures being divided between

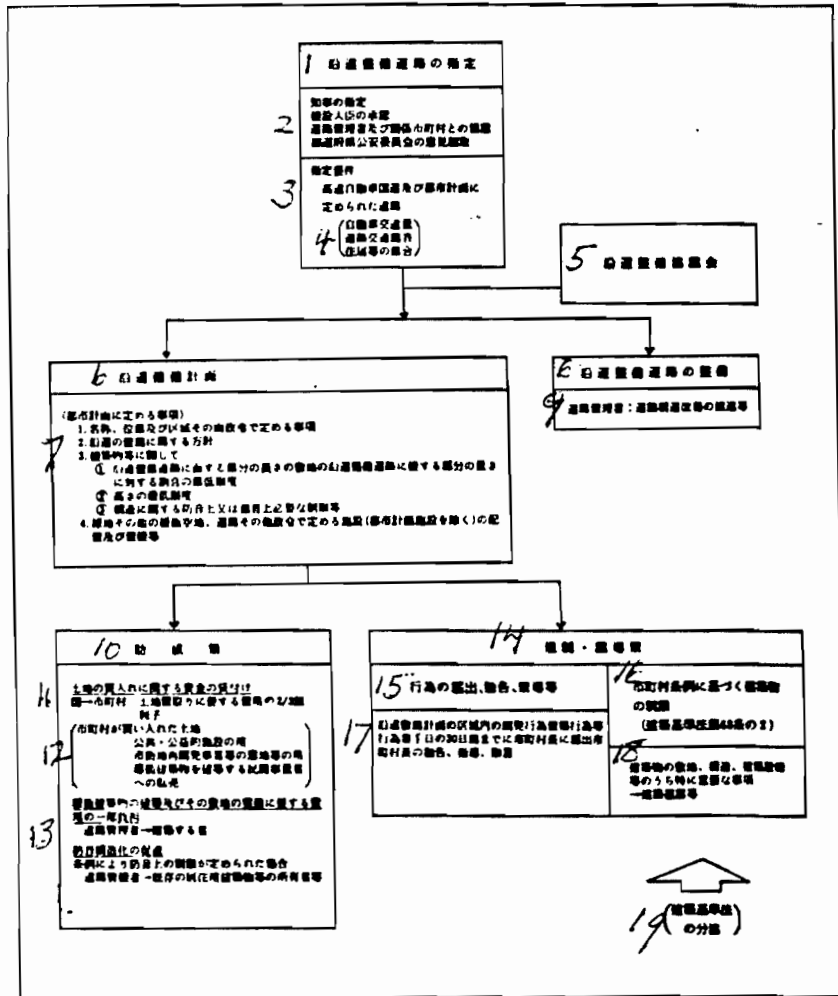

meeting of road manager and local public groups, hearing before the prefectural safety commission

3. conditions of authorization, highways or roads authorized by an urban plan

4. traffic load, traffic noise, concentration of homes

5. Conference on Border roads

6. border roads organization plan

7. items determined by the Urban Plan, name, position of road, plan for border road equipment, concerning buildings: length of lots which touch on border roads, maximum and minimum height restrictions, sound proofing construction; creation of "green belts" and other measures to insulate the urban environment from the border roads.

8. facilities for border road equipment roads

9. road managers, encouragement of road improvement

10. assistance policies

11. loans for purchase of land, local purchase from government 2/3 without interest.

12. local purchase of land, for public use or public facilities, for local redevelopment plans, or for resale to private individuals

13. the financial burden for protective buildings and their lot organization, road manager-- builder; encouragement of sound proof construction, when there are already regulations concerning soundproofing then the road manager must deal with the local landowners.

14. regulations and guidance policy

15. report, warning and leadership of activity

16. restrictions on buildings based on local ordinance (Architectural Standards Law 68-2)

17. all reports, warnings or guidance communication must be reported to the local government at least 30 days before the start of construction

the Urban Planning Law (Development Authorization System, etc.) and the Architectural Standards Law (Law chapter 3, part 7).

Diagram 223 Outline of the Framework for Border Road Reorganization

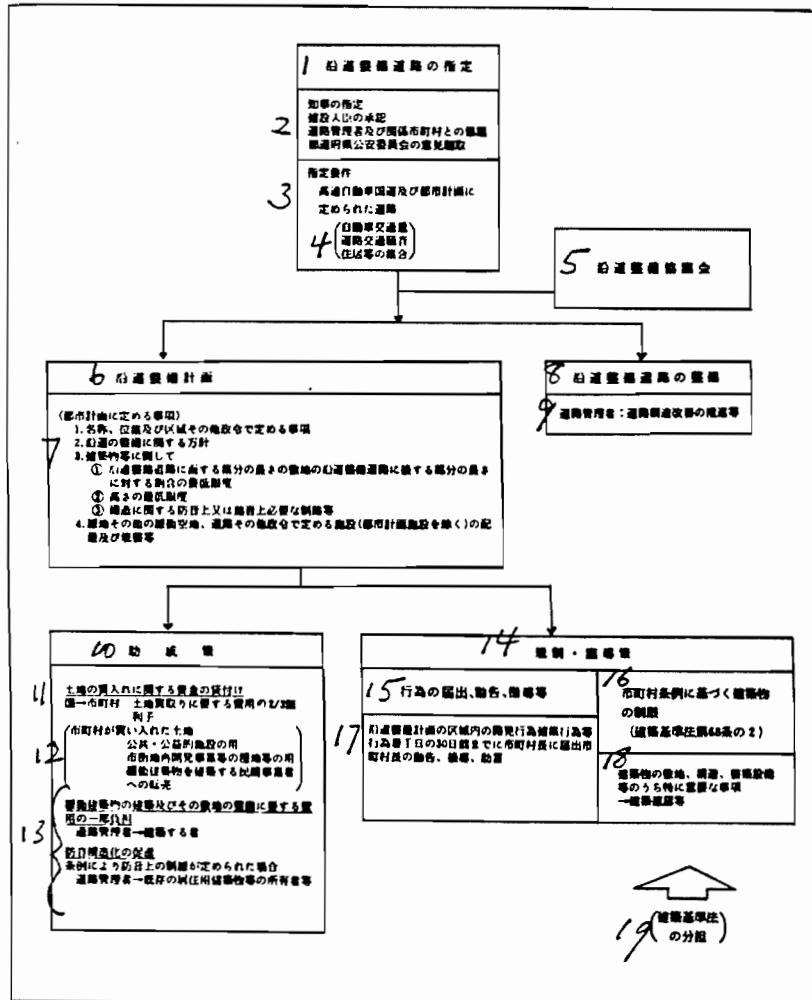

SECTION VII~~Part 7 Other~~

1. (1) Buildings in a Housing Project

The collective regulations in the Architectural Standards Law assume individual lots to be the standard unit when dealing with a change or unsettling of the conditions of land use in neighboring lots. And since in the event of general planning for a housing project the application of regulations with this kind of format creates irrational aspects, there is a special regulation for projects with a unified design that provides a relaxing of the normal lot to lot neighboring restrictions. (Law 86)

For example, in the case of the incline line restriction (excluding a neighboring lot incline line) (Law 56) the group of buildings in a project will be viewed as all being on one lot, the same applies for the road to lot restrictions--only the surrounding roads will be considered, and it is not necessary for each lot to face on a road (Law 43). The same applies to the capacity ratio (Law 52), structure/lot ratio (Law 53), setting back of outer wall in first class residential districts (Law 54), exceptions to the height restrictions in first class restricted residential districts (Law 55 part 2 # 3), shade related height requirements for middle and high buildings (Law 56-2), capacity, structure/lot ratio, and scale of surface area for high land use lots (Law 59 part 1), capacity ratio and relaxation of incline line height restrictions in lots with a large amount of open space (Law 59-2), capacity and height in specially designated districts (Law 60), and measures for preventing the spread of fire in semi fire fighting districts (Law 62, 64) in all these cases the groups individual lots may be considered to be one unified lot (Law 86 part 1). In addition, the Law 22 concerning

the prevention of the spread of fires which is part of regulations concerning neighborly relations from the second chapter of the Architectural Standards Law may be applied in the same manner.

Also, when there are many buildings in a given project, even if the entrances and exits are not covered by fire doors, the project may be approved if the structures have built according to fire resistant regulations (Law 86 part 3).

In addition, if the Urban Plan makes provisions for a housing project within a first class restricted residential district, then the structure/lot ratio and incline line height restrictions may be determined irrespective of the general standards (Law 86 part 4,5).

In any of the above cases where the buildings are designed, their positions determined by a unified plan, their construction is limited to what a Special Administrative Branch determines to be without obstacles to safety and hygiene.

2. (2) Architectural Agreement

As is indicated in the first clause of the law, the Architectural Standards Law's various regulations are intended in principle to protect the public welfare with the smallest amount of interference possible, and in the case of violations, enforce the law with both orders to rectify the problem and fines for punishment. It is hoped that with these measures it will be possible to achieve the minimum of these goals, however it is recognized that in order to provide the ideal environment there will be cases where the regulations of chapter three are insufficient.

It is here that, in order to protect a residential environment or to increase the convenience of a local shopping center, the residents (landowners, lessors and lessees) can, with a unanimous, voluntary consensus to cooperate, form an agreement with official binding

power; this is known as an Architectural Agreement (Law chapter 4 69--77).

The following are the contents of such agreements.

(1) Buildings' lots, (2) position, (3) structure, (4) use, (5) shape, (6) design, (7) facilities. For example, it is possible to form such an agreement when a portion of a residential area wishes to construct front-yards for all the houses, or standardize the height of all their fences, or to prevent uses of the land they consider detrimental to the residential environment (of course those prohibited by law would be banned anyway). These agreements are a restriction on the rights of individuals however, so to keep them from going to extremes they must be approved by a Special Administrative Branch, and before that approval can be granted they first must be aired at a local municipal meeting and the written documents of the agreement inspected (Law 70, 71, 72).

Also, in the event of the splitting up of a land development project, the residential developer, the regional residential public association, the Japan Residential Public Corporation, or even only a single owner, must all receive authorization for the breakup. In this case, whoever receives this divided land must honor the agreement.

3. (3) Scenic Districts

In order to preserve a scenic view of buildings in an urban area it is possible in the Urban Plan to designate that area a Scenic District (Urban Planning Law 8, 9).

Restrictions concerning the lot, structures and facilities needed to preserve a scenic view will be determined by the local public group (Law 68).

4. (4) Measures in the Event a Building's Lot Crosses the Borderline between Districts or Areas

If a building's lot should fall between two districts or areas that have different legal restrictions, then the entire lot will be considered to be covered by the laws of the area or district that contains over half of the surface area of the lot (Law 91).

However, this principle will be excepted in the following cases:

- (1) Law 22 part 1 's authorized district or area (Law 22)
- (2) capacity ratio restrictions (Law 52)
- (3) structure/lot ratio restrictions (Law53)
- (4) setting back of outer wall in first class restricted residential areas or districts (Law54)
- (5) height restriction in first class restricted residential areas or districts (Law55)
- (6) height restrictions (incline line restriction)(Law 56)
- (7) shade related height restrictions (Law56-2)
- (8)high level district (Law 58)
- (9) fire fighting, semi fire fightingh district or area (Law 61, 62)

For more information about each of these items please refer to their relevant sections. 図表 225

Diagarm 225

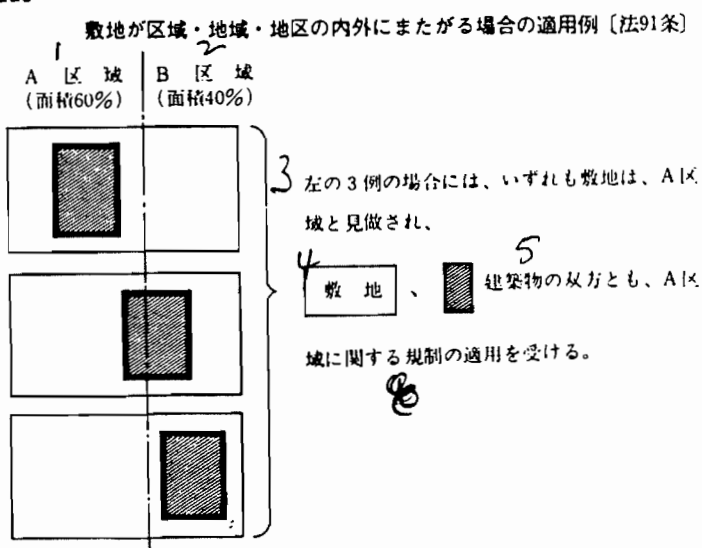

5. (5) Authorized Manufactures

Although manufactured facilities such as storage equipment or amusement facilities are not in themselves buildings, nonetheless their misuse can disrupt the environment and order of an urban area, so one section of manufactured articles (Law 88 part 2, Order 138 part 3) are restricted under Urban Plan regulations concerning land use and special land use districts and areas, Urban Plan policy towards locating industry, zoning changes, and the responsibility of builders for clearly showing seals of approval. (Law 88 part 2, Order 138 part 3, Order 144-2).

Diagram 226 Manufactured Articles Covered by the Collective Regulations (Law 88 part 2, Order 138 part 3, Order 144-2)

図表 226

集団規定が適用される指定工作物〔法88条2項、令138条3項・144-2条〕

工作物の用途	制限地域・区域
1. 法別表第2、3項3号13又は(13-2)の用途 13 原動機を使用する「鉱物、岩石、土砂、硫黄、金属、ガラス、れんが、陶磁器、骨又は貝がらの粉砕」 (13-2) 原動機(出力合計>2.5 kw)を使用する「レディミクストコンクリートの製造又はセメントの袋詰」	第1種住居専用地域 第2種住居専用地域 住居地域 近隣商業地域 商業地域
2. 法別表第2、4項1号2B (アスファルト、コールタール、木タール、石油蒸留産物又はその残りかすを原料とする製造)	①の地域及び準工業地域
3. 自動車車庫(築造面積>50㎡) (ただし、附属車庫を除く)	第1種住居専用地域 第2種住居専用地域 住居地域
4. 附属自動車車庫(築造面積>30㎡) ただし、同一敷地内の車庫以外の延べ面積× $\frac{1}{2}$ <300㎡のときは、その数値が制限面積。また同じく、<50㎡のときは、50㎡とする。	第1種住居専用地域
5. 附属自動車車庫(築造面積>150㎡) ただし、同一敷地内の車庫以外の延べ面積× $\frac{1}{2}$ <1500㎡のときは、その数値が制限面積。また、同じく<50㎡のときは50㎡とする。	第2種住居専用地域
6. 附属自動車車庫 (築造面積>同一敷地内の車庫以外の延べ面積× $\frac{1}{2}$) (ただし、 \leq 50㎡のものを除く)	住居地域
7. サイロ等の工作物(高さ>8m) (飼料、肥料、セメント等を貯蔵するもの)	第1種住居専用地域
8. 法88条1項(令138条2項)の観光用エレベーター、遊戯施設等の工作物(図表176参照)	第1種住居専用地域
9. 汚物処理場、ごみ焼却場その他の処理施設	都市計画区域全域

注1：土木事業その他一時的臨時のもの、適用除外。
注2：既存不適格建築物と同一敷地内の上表①②③④⑤⑥⑦⑧⑨についても適用除外。
注3：適用される規定の概要
法48条(用途地域制限)、法49条(特別用途地区制限)、法50条(条例による敷地、構造、設備制限)、法51条(特殊建築物の位置の許可)、法87条(用途変更)などのほか、建築確認申請手続(法6条)その他の手続規定。

18. items related to a buildings lot, structure, and facilities must pass construction approval

19. this burden borne by the Architectural Standards Law

Diagram 225 Example of the Application of Restrictions When the Lot Lies in Two Different Districts (Law 91)

1. A district (surface area 60%)
2. B district (surface area 40%)
3. In all of the examples to the left, the lot would be considered to be covered by the restrictions of district A.
4. lot
5. building would both be considered inside the bounds of district A.

Diagram 226 Manufactured Articles Covered under the Collective Regulations (Law88 part 2, Order 138 part 3, Order 144-2)

1. use of manufactured article
2. district or area restrictions
3. Law appendix chart #2, part 3 #13(13-2) used for metal, brick, sand, glass , procelain structures that use motors with an output greater that 2.5 kw.
4. first class restricted residential district, second class restricted residential district, residential district, neighborhood commercial district, commercial district
5. Law appendix chart #2, f part 1 #21 (asphalt, coal tar, pine tar or petroleum residues)
6. all of the above plus semi-industrial districts
7. automoblie garages (constructed area greater than 50sqm.) (excluding a garage attached to a home)
8. first class restricted residential districts, second class

敷地が区域・地域・地区の内外にまたがる場合の適用例〔法91条〕

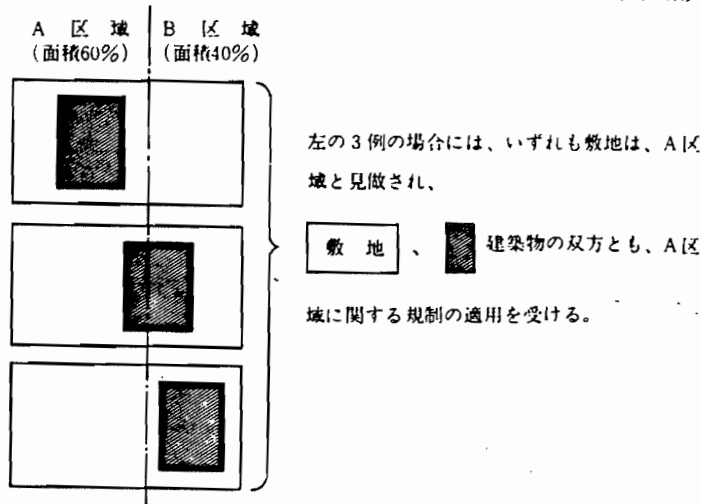

図表 226

集団規定が適用される指定工作物〔法88条2項、令138条3項・144-2条〕

工作物の用途	制限地域・区域
① 法別表第2、4項3号(13)又は(13-2)の用途 13 原動機を使用する「鉱物、岩石、土砂、硫黄、金属、ガラス、れんが、陶磁器、骨又は貝がらの粉砕」 (13-2) 原動機(出力合計>2.5kw)を使用する「レディミクストコンクリートの製造又はセメントの袋詰」	第1種住居専用地域 第2種住居専用地域 住居地域 近隣商業地域 商業地域
② 法別表第2、4項1号(1) (アスファルト、コールタール、木タール、石油蒸留産物又はその残りかすを原料とする製造)	①の地域及び準工業地域
③ 自動車車庫〔築造面積>50㎡〕 (ただし、附属車庫を除く。)	第1種住居専用地域 第2種住居専用地域 住居地域
④ 附属自動車車庫〔築造面積>300㎡〕 ただし、同一敷地内の車庫以外の延べ面積×½<300㎡のときは、その数値が制限面積。また同じく、<50㎡のときは、50㎡とする。	第1種住居専用地域
⑤ 附属自動車車庫〔築造面積>1500㎡〕 ただし、同一敷地内の車庫以外の延べ面積×½<1500㎡のときは、その数値が制限面積。また、同じく<50㎡のときは50㎡とする。	第2種住居専用地域
⑥ 附属自動車車庫 〔築造面積>同一敷地内の車庫以外の延べ面積×½〕 (ただし、≤50㎡のものを除く。)	住居地域
⑦ サイロ等の工作物(高さ>8m) (飼料、肥料、セメント等を貯蔵するもの)	第1種住居専用地域
⑧ 法88条1項(令138条2項)の観光用エレベーター、遊戯施設等の工作物(図表176参照)	第1種住居専用地域
⑨ 汚物処理場、ごみ焼却場その他の処理施設	都市計画区域全域

注1：土木事業その他一時的臨時的なものは、適用除外。
 注2：既存不適格建築物と同一敷地内の上表①②③④⑤⑥⑦⑧⑨についても適用除外。
 注3：適用される規定の概要
 法48条(用途地域制限)、法49条(特別用途地区制限)、法50条(条例による畜地、構造、設備制限)、法51条(特殊建築物の位置の許可)、法87条(用途変更)などのほか、建築確認申請手続(法6条)その他の手続規定。

restricted residential districts, residential districts

9. attached garages (surface area of home greater than 300sqm.)

However, when half of the area other than the garage on the lot is less than 300 sqm. then that amount will constitute the limit, otherwise if less than 50 sqm. then 50 sqm. will be the limit.

10. first class restricted residential district

11. attached garage (structure surface area greater than 1,500sqm.)

However, when half of the area other than the garage on the lot is less than 1,500 sqm. then that amount will be the limit. Also, if the area is less than 50 sqm. then 50 sqm. will be the limit.

13. second class restricted residential district

14. attached garage (when the structures' surface area is greater than half of the lot area excluding the garage, however, this excludes areas less than 50 sqm.)

15. residential districts

16. silos (less than 8 m. tall) (for storing feed, fertilizer, cement, etc.)

17. first class restricted residential districts

18. Tourist elevators and amusement facilities listed in Law 88 part 1 (Order 138 part 2) (see diagram 176)

19. sewage disposal plant, garbage incinerators, and other disposal facilities

20. entire area under the Urban Plan

21. Note 1 : this does not apply to temporary construction projects.

22. Note 2 : this does not apply to already existing buildings that do not meet the requirements, nor to structures on the same lot with the above (1), (2), (9).

23. Note 3 : outline of the regulations which apply

Law 48 (land use district restrictions), Law 49 (special land use district restrictions, Law50 (restrictions on lots, structures, and facilities), Law 51 (approval for the postion of special structures) Law 87 (change in land use), etc. and the construction approval application procedures (Law 6) and other procedural regulations.

Trans 363 from
J. J. Jones

CHAPTER IV

Necessary Procedures Prior to and During
the Existence of the Building

(p. 288 Text)

The Construction Standard Act requires that certain engineering standards (regulations concerning practical matters) be adhered to and that the goals of the regulations be met. In order to enhance efficiency, it also sets up a system of procedures for the submission of papers including the approval confirmation for. There is not only the Construction Standard Act but also the Architects Act, which defines the qualifications of engineers who engage in production, maintenance, and management. Besides these acts, in order to monitor national economic activities, papers concerning statistical data on construction must be submitted. Since various procedures are required at each stage of production, maintenance, and management, it is necessary for owners, construction managers, architects, construction superintendents, and workers to be thoroughly familiar with these regulations.

This chapter, section by section, will explain these acts and regulations. Figure 227 presents a summary of them.

Section 1. Prior to Construction

1. Blueprints and Architectural Regulations

In order to secure, maintain, and enhance the engineering standards of buildings, the Architect Act allows only certified architects (architects with certification of the first and

FIGURE 227

A Line of Procedures of Construction Activities

	Architects, Certified, Inspector	Owner	Building Director	Designated Administrative Agency	City Prefecture	Other Administrative Agencies
Blueprints	Blueprints	Building plans Approval Confirmation Request Notification of Approval Confirmation	Approval Confirmation	Permit Request The Board of Construction Examiners		Fire Department Chief Health Department Chief
Construction	Construction Superintendent Drawing up Safety Plan (*)	Construction Initiation Completion Certificate of Passing Inspection	Inspection	Submission of the Construction Safety Planning Form	Report of Construction Initiation	
Use of Building	Periodical Inspection (*)	Initiation of Use Maintenance Management		Periodical Report		Various Permits
Demolition and Loss		Demolition and loss		Mayor, Village Head	Report of Demolition Report of Loss	

Note (*): Certified inspector of special buildings, certified inspector of elevators, certified inspector of Building equipment. (Article 12, Section 2 of the Act. Department of Construction Issue, 1825, 198)

second classes) to draw up plans and to supervise constructions beyond a certain size and with certain structures (exclusive, restricted dealings: Architect Act, Article 3, Section 3-2).

Accordingly, in planning these buildings, a qualified architect must be secured first. However, even when planning buildings on a smaller scale, it is desirable to consult architects in both the planning and the inspecting stages of the building. Also under the Construction Standard Act, not only is approval confirmation withheld from buildings violating the Architect Act, but also the construction of such building is prohibited (subject to penalty). (Article 5-2 and Section 2 of Article 6 of the Act.)

Among architects, the title of first class architect is given to those who successfully pass the national examination and who register as such, and the title of second class architect is given to those who successfully pass the regional examination and who register as such.

2. Approval Confirmation Request

Besides the Construction Standard Act, there are other regulations governing the construction of buildings. These regulations are imposed for the sake of public benefits and public welfare. (Refer to Section 2 of Chapter 1). In essence, most of these regulations are in conflict with the direct interests of the owners. Therefore, it is necessary for administrative agencies to oversee the matter. Also because buildings are not purchased as finished products, it is necessary

FIGURE 228

Architects Exclusive, Restricted Dealings
(The Architect Act, Section 3-2 of Article 3.)

	Kinds and Structures of Buildings	Scale
<p>Planning and Inspecting the Construction, a right entitled only to those architects with a first class title.</p>	<p>Special Buildings Schools, hospitals, theater, movie theaters, stadiums, concert halls, meeting halls (except for those without an auditorium), and department stores.</p>	<p>When floor space exceeds 500m²</p>
	<p>Buildings using concrete with steel bars, steel frames, mason, bricks, concrete blocks, concrete without steel bars, and other similar materials</p>	<p>(1) When floor space exceeds 300m² (2) When height exceeds 13m (3) When eave exceeds 9m</p>
	<p>Large scale buildings</p>	<p>When floor space exceeds 1,000m² and the number of floor levels exceeds 2</p>
	<p>Buildings using concrete with steel bars, steel frames, mason, bricks, concrete blocks, concrete without steel bars, and other similar materials</p>	<p>When floor space exceeds 30m²</p>
<p>Planning and Inspecting the Construction, a right entitled only to those architects with a first, or a second class title</p>	<p>Large scale buildings</p>	<p>(1) When floor space exceed 100m², or the number of floor levels exceeds or are equal to 3</p>

FIGURE 229 (Cont.)

Region	Kinds of Buildings and other	Kinds of Construction	Comments
	<p>(3) Stone towers, decorative towers, and similar structures, when the height is greater than 4 meters.</p> <p>(4) Aboveground water tanks, silos, observation towers, when the height is greater than 8 meters.</p> <p>(5) Retaining walls, when the height is greater than 2 meters.</p> <p>(6) Elevators and escalators for sightseeing.</p> <p>(7) Watershoots, roller coasters, and similar structures.</p> <p>(8) Motor-propelled, rotating amusement equipment.</p>	Construction	
	<p>Installation of facilities and equipment [D]</p>	Installation	
Specified Zones	<p>Fixtures in the City Planning Zone or in certain zones for specific purposes (Refer to Figure 226) [E]</p>	Construction Production	
	<p>All buildings in the City Planning Zone (excepting those zones exempted by the Mayor) (Excluding A and B)</p>		
	<p>All buildings in the zones specified by the mayor or the prefect. (excluding A and B) [F]</p>	Construction	

for agencies to oversee for the purpose of protecting the buyers, the consumers, without sufficient engineering knowledge from the planners and managers while they are at work. Under the Construction Standard Act, the owner is obligated to submit an approval confirmation request form to the Building Director. The building Director is to examine it, checking whether the plan meets all regulations concerning construction (not only the Construction Standard Act, but also all laws governing the building site and the engineering standards for the structure and equipment). The Building Director is also to notify the owner of the result of his inspection within a given time period (in the case of a special buildings or a large scale building, 21 days; other buildings, 7 days). (Articles 6 and 7 of the Act).

- a) A range of buildings which require approval confirmation are listed in Figure 229.
- b) Blueprints have to be drawn up by an architect in the case of a building above a given scale. (Refer to 1.)
- c) Procedures and fees necessary to request approval confirmation are listed in Figure 231.
- d) A certain penalty will be imposed if construction starts prior to obtaining approval confirmation.

Note: Smaller scale buildings, which do not require the approval confirmation, must meet regulations concerning construction.

- e) Figure 232 is an example of an Approval Confirmation

Buildings Requiring Approval Confirmation (Section 87 and 88 of Article 6 of the Act.)

Region	Kinds of Buildings and other		Kinds of Construction	Comments
Nation wide	Special Buildings [A]	Buildings specified under the First (a) usage category of the Act (Refer to (1) to (6) of Figure 95)	When the total floor space to be used is greater than 100 m ²	<p>(1) There is no need to obtain approval confirmation in case of additions, alterations, or moving limited to the total floor space of 100m² or less, unless the zone is specified as the fire prevention or semi-fire prevention zones (Section 1 of Article 6 of the Act)</p> <p>(2) There is no need to obtain approval confirmation for temporary buildings for the construction of permanent building and for temporary shelters for disaster rescue operations and its restoration efforts. (Section 1 of Article 85 of the Act)</p>
	Large Buildings [B]	Wood frames	Three or more floors, or when the total floor space to be used is greater than 500m ²	
	Fixtures (refer to Figures 175 & 176) [C]	<p>(1) Chimneys, when the height is greater than 6 meters</p> <p>(2) Wood, steel and RC pillars, when the height is greater than 15 meters</p>	Two of more floors, or the total floor space to be used is greater than 200m ²	
		Other	Construction	

FIGURE 230

PROCEDURES FOR THE APPROVAL CONFIRMATION REQUEST AND REGULATIONS APPLICABLE TO A UNIT AND TO A GROUP

Zoné Classification Building Classification Regulation Applicable Section	All areas in Japan		
	Within the zones exempted from procedures by the mayor	Within the City Planning Zone	Outside the City Planning Zone
Unit Regulation [A]		Within the zones specified by the Mayor, requiring approval confirmation	
Group Regulation [A]			
Unit Regulation [B]			
Group Regulation [B]			
Unit Regulation (*1) [C]			
Group Regulation [C]			
Unit Regulation [D]			
Group Regulation (*2) [D]			
Unit Regulation [E], [F]			
Group Regulation [E], [F]			

Note 1: Other regulations concerning the building site, structure, and equipment are omitted. [A] to [F] in this figure correspond to [A] to [F] in Figure 229.

Note 2: Among [C] items, those fixtures which are within the City Planning Zone and are specified by Section 2 of Article 88 of the Act require approval confirmation, to which group regulations apply.

Note 3: *1 Only applicable regulations, *2 In case placement at already existing [A] and [B].

Unit or group regulations are applicable.

The procedure for approval confirmation is necessary.

FIGURE 229 (Cont.)

Region	Kinds of Buildings and other	Kinds of Construction	Comments
	<p>(3) Stone towers, decorative towers, and similar structures, when the height is greater than 4 meters.</p> <p>(4) Aboveground water tanks, silos, observation towers, when the height is greater than 8 meters.</p> <p>(5) Retaining walls, when the height is greater than 2 meters.</p> <p>(6) Elevators and escalators for sightseeing.</p> <p>(7) Watershoots, roller coasters, and similar structures.</p> <p>(8) Motor-propelled, rotating amusement equipment.</p>	Construction	
	<p>Installation of facilities and equipment [D]</p>	Installation	
	<p>(1) Elevators and escalators</p> <p>(2) Those specified by the administrative agency (except for septic tanks)</p>	Construction Production	
Specified Zones	<p>Fixtures in the City Planning Zone or in certain zones for specific purposes (Refer to Figure 226) [E]</p>	Construction	
	<p>All buildings in the City Planning Zone (excepting those zones exempted by the Mayor) (Excluding A and B)</p> <p>All buildings in the zones specified by the mayor or the prefect. (excluding A and B) [F]</p>		

FIGURE 231

(Article 10 and 11 of the Act)

Total Floor Space (See Footnote)	Handling Fee (in yen)
$\leq 30 \text{ m}^2$	3,000
$30 \text{ m}^2 < \leq 100 \text{ m}$	5,000
$100 \text{ m}^2 < \leq 200 \text{ m}^2$	6,000
$200 \text{ m}^2 < \leq 500 \text{ m}^2$	9,000
$500 \text{ m}^2 < \leq 2,000 \text{ m}^2$	21,000
$2,000 \text{ m}^2 < \leq 10,000 \text{ m}^2$	90,000
$10,000 \text{ m}^2 < \leq 50,000 \text{ m}^2$	150,000
$50,000 \text{ m}^2 <$	300,000
Building equipment and fixture, 1 item	5,000
Electric dumbwaiter, 1 item	2,500

Note: In case of moving, large scale repairs, remodeling, and change in usage, half of that floor space should be used for calculations for fees.

An Example of the Approval Confirmation Request Form
(Article 1 of the Regulation)

Form 1 Original Copy (B5)
Original

AN APPROVAL CONFIRMATION REQUEST FORM (BUILDINGS)

(Note): Before filling in this form, please read carefully the list of items at the bottom of the duplicate.

I hereby request the approval confirmation specified in Section 1 of Article 6 of the Construction Act. * Fee
The content of the description in this request form are nothing but the truth.

Date: (month) (day) (year) Seal

Name of person who is requesting the approval confirmation: Telephone Number: _____

1. Name and address of the owner: () class architect Registration #: _____

2. Certification of the representing agent: Name and address: _____
Architect Office: () class architectural Agency Registration #: _____ Tele: _____
() class architect Registration #: _____

3. Certification of the architect Name and address: _____
Architect Office: () class architectural Agency Registration #: _____ Tele: _____
() class architect Registration #: _____

4. Certification of the Construction Inspector Name and address: _____
Construction Office: () class construction office Registration #: _____ Tele: _____

5. Builder Builder Registration #: _____ Tele: _____

6. Location of Site a. Address of Site _____
b. Zoning _____
c. Fire Protection Zone Fire Protection Zone, Semi-fire Protection Zone, Non-designated zone _____

7. Main usage d. *Other areas, zones, and sections _____
8. Kind of Construction: New, Addition, Improvement, Moving, Change in usage, large scale Repair work, Large scale Remodeling *12. Proportion to site space _____

9. Site Area Area requesting Area not requesting Total _____

10. Building area _____

11. Total floor space () () () _____

13. Planned Date for Breaking Ground (month) (day) (year) _____

14. Planned Date for Completion (month) (day) (year) _____

15. Other Information _____

FIGURE 232 (Cont.)

16. A summary of the Building (Number: _____)			
a. Usage:	d. Roofs		
b. Category of Construction	e. Exterio Walls		
c. Structure	f. The underside of the Eaves		
Floor Category	floors	floors	Total
g. Floor area			
Part requesting approval			
Part not requesting approval			
Total			
h. Inner Diameter of Pillars	m. aximum Height		
i. Distance between beams	n. Maximum Height of the Eaves		
j. Distance between floors	o. Height of Floor in relation to the Ground		
k. Ceiling height of the Living Room	p. Kind of toilet	Flush Toilet	Traditional
l. Kind of Building equipment			
DO NOT WRITE IN THIS SPACE			
For record use by the Reception Office Only		Final Decision	The approval Confirmation number
(month) (day) (year)	the Fire Department Only		(month) (day) (year)
Number: _____			Number: _____
Received by: _____ (Seal)			Approved By _____ (Seal)

Request Form, which is defined under the procedure regulations of the Construction Standard Act. (Regulation in Section 1, Article 6.) (A request set consists of the blueprints and a summary of construction plans.)

3. Permit Request

The submission of the approval confirmation request form is sufficient for regular buildings. However, some matters which are prohibited under regulations of the Construction Standard Act can be permitted under certain circumstances. Procedures for these special provisions are made. That is, a matter granted by a special permit might adversely affect the people living in the surrounding areas and produce a complicated conflict of interest. Therefore, a designated administrative agency usually holds a public hearing by inviting people with opposing views and obtains approval from the Building Commission prior to issuing a permit.

Figure 233 presents items requiring permits and procedures.

4. Other

- a. Request for approval of new materials of construction grant a permit.
- b. Approval of the Fire Department Chief (Article 93 of the Act).

The Building Director is to obtain approval from the Fire Department Chief when he requests the approval confirmation, while the Designated Administrative Agency is to obtain approval from the Fire Department Chief when it issues a permit.

- c. The Development Permit and other. The development of more than one thousand square meters within the Urbanization Maintenance Zone

FIGURE 233
Special Permit Items and Procedures.

Special Permit Items	Articles	Procedures	Comments
Permit for building on a street	Article 44 of the Act	Approval from the Construction Review Board	Public roads for pedestrian,
Permit for pillars which support a walkway and whose heights are greater than those of the surrounding walls	Article 47 of the Act	Approval from the Construction Review Board	
Permit for exemption from prohibitions due to Zone specifications	Article 48 of the Act	Public hearings, Approval from the Construction Review Board	The exemption from prohibition of usage other than the specified usage in first category exclusive residential zones, second category exclusive residential zones, neighboring commercial zones, commercial zones, semi-commercial zones, industry zones.
Permit for the location of special building	Article 51	Meeting held by City Planning Commission	Sales markets, slaughter houses, cremation sites, waste treatment sites, dump sites.
Permit to use the planned road as the front road	Section 3 of Article 53 of the Act	Approval from the Construction Review Board	
Permit for exemption to the regulation concerning the proportion of the building site to the total site	Section 4 of Article 52 of the Act	Approval from the Construction Review Board	<ol style="list-style-type: none"> 1. Buildings containing many rooms of machinery 2. In cases where the site is surrounded by a large vacant area, i.e., a park.

FIGURE 233 (Cont.)

<p>Permit for exemption from the height restrictions within the first category exclusive residential zone</p>	<p>Clause 1 & 2 of Section 2 of the Article 55 of the Act</p>	<p>Approval from the Construction Review Board</p>	<p>In cases where the site is surrounded by a large vacant area i.e., a park and when it is judged that no damage will be done to the environment of the height restricted residential zone 2. Exceptional cases, i.e., a need for building a school.</p>
<p>Permit for exemption from height restrictions which were imposed to avoid the shadow effect.</p>	<p>Clause 1 of Section 2 of Article 55 of the Act</p>	<p>Approval from the Construction Review Board</p>	<p>In case when it is judged that there should be no damage on the residential environment to the location.</p>
<p>Permit for buildings with less than the minimum limit for the ratio of retaining walls space to the buildings in the highly used zone</p>	<p>Clause 3 of Section 1 of Article 59 of the Act</p>	<p>Approval from the Construction Review Board</p>	<p>In cases where it is judged to be necessary due to its specific usage and structure for the sake of public interests, i.e., schools and wholesale markets.</p>
<p>Permit for an exemption from the the slash line zone limit of a road within a high usage zone</p>	<p>Section 2 of Article 59 of the Act</p>	<p>Approval of the Construction Review Board</p>	<p>In the case of a usable, empty lot is available along the road within the site</p>
<p>Permit for an exemption from the building ratio within the high usage zone</p>	<p>Section 3 of Article 59</p>	<p>Approval of the Construction Review Board</p>	<p>(Refer to Article 52 of the Act)</p>
<p>Permit for an exemption from the limits for the ratio of the fence, the ratio for the building, and the height of the building with a large vacant site</p>	<p>Section 1 of Article 59-2 of the Act</p>	<p>Approval of the Construction Review Board</p>	<p>In cases where there is a vacant lot; the site scale is specified by law for that site; it is judged that there is no hazard for traffic safety, fire prevention, and sanitation; the fence ratio, the building ratio, and the height are judged to be adequate; and it is believed to enhance the city environment.</p>
<p>Permit for temporary buildings</p>	<p>Article 85 of the Act</p>		<p>Temporary buildings for disaster rescue efforts (with a duration of 2 years or less) trade fair buildings and similar structures (with a duration of 1 year or less) temporary stores or similar structures during construction.</p>

requires to obtain a separate permit for development from the Mayor, or the Prefect (Articles 3 and 7 of the Metropolitan Act).

Section 2. Breaking Ground

The breaking of the ground starts when the construction plan is approved on the basis of the blueprints and plans. It is essential that the actual construction follows the approved blueprints. Therefore, the construction of buildings beyond a certain scale must be inspected by an architect. (Refer to Clause 1, Section 1.)

1. Report on Building Construction

The owner of the future building has to submit, besides the approval confirmation request form, a report on building construction to the Mayor. See Figure 234. The purpose of this is to allow the government to know about the building activities. Therefore, the information will be forwarded from the Mayor to the Ministry of Construction and will be published in Construction Statistics. This report must be submitted when the floor space of the building exceeds ten square meters. You should be aware that even in some cases where approval confirmation is not necessary, this report must still be submitted. (Article 15 of the Act.)

2. Obligation to Display the Approval Confirmation

In the case of the construction of a building requiring the approval confirmation, a note must be displayed at the construction site, stating that the construction is legal and identifying the person who is in charge. Also, the blueprints which were submitted for the approval confirmation must always be kept at the construction site. The form of the

FIGURE 234

The Building Construction Report (Article 8 of the Regulation)

Form 9 (B5)

The Building Construction Report in accordance with Section 1 of Article 15 of the Construction Standard Act)

DO NOT WRITE IN THIS SPACE

*For record use by the Reception Office only

Approval Confirmation Number: _____

Date of Approval: _____ (month) _____ (day) _____ (year)

Site: _____ (month) _____ (day) _____ (year) (Seal) _____ telephone # _____

Telephone #: _____

Name and Address of the Building Construction Superintendent: _____

Architect or Representing Agency) _____

Owner (Circle the appropriate number) _____

1. Nation 2. City/Prefecture 3. Village/Town 4. Corporation 5. Non-corporation group 6. Individual

Construction Location _____

Construction Schedule _____

From: _____ (month) _____ (day) _____ (year) To: _____ (month) _____ (day) _____ (year)

Kind of Construction (Circle the appropriate number) _____

1. New Construction 2. Addition 3. Improvement 4. Moving

Major Usage of the Building _____

_____ (industrial) building (specify in detail the kind of business which will use the building, e.g. a lumber business, a confectionary)

Description of each building (Describe each separate building.)

a. Usage (Describe each building. If the building is to be used for more than three purposes, Circle Multiple Usage.)

b. Structure of Building Parts (Circle the appropriate number)

	Multiple 1.	Multiple 2.	Multiple 3.	Multiple
1. Wooden frame	1. Wooden frame	1. Wooden frame	1. Wooden frame	1. Wooden frame
2. Concrete with a steel frame and steel bars	2. Concrete with a steel frame and steel bars	2. Concrete with a steel frame and steel bars	2. Concrete with a steel frame and steel bars	2. Concrete with a steel frame and steel bars
3. Concrete with steel bars	3. Concrete with steel bars	3. Concrete with steel bars	3. Concrete with steel bars	3. Concrete with steel bars
4. Steel frame	4. Steel frame	4. Steel frame	4. Steel frame	4. Steel frame
5. Concrete blocks	5. Concrete blocks	5. Concrete blocks	5. Concrete blocks	5. Concrete blocks
6. Other	6. Other	6. Other	6. Other	6. Other
	m ²	m ²	m ²	m ²
	yen (in 10,000 yen) floors	yen (in 10,000 yen) floors	yen (in 10,000 yen) floors	yen (in 10,000 yen) floors
				m ²

c. Total Floor space _____

d. Projected cost of construction (including the cost of building equipment) _____

e. Number of floors _____

In the case of a new building, size of the site _____

FIGURE 234 (Cont.)

New Buildings (construction of new residential unit(s) or construction of new independent residential units with a livingroom, kitchen, and bathroom through addition and improvement)		Other (Construction of residential units through addition and improvement, yet the criteria given in the left column does not apply to your case)	
1. New Building	2. Addition	3. Improvement	4. Other
1. Private funds	2. Public funds	3. The Housing Loan Corporation	4. The Japan Housing Corporation
1. Traditional	2. Prefabricated	1. Traditional	2. Prefabricated
1. Owner's residence	2. Rental	3. Company Owned	4. Condo
1. Residence Only	2. Multi Unit	3. Other	
1. Single family	1. Single family	1. Single family	2. Apartment
floors	floors	floors	floors
m ²	m ²	m ²	m ²
Total floor space of residential construction			

If old existing buildings will be demolished in order to build the above mentioned building, and if you have not submitted a Building Demolition Report, please fill out the reverse side of this form. Also, read "The Instructions for Filling Out the Building Construction Report" before you complete this form.

(Reverse side of Form 9)

Please fill out this form if you plan to demolish an existing building in order to build new buildings.

1. The name and address of the Agency which will engage in the Demolition work:		Seal	Telephone #:
2. Major Usage:		(industrial) usage	
3. Reason for demolition:		1. Dangerous condition due to the aging and the decaying	
		2. Other	
4. Kind of Structure		1. Wooden	2. Other
5. Number of buildings to be demolished		Units	
6. Number of residential units to be demolished		m ²	
7. Total floor space of the Building		(in 10,000 yen)	
8. Estimated value of the building			

- (Note)
1. Each question concerns the building(s) which are to be demolished.
 2. To question #2, state the general usage of the building(s).
 3. In Questions # 3 and 4, circle the number which applies to your case.

THE INSTRUCTIONS FOR FILLING OUT THE BUILDING CONSTRUCTION REPORT

1. Item 4, kind of construction If both additions and improvements are to take place, provide the information on the basis of the larger building.
2. Item 5, major usage of the building If there is an existing building, provide information concerning the general usage of the combination of the existing and the new building. For example, if an auto parts manufacturing company is to build a building for automobile bearings and another building for an engineering office, it would state the major usage as the manufacturing of automobile parts.
3. Item 6, a. Usage Describe the usage of each building separately. For example, as illustrated above for item 5: (1) Bearing factory, (2) Engineering Office. If one building will have two or more usages (including the usage of existing units), provide the information based on the units which will occupy the largest amount of floor space.
4. Item 8, a. the construction of new residential units and others 1. New residential units: The construction of new residential units includes additions which are joined to existing units, if the new units are to be used independently as a residential unit with a livingroom, a kitchen, and a bathroom. Other: If there is an existing building on the site, and the new building includes a livingroom of 50 square meters, the new unit cannot be used independently as a residential unit.
5. Item 8, b. Construction funds 1. Private funds: he funds are provided by private organizations, or citizens, and are not subsidized by national or local public organizations.
6. Item 8, c. Construction method 1. The traditional method refers to methods other than the prefabricated methods. 2. The prefabricated method refers to the method of manufacturing major structural parts, including walls, pillars, floors, beams, roofs, and stairs at the factory and putting these parts

7. Item 8, e. kind of residence.....
these parts together at the construction site.
Other refers mainly to those units which are to be attached to a factory, a school building, a hotel, motel, or inn, a lodging house, a public bath house, or a temple or shrine.

8. Item 8, f. the number of units and
g, the total residential construction
floor space
In the case of the construction of a building which will be composed of units to be used for more than two usages, provide the number of units and the total floor space for each usage.

note is shown in Figure 235. (Article 89 of the Act)

3. Hazard Prevention at the Construction Site

(Omitted) (Refer to 3 of Section 6 in Chapter 2)

4. Limiting Usage of Special Buildings During Construction

To use a part of a building while additions, improvements, or changes are being made might create danger in the terms of safety, fire prevention, and evacuation, creating a serious disaster. Therefore, a Designated Administrative Agency can order that the usage be limited during construction (new buildings, additions, improvements, and moving), repair work, remodeling, and demolition. This is done particularly in cases involving special buildings and large scale buildings (Articles 90,91, and 92 of the Act).

5. The Planning and Submitting of a Description of the Safety Measures to be Taken During Construction

The owner is required to draw up a plan dealing with measures for safety, fire prevention, and evacuation, and to submit the plan to the Designated Administrative Agency since, from the standpoint of fire prevention, it is dangerous to use the building listed in Figure 236 during their construction: theaters, movie theaters, hospitals, hotels, department stores, shopping centers, cabarets, other buildings with similar usage (listed in Sections 1,2,and 3 of the Act), and underground buildings.

The construction of evacuation facilities and equipment refers to the construction of those facilities and equipment listed in Figure 237. Excluded from the list are those minor jobs such as painting the rails of a balcony, replacing glass windows of entrance and exit doors, replacing the

FIGURE 235

The Notice Posted at the Construction Site
(Regulation 11)

35 cm or more

Approval Confirmation Granted in Accordance with the Construction Standard Act	
Date and Number of Approval Confirmation	
Name of the Building Director	
Name of the Owner of the Building	
Name of the Planner	
Name of the Construction Contractor	
Name of the Construction Superintendent	

25 cm or more

FIGURE 236

Buildings for which the owner must submit a description of the safety measures to be taken during construction (Article 147-2 of the Act)

Usage and other	Scale and size
1. Department store, shopping centers, and stores (excluding those with a floor space of 100 ² or less).	A total floor space of more than 1,500 m ² , when the areas of the pertinent usage parts on the 3rd and higher floors and on the underground levels are added together. A total floor space of more than 1,500 m ² , when the areas of the pertinent usage parts on the 5th and higher floors and on the underground levels are added together.
2. Hospitals, clinics with inpatient facilities, and children's welfare institutes (Section 1, Article 19 of the Act. Refer to Figure 95)	A total floor space of more than 1,500 m ² , when the areas of the pertinent usage parts on the 5th and higher floors and on the underground levels are added together.
3. Theaters, movie theaters, performance centers, stadiums, civic auditoriums, and meeting halls. Hotels, motels, and Japanese inns Cabarets, coffee shops, night clubs, bars, dance halls arcades, public bath houses, lounges, Ryoriya (a type of Japanese fashionable restaurant) 1. and 2 of the above stated	A total floor space of more than 1,500 m ² , when the areas of the pertinent usage parts on the 5th and higher floors and on the underground levels are added together.
4. New underground buildings	A total livingroom floor space of more than 1,500 m ² .

Note: The kinds of construction included here refer to the construction of new buildings and the construction of facilities and equipments for evacuation purposes.

The Range of Evacuation Facilities

- | | |
|------------------------------------------------------------------------------------------------------------------------------------------------------------------------------------------------------------------------------------------------------------------------------------------------|-----------------------------------------------------------------------------------------------------------------------------------------------------------------------------------------------------------------------------------------------------------------------------|
| <p>1. Entrance and exits doorways and pathways, for example, those in halls.</p> | <p>Hallways between the livingrooms and the uninterrupted stairways (stairways extending from the top floor to the evacuation floor) (Articles 120 and 121 of the Act)</p> <p>Hallways between the livingrooms and the uninterrupted stairways on the evacuation floor.</p> |
| <p>2. Exits leading from audience seats (Article 118 of the Act), uninterrupted stairways (Article 120 and 121 of the Act), balconies, exterior stairways effective for evacuation (Notes to Section 3 of Article 121 of the Act), and rooftop halls (Section 2 of Article 126 of the Act)</p> | <p>(Article 120 and 121 of the Act), balconies, and rooftop halls (Section 2 of Article 126 of the Act)</p> |
| <p>3. Underground pathways connecting units of an underground city, and the entrance and exit doors of the city. (Section 4, Article 128-3 of the Act)</p> | <p>(Section 4, Article 128-3 of the Act)</p> |
| <p>4. Automatic sprinkler systems, water jet, mist fire extinguishers, and foam fire extinguishers.</p> | <p>(Section 1 of Article 126-2 of the Act)</p> |
| <p>5. Smoke elimination equipment (Section 1 of Article 126-2 of the Act).</p> | <p>(Section 1 of Article 126-2 of the Act)</p> |
| <p>6. Lighting apparatus for use in emergencies (Article 126-4 of the Act).</p> | <p>(Article 126-4 of the Act)</p> |
| <p>7. Elevators for use in emergencies (Article 129-13-3 of the Act).</p> | <p>(Article 129-13-3 of the Act)</p> |
| <p>8. Fire prevention Zone (Article 112 and Section 2, Or 3 of Article 128-3 where Article 112 and Section 5 of Article 128-3 are applicable)</p> | <p>(Article 112 and Section 2, Or 3 of Article 128-3 where Article 112 and Section 5 of Article 128-3 are applicable)</p> |

Note: Those equipment and facilities are not to be treated as evacuation equipments and facilities, unless the building is required to meet the standards.

1. Article 112 of the Act (fire prevention zone)
2. Section 2, Chapter 5 of the Act (hallways, emergency stairways, and entrance and exit doors)
3. Section 3, Chapter 5 of the Act (smoke elimination facilities)
4. Section 4, Chapter 5 of the Act (lighting apparatus for use in emergencies).
5. Article 128-3 of the Act (underground pathways in emergencies).
6. Article 129-13-3 of the Act (the installation and structure of the elevators for use in emergencies)
7. Article 12 of the enforcement requirement outlined in the Fire Prevention Act (the standards concerning sprinkler systems), Article 13 (flammable objects requiring the installation of water jet and mist fire extinguishers) and Article 15 (standards concerning foam extinguishers).

FIGURE 238

The Report of Planned Safety Measures
(Article 11-2 of the Regulation)

Form 12 (B5)

The Report of Planned safety measures in accordance with Section 3 of Article 90 of the Construction Standard Act including cases where Section 1 of Article 87-2 are applicable)

To: The Designated Administrative Agency

Date: (month) (day) (year) (Seal)
Name of the person who submitted this form: Phone #:

1. The Name and Address of the Building Director:	class architect Registered Number
2. The Name and Address of the Qualified Representative	class architect Office Registration Number
3. A summary description of the building	Location
	Name Region
	Usage
	Structure Number of floors m ² Floor space m ²
	Site space m ² Building space m ²
4. Planned date for starting construction	
5. Planned date for completing construction	
6. Period of usage	
7. Number and date of the approval confirmation	
8. Number and date of the approval for temporary use	
9. Comments	

* For use by the Reception Office only
Date: (month) (day) (Year)
Number
Received by: (Seal)

(Note): * Do not fill in this box.

Second line: If the representative belongs to an architectural agency, provide the name and address of that agency.

Seventh line: Fill in the seventh line in case the approval confirmation is received.

Eighth line: Fill in the eighth line in case a temporary use permit is received.

Ninth line: Give the name and address of the person who drew up the plan of safety measures. State whether he has qualifications in construction. If so, state what kind of qualifications. Give the name and address of the construction company.

colored sheet of the lighting apparatus for emergency use and other jobs which do not interfere with the maintenance of the evacuation facilities.

Section 3. The Completion of the Construction and
the Initiation of the Building's Use

Once the construction has been completed and has passed the inspection determining whether the building satisfies the standard determined by construction related regulations and Acts, the building can be used.

1. **The Report of Completed Construction:** A report of completed construction must be submitted to the Building Director by the owner within four days of completion. A report form is presented in Figure 239 (Article 7 of the Act).
2. **The certificate of Passing the Inspection and the Limits on the usages of Special buildings:** Within seven days after receiving the report of completed construction, the Building Director must inspect the building and issue the certificate of passing the inspection if the building complies with all building related regulations and acts. Also, the buildings specified in clauses one, two, and three of Section one of Article six of the Act (refer to (A), (B), and (C), of Figure 229) cannot be used before obtaining the certificate of passing inspection (Article 7 of the Act). The same applies to additions, improvement, moving, large scale remodeling of the buildings specified in Clauses one, two, and three of Section one of Article six. This includes the construction of evacuation facilities and equipment (refer to subdivision five of the previous section), but excludes those buildings which are non-multi unit residential quarters and those buildings which do not have living rooms.

However, use of the building is permitted if the Designated Administrative Agency (that is, the Building Director, after the report of completed

FIGURE 239

An Example of a Report of Completed Construction
(Article 4 of the Regulation)

A Report of Completed Construction in accordance with requirement set by Section 1 of Article 7 of the Construction Standard Act.

To: Building Director

* For use by the Reception Desk only		
Date:	(month) (day) (year)	
Number:		

The Name and Address of the Owner of the Contractor: _____
Date _____ (Seal)

1. Date of completion	
2. Approval confirmation number	
3. Date of approval confirmation	
4. Construction site or Building Site	
5. The Name and Address of the Builder	
6. The Name and Address of the Construction Superintendent	The Builder's Registration Number: _____
7. Comments:	The Registration Number: _____

(Note): * Do not fill in this box.

construction is submitted) has issued approval for temporary usage, or if seven days have passed since the submission of the report of completed construction.

Section 4. The Maintenance and Management of Buildings

Once the building has been completed and is in use, the maintenance and management leaves the hand of the Building Director and moves to the hands of the actual users, that is, the owner, the manager, and the occupants.

However, the maintenance and management of the building is not limited to the maintenance of the engineering aspects of the upkeep. The condition of the building should be maintained so that it continues to meet construction related laws and regulations (Article 8 of the Act). A breach of obligations as maintenance manager may result in the production of a condition which violates the Construction Standard Act. Thus, the maintenance manager may become subject to penalty under Article 9 of the Act.

Also, if the condition violates other regulations as well, disciplinary actions both administrative and legal, will be taken, as specified under each law and regulation which is violated.

The author describes below the procedures for additions, repairs, remodeling, and changes in usage and the procedure for periodical inspections.

1. Additions, alterations, moving, repairs, and remodeling:
 - a. All additions alterations, moving, repairs, and remodeling of buildings which require approval confirmation must obtain that approval confirmation.
 - b. Large scale repairs and remodeling of the special buildings listed in categories (A) and (B) in Figure 229, require the approval confirmation.

This applies equally to those buildings constructed before the Act was enacted.

2. Installation of equipment: Approval confirmation is required (Article 87-2 of the Act and Article 146 of the Regulation) in the buildings specified in Clauses 1, 2, and 3 of Section 1, Article 6 of the Act, when the installation of elevators, escalators, and other building features specified by the Designated Administrative Agency occurs (Section 2 of Article 12 of the Act).

a. In case a building, through change in usage becomes one of the special buildings (a category (A) building with a total floor space greater than a hundred square meters), it must obtain approval confirmation even though no construction is involved.

However, it is not required to obtain approval confirmation if the change of usage occurs within a "similar usage" category (Article 137-9-2 of the Regulation).

b. In the case of a change in usage in a building which requires a special permit, the approval confirmation must be obtained, as in the case of a new construction.

3. Change in usage:

4. Periodical inspections and reports (Section 1 and 2 of Article 12 of the Act, Article 5 and 6 of the Rules, Notices of the Minister of Construction of 1970): In order to confirm the safety and fire prevention capacities of a building, it is necessary that its condition be checked regularly. The frequency of these inspection depends upon the usage and the scale of the building. Therefore, the Designated Administrative Agency identifies certain kinds of buildings and requests that the owners and the maintenance managers send periodocal reports.

Since the examination and inspection require specific professional engineering ability, they are conducted by professional, certified examiners and inspectors. When the owner or the manager fails to send a report, a

penalty will be imposed.

A list of buildings which must report periodically is shown in Figure 243.

Section 5. A Report on the Demolition of the Building

Once the building ceases its function and is to be demolished, those who will engage in the demolition are required to submit a Building Demolition Form to the Mayor, or Prefect. This report, like those dealing with the construction of new buildings, will be given to the Ministry of the Construction by the Mayor, or the Prefect. It will be used as statistical data and as an index to monitor construction activities.

Also, if the building is destroyed or damaged through an act of God, the report will be sent by the Mayor, or Prefect to the Ministry of Construction and will be compiled as statistical data.

Figure 244 presents the form of a Report on the Demolition of a Building (Article 15 of the Act).

Section 6. Temporary Buildings

In the case of some disasters within city limits, the Designated Administrative Agency is authorized to limit or to prohibit construction within the disaster zone for up to 30 days after the disaster, if the Agency judges it to be necessary for the purpose of city planning and zoning. The purpose of this is to prevent the unorderly construction of many buildings after the disaster which might cause future problems in city planning and zoning (Article 48 of the Act).

In the case of temporary emergency buildings to accommodate to needs after the disaster, the restrictions imposed by the Construction Standard Act will be amended to be more lenient. These cases can be categorized into

The Request Form for Approval of Temporary Usage
(Article 4-2 of the Regulation)

<p>The original copy of Form 2 of Number 7 (B5)</p> <p>A Request Form for Approval of Temporary Usage</p>	
<p>Original</p> <p>(Note): Before filling in this form, please read carefully the instructions given at the bottom of the duplicate copy. The undersigned hereby requests approval for temporary usage as required under Clause 1, Section 1, Article 7-2 of the Act (including cases where section 1 of Article 87-2, or Section 1 or 2 of Article 88 of the Act is applicable).</p>	
<p>To: The Designate Administrative Agency</p>	<p>Date: _____ (month) _____ (day) _____ (year) (Seal)</p> <p>The name of the person requesting approval: _____</p>
<p>1. Name and address of the owner, or the construction Planner, or the Construction agency</p>	<p>_____ Telephone #: _____</p>
<p>2. Name and address of the qualified representative Name of the Architectural Office</p>	<p>_____ class architect Registration Number _____</p> <p>_____ Class architectural Agency Registration Number: _____ Telephone #: _____</p>
<p>3. The number and the date of approval confirmation</p>	
<p>4. The address of the building site</p>	
<p>5. The building and the fixtures to be constructed.</p>	
<p>6. The usage of the temporary buildings</p>	
<p>7. The planned date for the initiation of construction</p>	
<p>8. The planned date for the completion of construction</p>	
<p>9. The duration of temporary usage</p>	
<p>10. Reasons for the request</p>	
<p>11. Comments</p>	
<p>* Inspector (Title and Name) Seal</p>	
<p>For use by the Reception Office only</p>	<p>* Building Director (Name) Seal</p>
<p>Date: _____ (month) _____ (day) _____ (year)</p>	<p>* Decision _____ * Approval Number _____ * Special notes</p>
<p>Number: _____</p>	<p>Date: _____ (mo) _____ (day) _____ (yr)</p>
<p>Received by: _____ (Seal)</p>	<p>Number: _____</p>
	<p>Approved by: _____ (Seal)</p>
<p>* Conitions</p>	

FIGURE 241

The Request Form for Approval of Temporary Usage
(Article 4-2 of the Regulation)

The original copy of Form 3 of Number 7 (B5)

Original

A Request Form for Approval of Temporary Usage

(Note): Before filling in this form, please read carefully the instructions given at the bottom of the duplicate copy.
The undersigned hereby requests approval for temporary usage as required under Clause 1, Section 1, Article 7-2 of the Act (including cases where section 1 of Article 87-2, or Section 1 or 2 of Article 88 of the Act is applicable).

To: The Designate Administrative Agency Date: _____ (month) _____ (day) _____ (year) (Seal)
The name of the person requesting approval;

1. Name and address of the owner, or the construction Planner, or the Construction agency Telephone #:
_____ class architect Registration Number
_____ Class architectural Agency Registration Number: _____
_____ Telephone #: _____

2. Name and address of the qualified representative Name of the Architectural Office

3. The number and the date of approval confirmation

4. The address of the building site

5. The building and the fixtures to be constructed.

6. The usage of the temporary buildings

7. The duration of temporary usage

8. Reasons for the request

9. Comments

* Building Director (Name) Seal		* Inspector (Title and Name) Seal	
* Special note:		* Decision	
Date: _____ (month) _____ (day) _____ (year)	Number: _____	* Approval Number	* Special notes
Received by: _____ (Seal)		Date: _____ (mo) _____ (day) _____ (yr)	Number: _____
		Approved by: _____ (Seal)	

* Conditions

FIGURE 242

The Certificate of Passing the Inspection
(Article 4 of the Regulation)

The Certificate of Passing Inspection Required by Section 3 of Article 7 of the Building Standard Act.

Number: _____
Date: _____ (month) _____ (day) _____ (year)
(Seal)

Building Director (Name):

This certificate is issued upon passing the inspection and states that the construction of the building described below has met the laws regarding the building site, the structure, and the building features. It has met all specifications based upon laws and upon regulations defined under Article 88 of the Construction Standard Act, and specifications based upon the Act, but not mentioned specifically in the Act.

1. Number of the approval confirmation	
2. Date of the approval confirmation	
3. Construction site or building location	
4. A summary of the buildings, the building features, or the parts of the buildings which were inspected.	
5. The name and address of the owner of the Builder	
6. Date of the Inspection	
7. The name and the title of the Inspector	(Seal)

(Note): Please keep this certificate safe, along with the approval confirmation notice.

FIGURE 243

Buildings Requiring a Periodical Report

<p>Buildings and others</p>	<p>Certified examiners and inspectors defined by the Minister of Construction in accordance with Section 1 and 2 of Article 12.</p>
<p>a. Special buildings to be used for the purposes specified in line (a) of the 1st list of the Act. (Refer to (1) and (2) of FIGURE 95)</p>	<p>Certified special building examiners and inspectors. 1. Those who passed the Building Director Examination 2. Those who completed seminar courses certified by the Minister of Construction. (Issue 797 Notice of the Minister of Construction, 1970)</p>
<p>b. Elevators</p>	<p>Certified elevator examiners and inspectors 1. Those who passed the Building Director Examination. 2. Those who completed seminar course certified by the Minister of Construction. (Issue 798 Notice of the Minister of Construction, 1970)</p>
<p>c. Building facilities and equipment of buildings specified in line (a)</p>	<p>Certified facilities and equipment examiners and inspectors. 1. Those who passed the Building Director Examination. 2. Those who completed seminar courses certified by the Minister of Construction. (Issue 799 Notice of the Minister of Construction, 1970)</p>

FIGURE 244

A Report on the Demolition of a Building
(Article 8 of the Regulation)

Form 10 (the size of a postcard)

In Accordance with Section 1 of Article 15 of the
Construction Standard Act.

A Report on the Demolition of a Building

* For use by the Reception Desk Only

Date: _____ (month) _____ (day) _____ (Year)

To: The Mayor _____

The name of the person who will engage in the demolition: _____ (Seal)

Telephone #: _____

1. Demolition location	_____ (month) _____ (day) _____ (year)
2. Planned date for demolition	_____ (year)
3. Major usage	_____
4. Reason for demolition	1) Dangerously decayed (2) Other
5. Kind of Structure	1) Wood frame (2) Other
6. Number of Buildings	_____
7. Number of units of residence	_____ Units
8. The total floor space of the building	_____ m ²
9. Estimated value of the building	_____ yen (in 10,000 yen)

(Note): (1) * Do not fill in this box.

(2) For each item, describe the building to be demolished.

(3) For item number 3, state the general usage of the total building on the site.

(4) For items number 4 and 5, circle the number which applies to your case.

FIGURE 244

A Report on the Demolition of a Building
(Article 8 of the Regulation)

Form 10 (the size of a postcard)

In Accordance with Section 1 of Article 15 of the Construction Standard Act.

A Report on the Demolition of a Building

* For use by the Reception Desk (Only)

Date: ____ (month) ____ (day) ____ (Year)

To: The Mayor _____

The name of the person who will engage in the demolition: _____ (Seal)

Telephone #: _____

1. Demolition location	_____ (month) ____ (day) ____ (year)
2. Planned date for demolition	_____ (year)
3. Major usage	_____ (2) Other
4. Reason for demolition	(1) Dangerously decayed
5. Kind of Structure	(1) Wood frame (2) Other
6. Number of Buildings	_____ Units
7. Number of units of residence	_____ m ²
8. The total floor space of the building	_____ yen (in 10,000 yen)
9. Estimated value of the building	_____

- (Note): (1) * Do not fill in this box.
 (2) For each item, describe the building to be demolished.
 (3) For item number 3, state the general usage of the total building on the site.
 (4) For items number 4 and 5, circle the number which applies to your case.

two groups listed below as 1 and 2 (Article 85 of the Act and Section 1 of Article 147 of the Regulation).

1. Those buildings for which the Construction Standard Act, the Regulation, and all rules in accordance with the Act and the Regulation will be lifted (Section one of Article 85 of the Act).

a. Repairs to buildings in the area of the disaster or its neighboring areas, which are determined by the Designated Administrative Agency, if the repair starts within a month after the disaster.

b. Construction of buildings within the area specified above in a., if the construction starts within a month after the disaster and if it falls in either of the following categories.

1. The construction of buildings by the National Government, local public sector, or the Japanese Red Cross for the purpose of aiding or rescuing disaster victims.

2. The construction of houses to be used by disaster victims if the total floor space is less than or equal to 30 square meters.

2. Those buildings to which only some of the construction related regulations will apply, especially those regulations dealing with the strength of the structure and the fire prevention facilities. In this category are those buildings which it is necessary to rebuild for the public wellbeing, such as train stations and Post offices (Section 2 of Article 85 of the Act).

The above mentioned temporary emergency buildings can be used for three months, or with permission for the Designated Administrative Agency, they can be used for up to two years (Section 3 of Article 85 of the Act).

3. Only some of the construction related regulations, mostly those dealing with the structural strength and fire prevention, apply to temporary buildings on the construction site of a permanent building. Included as temporary buildings are the office building, barracks, and construction material shed. They can be used until the construction of the permanent

FIGURE 245

The Articles Which Exempt Temporary Buildings from the Regulations, if Those Buildings are for Emergency Use or for Use during the Construction of a Permanent Building (Article 85 of the Act, and Section 1 of Article 147 of the Act)

Categories	Articles Exempting Application of the Regulations
<p>Section 1 of Article 85 Temporary emergency Buildings in case of Severe disaster. (Refer to (1) of the explanations given in the text.)</p>	<p style="text-align: center;">EXEMPTION FROM ALL RULES AND REGULATIONS</p>
<p>Section 2 of Article 85 Temporary emergency buildings in case of disaster, (Refer to (2) of the explanations given in the text.)</p>	<p>Act: Article 6, Article 7, Article 7-2, Section 1 and 2 of Article 12, Article 15, Section 1-8 of Article 18.</p> <p>Procedural Rules Act: Article 19, Articles 21-23, Article 26, Article 31, Article 33, Section 2 of Article 34, Article 35, Article 36 (Act: only those parts relating to Articles 19, 21, 26, 31, and 33, and Sections 2 and 3 of Article 34), and Article 37, Article 39, Article 40.</p> <p>Unit Rules Regulation: Article 22, Articles 28-30, Article 37, Article 39-2, Articles 41-43, Article 46, Article 48, Article 49, Article 67, Article 70, Clause 8 of Chapter 3, Articles 112 and 114, Chapter 5, * 2 of Chapter 5, and Articles 129-13-2 and 129-13-3.</p> <p>Group Rules Act: Chapter 3 (Article 63 will apply to the buildings within the fire prevention and the semi fire prevention zones, and which have a total floor space greater than 50 square meters.)</p> <p>Procedural Rules Act: Section 1 and 2 of Article 12.</p> <p>Unit Rules Act: Articles 21-27, Article 31, Section 2 of Article 34, Section 1 of Article 35, and Article 35-3. Regulation: Article 22, Articles 28-30, Article 37, Article 39-2, Article 46, Article 49, Article 67, Article 70, Clause 8 of Chapter 3, Article 112, Article 114, Chapter 5-2, Article 129-13-2, Article 129-13-3.</p> <p>Group Rules Act: Clause 1-5 of Chapter 3.</p>
<p>Section 4 of Article 85 Temporary buildings, such as those in amusement parks and those built for use during the construction of a permanent building. (Refer to (4) of the explanation given in the text.)</p>	<p>Act: Clause 1-5 of Chapter 3.</p>

* TRANSLATOR'S NOTE: There is a typographical error at this point. A word, which we believe is "clause", is omitted.

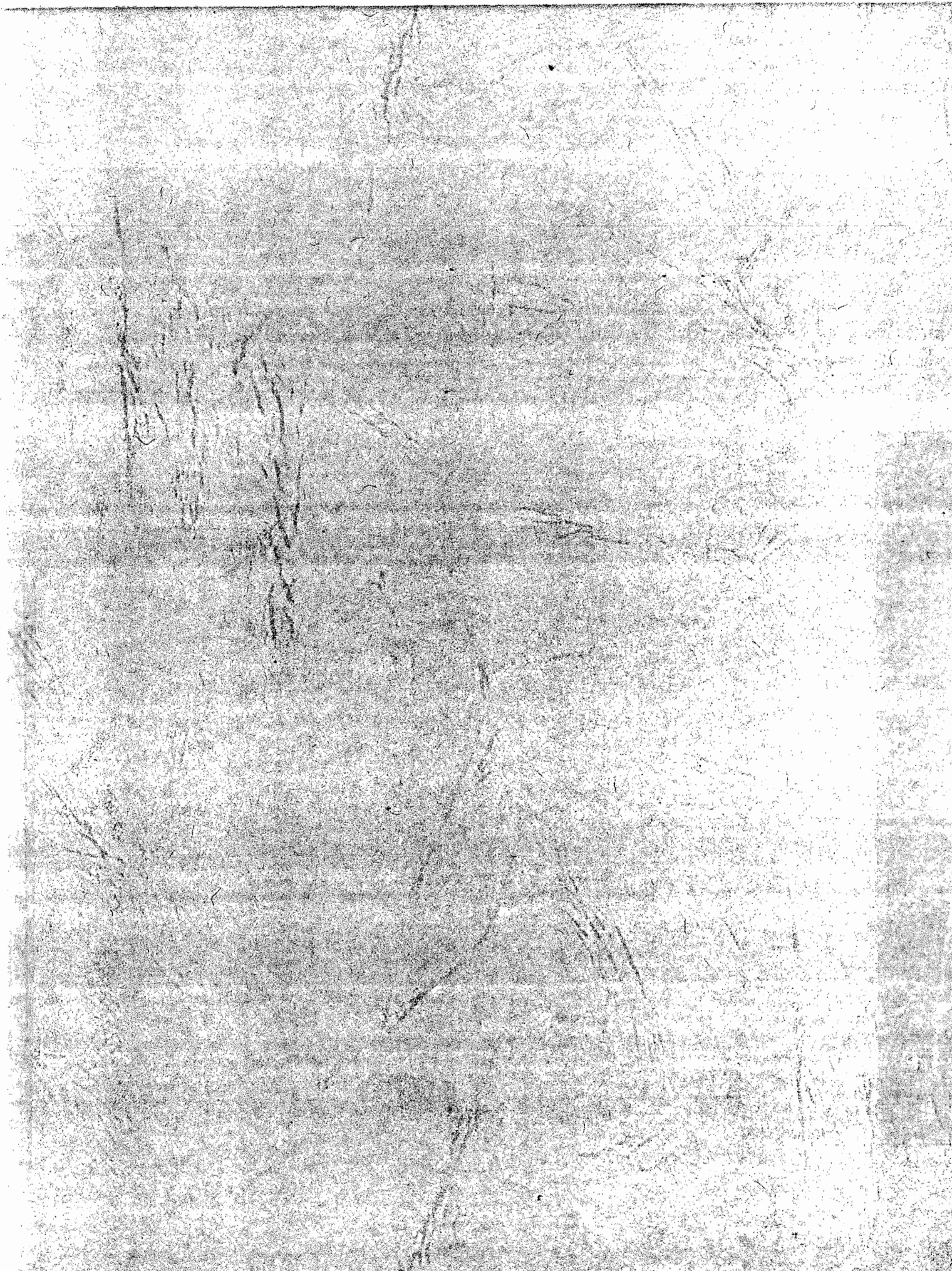

building is completed.

4. Permission from the Designated Administrative Agency for temporary usage is required for other temporary buildings such as those in amusement parks and exhibition halls (duration of up to a year) and temporary stores for use while the permanent store is in construction (duration is limited to the construction period). Only regulations dealing with structural strength and fire prevention will apply to these buildings (section 4 of Article 85 of the Act).